

DINSTAR



G100 Series IP Phone User Manual

Preface

Welcome

Thanks for choosing the G100 Series IP phone! We hope you will make full use of this rich-feature IP phone; contact us if you need any technical support: 0755-61919966.

About This Manual

This manual provides information about the introduction of the IP phone and about how to install, configure, or use it. Please read this document carefully before installing the G100 Series IP phone.

Intended Audience

This manual is aimed primarily at the following people:

- Users
- Engineers who install, configure, and maintain the G100 Series IP phone.

Revision Record

Document Name	G100 Series IP Phone User Manual
Version	V1.0
Firmware Version	2.100.11.13.0
Author	Technical Department
Date	2026/3/24
Description	The new released product

Conventions

The phone or device mentioned in this document refers to the G100 Series IP phone. “Note” marked in the document is what users need to pay attention to.

Contents

Preface.....	I
Welcome	I
About This Manual	I
Intended Audience	I
Revision Record.....	I
Conventions	I
1 Overview	1
1.1 Introduction.....	1
1.2 Features.....	1
1.3 Hardware Introduction	5
1.3.1 Front View and Keypad Description.....	5
1.3.2 Rear View and Panel Descriptions.....	6
1.3.3 Screen and Icons.....	6
2 Installation	8
2.1 Inspection.....	8
2.2 Installation	8
3 Functions.....	11
3.1 Make a Call	11
3.1.1 Call Modes.....	11
3.1.2 Methods to Make Calls.....	11
3.2 Answer the Call.....	13
3.3 Silence or Reject the Call.....	14
3.4 End Calls.....	14
3.5 Mute.....	15
3.6 Hold and Resume Call	15
3.7 DND.....	15
3.8 Call Waiting	17
3.9 Call Completion.....	17
3.10 Call Forward	18
3.11 Call Transfer.....	19
3.11.1 Blind Transfer	20
3.11.2 Semi-Attended Transfer:	20
3.11.3 Attended Transfer.....	20
3.12 Conference Calls.....	20
3.12.1 Local Conference.....	21
3.12.2 Network Conference.....	22

3.13 Call Park	22
3.13.1 Call Park and Call Retrieve	23
3.14 Pickup	23
3.14.1 Directed Pickup	24
3.14.2 Group Pickup	24
3.15 Speed Dial	24
3.16 Auto Redial	25
3.17 Intercom	25
3.18 Hot Desking	25
3.19 XML Browser	26
3.20 Call Recording	26
3.21 Keypad Lock	27
3.22 BLF	27
3.22.1 Set a BLF Key	28
3.22.2 Pick Up a Call by BLF Key	28
3.22.3 Blind Transfer a Call by BLF Key	28
3.22.4 Attended Transfer a Call by BLF Key	28
3.23 BLF List	29
3.24 Automatic Call Distribution (ACD)	29
3.25 Call Return	30
3.26 Messages	30
3.26.1 Text Message	30
3.26.2 Voice Message	31
3.27 Edit the number before calling	32
3.28 Echo Testing	33
3.28.1 Handfree echo	33
3.28.2 Handset echo	34
3.28.3 Headset echo	34
4 Settings	36
4.1 Basic settings	36
4.1.1 Language	36
4.1.2 Date & Time	36
4.1.3 Ring Tones	38
4.1.4 Phone Volume	38
4.1.5 Backlight	38
4.1.6 Reboot	39
4.2 Phone Book	39
4.2.1 Local Phone Book	39
4.2.2 Blacklists	40

4.2.3 Remote Phone Book	41
4.3 History Management.....	41
4.4 Customizing your phone	42
4.4.1 Programmable Keys.....	42
4.4.2 SIP Account Management.....	42
4.5 Basic Network Settings.....	43
4.5.1 LAN Mode.....	43
4.5.2 DHCP Mode	43
4.5.3 Static IP Mode	43
4.5.4 PPPoE Mode.....	43
4.5.5 Configure VLAN	44
4.6 Web Server	44
4.7 Reset to Factory	45
4.8 Password Setting.....	45
4.9 Auto Provision	45
5 Web Interface	46
5.1 Login & Logout	46
5.2 Status.....	47
5.2.1 Status->Basic	47
5.2.2 Status->Wi-Fi Status (only for Wi-Fi IP Phone).....	48
5.3 Account	49
5.3.1 Account->Basic	49
5.3.2 Account->SIP Param.....	52
5.3.3 Account->Advanced	56
5.3.4 Account-> Codecs.....	58
5.4 Network	59
5.4.1 Network->Basic.....	59
5.4.2 Network->Advanced.....	60
5.4.3 Network ->Wi-Fi (only for Wi-Fi IP Phone)	61
5.4.4 Network ->TR069.....	62
5.4.5 Network ->SNMP	63
5.4.6 Network ->NMS	64
5.4.7 Network ->VLAN&QoS	65
5.4.8 Network ->802.1X.....	66
5.4.9 Network ->Diagnosis.....	67
5.5 Phone	68
5.5.1 Phone->Basic.....	68
5.5.2 Phone->Time&Date.....	69
5.5.3 Phone-> Call Feature	71

5.5.4 Phone->Voice.....	74
5.5.5 Phone->Key.....	76
5.5.6 Phone->Ringtones.....	77
5.5.7 Phone->Tones.....	78
5.5.8 Phone ->Dial Plan.....	79
5.5.9 Phone->Action URL.....	80
5.5.10 Phone ->Multicast.....	82
5.5.11 Phone->Forward & DND.....	83
5.5.12 Phone->Intercom.....	86
5.5.13 Phone->ACD.....	86
5.5.14 Phone->Power LED.....	87
5.6 Phone Book.....	88
5.6.1 Phone Book -> Local Book.....	88
5.6.2 Phone Book -> Remote Book.....	89
5.6.3 Phone Book -> Call History.....	90
5.6.4 Phone Book -> LDAP.....	91
5.6.5 Phone Book -> Broadsoft.....	92
5.6.6 Phone Book -> Enterprise Directory.....	93
5.7 Maintain.....	94
5.7.1 Maintain->Upgrade.....	94
5.7.2 Maintain->Auto Provision.....	94
5.7.3 Maintain->System Log.....	96
5.7.4 Maintain->PCAP.....	96
5.7.5 Maintain->Configuration.....	97
5.7.6 Maintain->PnP.....	97
5.7.7 Maintain->Custom Language.....	98
5.8 Security.....	98
5.8.1 Security->Basic.....	98
5.8.2 Security->Advanced.....	99
5.8.3 Security->Firewall.....	100
6 Troubleshooting.....	102
7 Appendix.....	103
7.1 Abbreviations.....	103
7.2 Time Zones.....	104

1 Overview

1.1 Introduction

The dinstar G100 Series are entry-level IP phones which provides two SIP accounts with some models supporting 4G/Wi-Fi access. It can handle calls in a variety of environments including offices phone system, call centers, reception areas and other scenarios. With HD voice and other telephony features, the IP Phone offers a cost-effective solution to fulfill important VoIP telephony requirements.

Furthermore, the installation and configuration process are straightforward, and the web interface is intuitive and user-friendly. The integrated PoE and 10/100/1000 Mbps network ports make it ideal for extended network use.

This document applies to the G100/G100P, G100-T, G100-W and G100-V series IP phones.

Note: Some models may not support certain individual parameter settings, refer to the specific model's configuration or ignore explanations in this document that do not apply to a given model.

1.2 Features

➤ Key Feature

- HD Voice
- 2 SIP Accounts
- 2 Line keys
- 5-way Conference
- 132x64 pixel Graphical LCD with Backlight
- Magnetic Handle
- Dual-port 10/100/1000Mbps Ethernet
- Support LTE TDD, LTE FDD (For 4G phones only)
- Built-in 2.4GHz&5GHz Wi-Fi (For Wi-Fi phones only)
- Support EHS wireless headset (Plantronics, Jabra, Sennheiser)
- Stand with 2 adjustable angles
- Support Geofencing/Base Station Locking (For G100-V phone only)
- Supports dual SIMs, single standby (For G100-V phone only)
- Full Compatible with 3CX, Asterisk, Yeastar, Xorcom, VoIP.ms, Broadsoft, FreeSWITCH Platform etc.

➤ **Call Features**

- 2 SIP Accounts
- Call waiting / Call Forward/Call Transfer (Blind/attended transfer)
- Call hold / Call mute / DND mode
- Speed Dialing / Hotline
- Redial / Call Return
- Auto-redial / Auto-answer
- Dail Plan
- 5-way Conference
- Peer Dialing

➤ **Audio features**

- HD Voice
- Wideband Audio Codec: G.722, OPUS-WB
- Narrowband Audio Codec: PCMA, PCMU, G.729A/B, G.723.1, G.726, AMR, OPUS, iLBC
- Echo Cancellation/Dynamic Jitter
- Voice Activity Detection (VAD)
- Comfort Noise Generation (CNG)
- Full-duplex Speaker

➤ **Protocols & Standards**

- SIP v1 (RFC2543), v2 (RFC3261)
- SIP over TLS, SRTP
- TCP/IP/UDP
- RTP/RTCP, RFC2198, RFC1889
- HTTP/HTTPS/FTP/TFTP
- ARP/RARP/ICMP/NTP/DHCP
- DNS SRV/ A Query/NATPR Query
- STUN, Session Timer (RFC4028)
- DTMF: In-Band, RFC2833, SIP INFO
- LLDP
- 802.1Q VLAN, 802.1X
- OpenVPN

➤ **Phone Features**

- Adjustable Voice Volume
- Selectable Ring Tones
- XML Browser
- Action URL/URI

- Programmable DSS keys
 - Keyboard Lock
 - Phonebook: 1000 Groups
 - Blacklist: 100 Groups
 - Call History: 100 Logs
 - Support 5 Remote Phonebook URLs
 - LDAP
 - Support Multiple Languages
 - Built-in Wi-Fi (For Wi-Fi phones only):
2.4GHz, 802.11 b/g/n/ax
5GHz, 802.11 a/n/ac/ax
 - Wi-Fi Encryption: WPA/WPA2-PSK/WPA3 (For Wi-Fi phones only)
 - Support EHS wireless headset (Plantronics, Jabra, Sennheiser)
- **IP-PBX Features**
- SMS, Voicemail, MWI
 - Music On-hold, Intercom, Multicast
 - BLF (Busy Lamp Field)
 - Call Pickup, Call Pickup in Group
 - Anonymous Call
 - Anonymous Call Rejection
- **LTE Frequency Bands**
- 4G phones with several options:**
- Type EUX
FDD: B1/B3/B7/B8/B20/B28A
TDD: B38/B40/B41
 - Type AFX
FDD: B2/B4/B5/B12/B13/B14/B66/B71
 - Type AUX
FDD: B1/ B2/B3/B4/B5/B7/B8/B28
TDD: B40
 - Type CN
FDD: B1/B3/B5/B8
TDD: B34/B38/B39/B40/B41
- **Management**
- Auto provisioning: FTP/TFTP/HTTP/HTTPS/PnP
 - Configuration via HTTP/HTTPS web

- SNMP, TR069
- Network capture
- NTP/Daylight saving time
- Firmware upgrade via web
- Syslog
- Configuration backup/restore
- Equipment Management System (NMS)

➤ **Physical Features**

- 132x64 pixel graphic LCD with backlight
- Dual-angle foot stand: 40° and 45°
- Dimensions(approx.):
180*183*34mm (WxHxD) without foot stand
- Input voltage: 5Vdc
- Power supply: 5Vdc power adapter or PoE
- Handset: 4P4C, RJ9
- Headset: 4P4C, RJ9
- Environmental:
Operation temperature: 0~45°C
Storage Temperature: -10°C ~ 60°C
Humidity: 10% to 95% (non-condensing)
- Wall Mountable

1.3 Hardware Introduction

1.3.1 Front View and Keypad Description

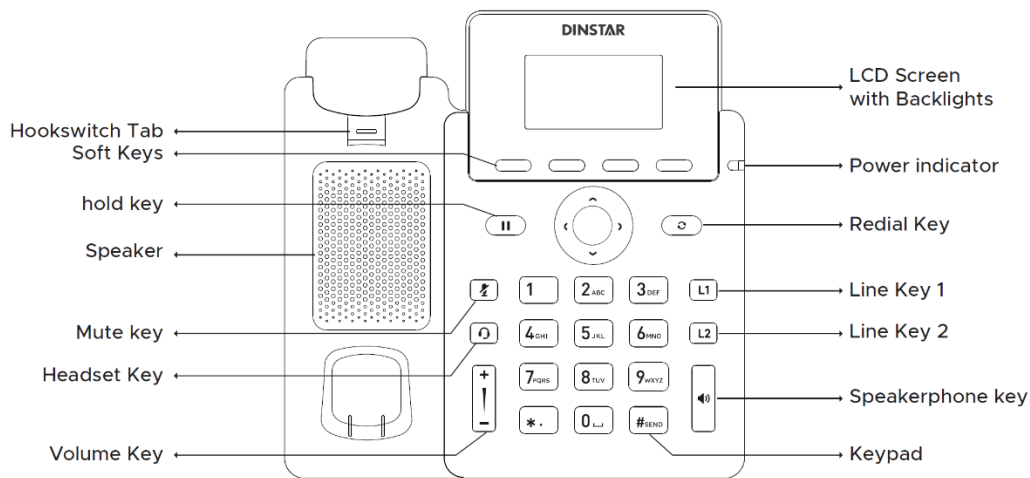

Name	Description
LCD Screen	Shows information about calls, messages, soft keys, time, date, etc.
Power LED Indicator	The power indicator indicates the call, message and system status: Solid blue: The phone is idle. Fast-flashing blue: The phone is ringing. Slow-flashing blue: The phone receives a message.
Cancel/Reject Key	Cancel the current actions or used as the return key.
Line Keys	When used as a programmable key or activated account, multiple functions can be configured.
Soft Keys	Used to complete the operations about the soft key labels which are displayed on the LCD screen. The labels include: History, Favorites, Redial, Call Return, Hot Desking, XML Browser, DND, Menu, MSG, Status, Book, FWD, Pickup, Intercom, Speed Dial and so on.
Navigation Keys	Assists you in selecting an item that you want to process under the menu by pressing the Up, Down, Right or Left key. When two SIM cards are inserted, you can manually switch SIM cards by pressing the left or right key.
Hold Key	Press this key during an active call, and you can place a call on hold.
Mute Key	Toggles the microphone on or off.
Speakerphone Key	Press this key to activate the speakerphone mode, and you can make the call hand-free.
Keypad	Provide digits, letters and special characters in context-sensitive application.
Volume -/+	Turn down or turn up the volume by pressing the “-” key or the “+” key.

Name	Description
Headset Key	Use the headset key to activate headset mode.
Speaker	Provides hands-free (speakerphone) audio output.
Hookswitch Tab	Secures the handset in the handset cradle when the IP phone is mounted vertically.
Magnetic Hookswitch	<ul style="list-style-type: none"> Lift the handset from the cradle to take the line off-hook. Replace the handset to the cradle to take the line on-hook.

1.3.2 Rear View and Panel Descriptions

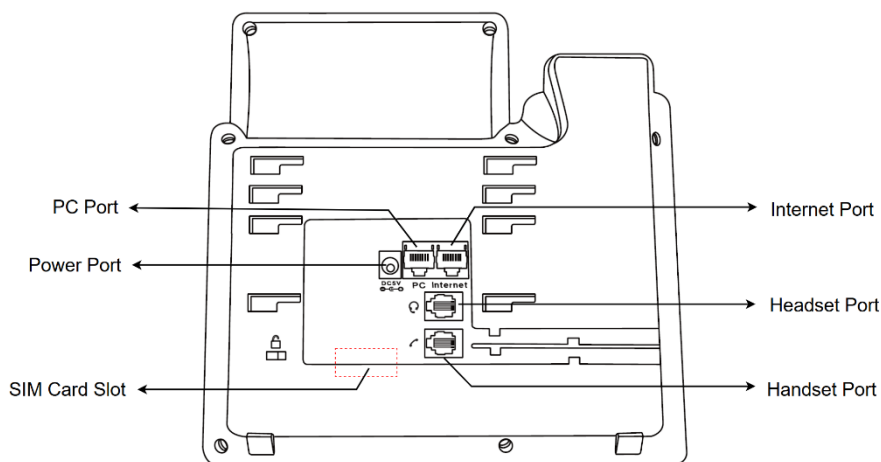

Name	Description
Power Port	Connect to power adapter (Input: 5V DC 1A)
Internet Port	Connect to Network (10/100M or 10/100/1000M)
Handset Port	Connect to handset (Port type: RJ-9 connector)
Headset Port	Connect to headset (Port type: RJ-9 connector)
PC Port	Connect to PC
SIM Card Slot	Insert SIM Card (only for 4G Phones)

1.3.3 Screen and Icons

The idle screen consists of status bar, line keys, soft keys, etc., as shown in the figure below:

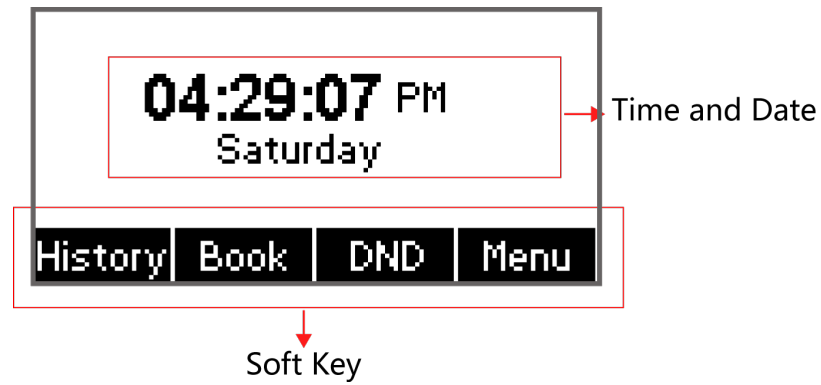

The icons displayed on the screen are as follow:

Icons	Description	Icons	Description
	Registered for account		muted
	Register failed		Headset mode
	Registering		Speakerphone mode
	Register Disabled		Handset mode
	Auto answer		New message
	Do Not Disturb		New voice message
	Forward		Miss calls
	Network Disconnection		Keypad Lock
	No SIM Card		Registered for SIM card

2 Installation

2.1 Inspection

Check the device and accessories with the device as per list of packing (See the table below).

Note: If the IP phone is powered by PoE, no power adapter will be provided.

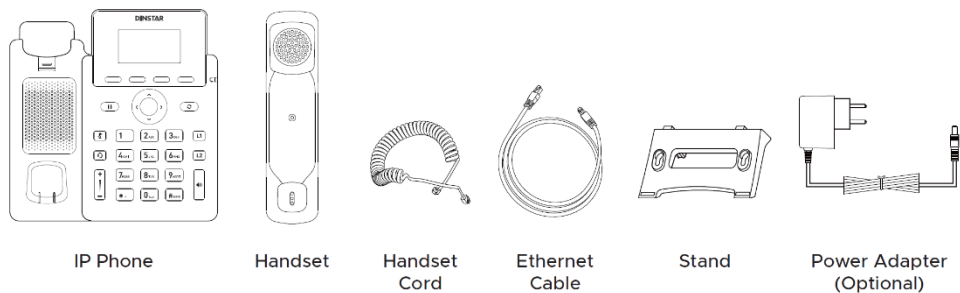

Name	Quantity
G100 Series IP Phone	1
Stand	1
Handset	1
Handset cord	1
Power Adapter (Optional)	1
Ethernet Cable	1

2.2 Installation

Step 1: Installing the stand

G100 Series IP phone supports two installation methods, as shown in the figure below. You can choose installation methods according to your habits and environment. Align the stand with the slot and push it to the top evenly, make sure it is fixed;

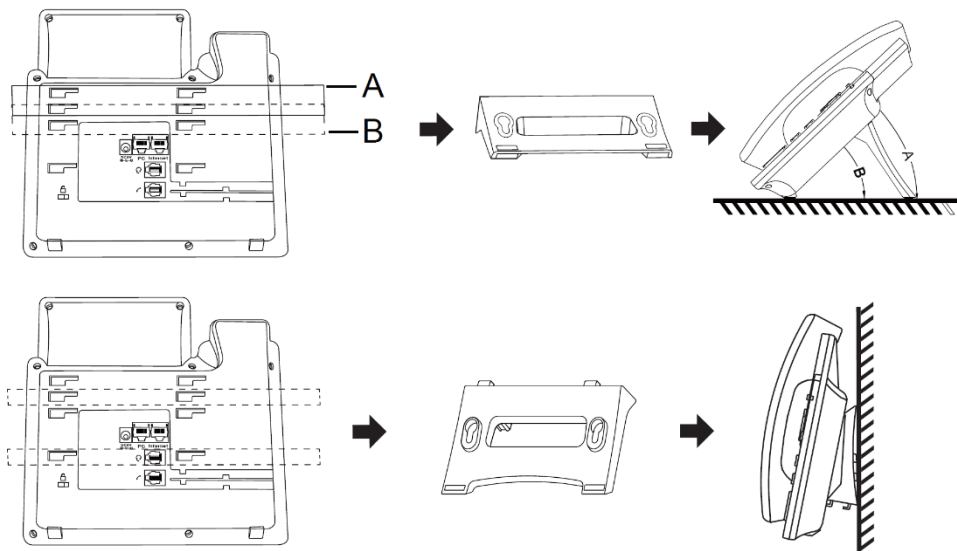

Step 2: Connecting power, Internet and handset

Connect the provided power adapter to the power port, and plug the other end of the adapter into an available power socket. After the power is connected, the LCD screen displays “Welcome, please wait...”;

- a) Connect wired network: Connect one end of the Ethernet cable to the Internet port on the back of the IP Phone, and the other end to the network jack.
- b) Connect 4G network: Insert the mobile carrier’s SIM card into the SIM slot; 4G model phones will automatically connect to the corresponding 4G network (4G models only).
- c) Connect Wi-Fi network: After powering on the device, go to **Settings**→**Basic Setting**→**Wi-Fi Network** to enable wireless connection, then select the desired SSID from the available networks, click Connect, and enter the Wi-Fi password to confirm (For Wi-Fi models only).

Connect one end of the Handset cord to the handle, and the other end to the Handset port, as shown in the figure below.

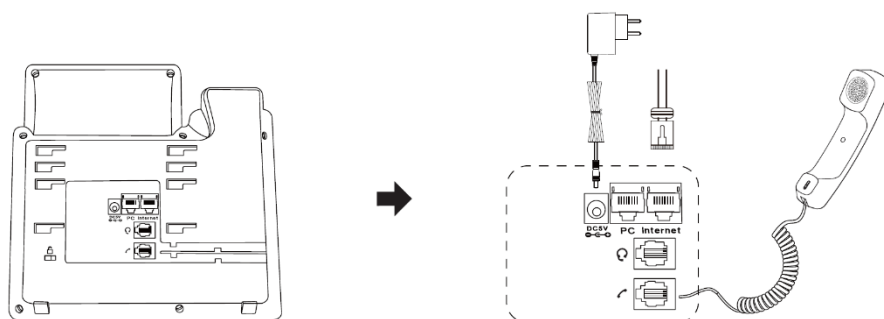

Note: Never use a power adapter other than the one provided with Dinstar.

Step 3-Getting Started





After the phone is connected to the power and network, the phone will automatically start up and the common functions of the phone can be used normally (see section 3 for more details). You can customize more functions through the Web platform or settings (see section 4 & 5 for more details).

3 Functions

3.1 Make a Call

3.1.1 Call Modes

You have the following three ways to make a call.

- 1) **Handset mode:** Pick up the handset, the  icon will be displayed in the upper left corner of the screen. And then enter a number or select a contact.
- 2) **Speakerphone mode:** Press the **Speakerphone Key** , the  icon will be displayed in the upper left corner of the screen. And then enter a number or select a contact.
- 3) **Headset mode:** Press the **Headset Key**  after the headset is connected to the headset port. The  icon will be displayed in the middle of the screen. And then enter a number or select a contact.



You can also enter a number first, and then choose the method you will use to speak to the other party.

3.1.2 Methods to Make Calls

Making a call from the Dialer

According to the number you input from the dial pad, the screen will display the previously saved contacts. You can select the contact you want to call from the list, or enter the number you want to call directly.

Procedure



- 1) Do one of the following:
 - Enter the number from the dial
 - Select the line key to be called
 - First take off the handle or press the **Speakerphone Key** ; and enter the number you want to call or select from the contact list;
- 2) Press soft key **Send** or select **Dial Key**  from keypad.

Note: You can set the dial key through *Menu>Function>Dial Key*.

Making multiple calls

During the call, you can keep the current call and then make other calls.



Procedure

- 1) Do one of the following:
 - Select a line key to keep the current call;
 - Press the **Hold Key**  to hold the current call;
- 2) Enter the number you want to call or select from the displayed contact list;
- 3) Press soft key **Send** or select **Dial Key**  from keypad.

Making a call with Speed Dial Key

You can use speed dial keys to call the number you dialed often or the number which it is hard to remembered. The steps for setting the quick dial key are as follows:



Procedure

- 1) Navigate to *Menu > Features > Programmable Keys*;
- 2) Select the **Line Keys**;
- 3) Pick a line key from the list;
- 4) Press the **up**  /  **down** navigation key or the **Switch** soft key in the type bar to select **Speed Dial**;
- 5) (Optional) Enter the name that will be displayed on the screen in the label bar;
- 6) Enter the number that will be set as the speed dial in the value field
- 7) In the account field, select the account that is set as a speed dial key and used for outgoing calls;
- 8) Select the **Save** soft key to complete the setting.

Calling back the last call

You can use the redial key to quickly dial the last call.



Procedure

- 1) Navigate to *Menu > Features > Programmable Keys*;
- 2) Select the **Line Keys**;
- 3) Pick a line key from the list;
- 4) Press the **left**  /  **right** navigation key or the **Switch** soft key in the type bar to select **Call Return**;
- 5) (Optional) Enter the name that will be displayed on the screen in the label bar;
- 6) Select the **Save** soft key to complete the setting.

Redial

The phone will save the record of calls. You can directly redial the number you have dialed.

Procedure



- 1) Press the **Redial Key**  and the dialed calls list will be displayed on the screen.
- 2) Press the **up**  /  **down** navigation key to select the number you want to redial.
- 3) Select **Dial** soft key.

Tips: pressing the Redial key  twice in succession will directly dial out the last called.

Making a call from the history list

You can call the number directly from the history list. The history record includes all dialed calls, received calls, missed calls, and forwarded calls.

Procedure

- 1) Select **History** soft key or navigate to *Menu > History*, all call records will be displayed on the screen;
- 2) Press the **up**  /  **down** navigation key to select the number you want to redial;
- 3) Select **Dial** soft key.

Making a call from the contact list

You can call directly from the contact list

Procedure

- 1) Select the **Book** soft key or navigate to *Menu > Book > Local Phone Book*;
- 2) Select the group or contact you want to call;
- 3) Select **Dial** soft key.



3.2 Answer the Call

Manually answer a call

The phone will ring when receiving an incoming call. You can answer the call manually.

Procedure

Do one of the following:

- Pick up the handset to answer;
- Press the Speakerphone Key  to answer;
- Press the Headset Key  to answer;
- Press the Answer soft key or press the line keys that is flashing green. In this case, the speakerphone mode will be activated to answer incoming calls.

Answering a new incoming call

You can answer a new incoming call while you are on a call. When there is a new incoming call, the phone emits a "beep" and the screen shows the incoming information, and the green light of the incoming line key flashes.

Procedure

After selecting the **Answer** soft key to answer the new call, the previous call is put on hold.

Auto answer

When the phone is idle, you can enable the speakerphone mode to automatically answer incoming calls.

Procedure

- 1) Navigate to *Menu* > *Settings* > *Advanced Settings* (password: *admin@123#*);
- 2) Select the account that you want to activate auto answer and click the **Enter** soft key;
- 3) In the auto answer bar, select **Enable** by the soft key **Switch**;
- 4) Select **Save**.

3.3 Silence or Reject the Call

You can ignore or reject the call when you receive an incoming call.

Silencing call

If you ignore the incoming call, the phone will no longer ring, but the incoming call information is still displayed on the phone screen.

Procedure

Select the **Mute** soft key or press the **Mute Key** .

Manually reject calls

When the phone receives an incoming call, you can reject it. The rejected call will be displayed in the history of received calls.

Procedure

Select the **Reject** soft key to reject the incoming call.

Using Do Not Disturb (DND) to reject all calls

If you don't want to be disturbed by incoming calls, you can use the Do Not Disturb function to automatically reject all incoming calls or all incoming calls from a specified account. For details, please refer to 3.7 Do Not Disturb > Enable Do Not Disturb in Default Mode.

Using the Do Not Disturb (DND) to reject all calls from a specified account

By default, the DND mode applies to all accounts. You can set the mode through the web system to enable the DND function of a specific account. For the specific configuration, please refer to 3.7 DND > Enable Do Not Disturb in Custom Mode.

3.4 End Calls

You can end the current call at any time.

Procedure

Do one of the following:



- If the phone works in handset mode, press the **Cancel** soft key or

- hang up the call;
- If the phone works in headset mode, press the **Cancel** soft key;
- If the phone works in speakerphone mode, press the **Speakerphone** key  or press the **Cancel** soft key.

3.5 Mute

When you enable the mute function during a call, the other party will not receive your voice message, but you can.



Procedure

- 1) Press the **Mute Key**  to enable the mute function, the other party will not hear you, but you can. At this time, the mute icon  is displayed on the LCD screen;
- 2) Press the **Mute Key**  again to disable the mute mode.

3.6 Hold and Resume Call

You can put a call on hold and resume the call at any time. The held party may hear the music sent from the PBX server while waiting.

Procedure

- 1) During the call, press the **Hold Key**  or select the soft key **Hold**. At this time, the screen will flash the hold icon and information;
- 2) Press the **Hold Key**  again or select **Resume** to resume the call.

Note:

When there are multiple calls, you can switch to a different line call by pressing the corresponding line.

3.7 DND

If you don't want to be disturbed by incoming calls, you can set the DND function. The DND feature is applicable to all accounts and can also be directed to a specific account. And we also provide you with a DND Timer Enable.

The DND setting depends on the phone mode: phone mode or custom mode (the default is phone mode). In the phone mode, the DND function will be enabled for all accounts of the phone; in the custom mode, the DND function can be set for a specific account. Both the modes need to be set on the web system.

DND function is enabled in default mode

Procedure

Do one of the following:

- Select the soft key **DND**, the screen will display the DND icon 

- in the middle of the screen;
- Navigate to **Menu > Features > DND Code**.
 - 1) Select to **Enter** soft key;
 - 2) Select the **Switch** soft key to enable the DND function;
 - 3) (Optional) Input the value in the area of “On” code and “Off” code;
 - 4) Select **Save**.

After the setting is complete, the screen will display the DND icon , which will not change when switching between different accounts to the current default account.

DND function is enabled in custom mode

1. Setting custom mode on the Web page

You can log in to the phone with the account User, Navigate to **Phone > Forward & DND**, as shown in the figure below. Select the phone mode on this page, and click **Submit** to save the configuration.



Sync Feature Code

Active	Disabled ▼
Mode	<input type="radio"/> Phone <input checked="" type="radio"/> Custom

2. Enabling DND for specific accounts

Procedure

- 1) Navigate to **Menu > Features > DND Code**;
- 2) Select an account;
- 3) Enable DND function;
- 4) (Optional) Input the value in the area of “On” code and “Off” code;
- 5) Select **Save**.

When you use the up and down navigation keys   to switch between different accounts as the default account, the account that has set the DND function will display the DND icon  on the screen.

DND timer enable

You can enable the DND timer according to your work and rest habits, and reject all calls during the period you set. There are three sets. The ranges of the three periods can overlap.

Log in to the phone with the account User, navigate to **Phone > Forwarding & DND**, set DND Timer to Enable, then set the period, and finally select Submit to save the configuration.

DND	
Account	Account 1
DND	Enabled
Return Code When DND	486 (Busy Here)
DND On Code	
DND Off Code	
DND Timer Enable	Enabled
DND Timer 1	0 Hour 0 Min - 23 Hour 59 Min
DND Timer 2	0 Hour 0 Min - 23 Hour 59 Min
DND Timer 3	0 Hour 0 Min - 23 Hour 59 Min

Disabling DND

When you need to answer a call, you can disable the DND function.

Procedure

- 1) Navigate to *Menu > Features > DND Code*;
- 2) Select a specified account or select all accounts;
- 3) Disable the DND function;
- 4) (Optional) Input the value in the area of "On" code and "Off" code.
- 5) Select Save.

After the setting is completed, the DND icon  will disappear from the screen.

3.8 Call Waiting

You can enable the call waiting function so that you can answer new calls during the call, otherwise, the new call will be automatically rejected and a busy tone will be displayed. You can enable the call waiting tone function at the same time. When you receive a new call during a call, The phone will emit a "beep" tone to indicate a new call.

Procedure

- 1) Navigate to *Menu > Features > Call Waiting*.
- 2) Select to **Enable** call waiting.
- 3) (Optional) Select to **Enable** tone.
- 4) Select **Save**.

3.9 Call Completion

When you fail to call out, you can use the call completion function to monitor the called party and re-establish the call when the called party is free.

Note:

Not all servers support the call completion. Please consult your system administrator for further information.

Procedure

- 1) Navigate to *Menu > Features > Call Completion*.
- 2) Enable call completion.

3) Choose **Save**.

When you initiate a call and the called party is busy and does not answer, the screen prompts you whether to wait for the called party, select OK to activate the call completion function.

When the called party is idle, the screen prompts you whether to initiate a call. Selecting OK will initiate the call again.

3.10 Call Forward

When you cannot handle an incoming call in a timely manner, you can forward the incoming call to an available number.

Setting the type of forwarding calls:

Always Forward: All incoming calls will be automatically forwarded to the pre-configured number.

Busy Forward: When the phone is busy, the incoming call will be forwarded to the pre-configured number.

No Answer Forward: When the phone does not answer within the set time, the incoming call will be forwarded to the pre-configured number.

Forwarding all calls

After enabling call forwarding, you can forward all incoming calls on the phone. The activation method is as follows:

Note:

Some servers need to set the enable code and the disable code for call forwarding. Please consult your system administrator for further information.

Procedure

- 1) Navigate to *Menu > Features > Call Forward*;
- 2) Select a call forwarding type, and then select **Enable** in the active bar;
- 3) Enter the number to be forwarded in the forward to area;
- 4) If you choose no answer forward, enter the time in the timeout bar;
- 5) (Optional) Input the value in the area of “On” code and “Off” code;
- 6) Select **Save**.

After configuring call forward, the call forward icon  is displayed on the screen.

Forwarding the call to the designated account

By default, enabling call forwarding applies to all accounts. You can enable call forwarding for specific account by setting the phone mode.

① Setting the custom mode on the Web page

You can log in to the Web with the account user, navigate to *Phone > Forwarding & DND*, set the phone mode to Custom, and select Submit to save the configuration.

Sync Feature Code	
Active	Disabled <input type="button" value="v"/>
Mode	<input type="radio"/> Phone <input checked="" type="radio"/> Custom

② Setting call forward for designated account on the phone

Procedure

- 1) Navigate to *Menu > Features > Call Forward*;
- 2) Select a call forwarding type, and then select **Enable** in the active bar;
- 3) Select an account;
- 4) Enter the number to be forwarded in the forward to area;
- 5) If you choose no answer forward, enter the time in the timeout bar;
- 6) (Optional) Input the value in the area of On Code and Off Code;
- 7) Select **Save**.

After configuring call forward, the call forward icon  is displayed on the screen.

Disabling call forward

When you no longer need to forward incoming calls, you can choose to disable the call forward.

Procedure

- 1) Navigate to *Menu > Features > Call Forward*;
- 2) (Optional) If the call forward works in a custom mode, you need to select an account;
- 3) Select the call forwarding type, and then select **Disable** in the active bar;
- 4) Select **Save**.

Forwarding a call by hand

You can also select the soft key Forward to forward the call to someone else when the call is ringing.

Using the soft key Forward

Procedure

- 1) When the phone is ringing, select the soft key **Forward**;
- 2) Enter the number to be forwarded or select the number from the book;
- 3) Press the **OK** soft key.

Incoming calls forwarded will be marked as forwarded calls in the call history.

3.11 Call Transfer

You can transfer calls to other during a call. There are the following three transfer methods:

Blind transfer: Transfer the call to a third party directly without prior notice;

Semi-Attended Transfer: When you hear the back tone, transfer the call to a third party;

Attended Transfer: After the third party answers the call and consults, the call is transferred to the third party.

3.11.1 Blind Transfer

You can transfer directly without notifying the third party, as follows:

Procedure

- 1) Press the soft key **Trans** during the call;
- 2) Enter the number to be transferred or select a number from the book;
- 3) Press the soft key **Trans** again.

Note:

If the phone works in handle mode, you can directly put the handle back to complete the transfer.

3.11.2 Semi-Attended Transfer:

You can transfer the call to the third party after hearing the back tone.

Procedure

- 1) Press the soft key **Trans** during the call;
- 2) Enter the number to be transferred or select a number from the book;
- 3) Press **Send** soft key;
- 4) After hearing the ring back, press the soft key **Trans** again to complete the semi-attended transfer.

Note:

You can directly put the handle back to complete the transfer in the handset mode.

3.11.3 Attended Transfer

You can transfer the call to the third party after hearing the back tone.

Procedure

- 1) Press the soft key **Trans** during the call;
- 2) Enter the number to be transferred or select a number from the book;
- 3) Press **Send** soft key;
- 4) After the third-party answers and consults, press the soft key **Trans** again to complete the attended transfer.

Note:

You can directly put the handle back to complete the transfer in the handset mode.

3.12 Conference Calls

The phone supports the creation of three-party local conferences and multi-party network conferences.

During the conference, please follow the suggestions below:

- If you are attending the conference in public, please use the handset or headset mode.
- Please switch to mute mode when you are not speaking in the meeting
- Avoid knocking near the microphone or close to electronic equipment.
- Please speak at a normal volume.
- Adjust the microphone direction appropriately when there are harsh sounds in speech.

3.12.1 Local Conference

You can establish a five-party (including local) conference with your contacts.

Creating a local meeting



Procedure

- 1) Press the **New** soft key to make a new call to a third party during an active call.
- 2) Press the **Conf** soft key to start a three-way conference after the third party has answered the call.
- 3) Press the **Conf** soft key, enter the number, then press the **Send** soft key to call the fourth party.
- 4) Press the **Conf** soft key to start a four-way conference after the fourth party has answered the call.
- 5) Repeat step 3 to step 4 **again** to start the five-way conference.
- 6) When the call conference ends, press the **End** soft key to disconnect all parties.

Holding or resuming a conference call

When you hold a conference call, the participants in the conference cannot hear the other party until you resume the conference call.



Procedure

- 1) Press the **HOLD** key  or press the soft key **Hold** to keep the current conference call;
- 2) Press the **HOLD** key  again or press the soft key **Resume** to resume the current conference call.

Muting or unmuting a conference call

The microphone is turned off when you mute a conference call, and other parties cannot hear yours.

Procedure

- 1) Press the **MUTE** key  to turn on mute during the conference;
- 2) Press the **MUTE** key  again to unmute.

Splitting a conference call

You can split the current conference call into independent calls. After splitting, the conference call ends, other participants are on hold.

Procedure

In the conference, select the soft key **Separate** to end the conference and split the participants into two calls.

Ending conference call

During the meeting, you can manually end the meeting at any time. If you end the conference call, the conference of other participants will also end.

Procedure

Select the soft key Cancel or hang up the handset when using the handset or press the Speakerphone key  in the Speakerphone mode to end the conference call.

3.12.2 Network Conference

If your administrator has set up the network conference function for your phone, you can create a multi-party network conference locally.

Create a network conference

Procedure

- 1) Call the first party;
- 2) After the first party answers, press the soft key **New** to start creating a new call;
- 3) Enter the number of the second party or select the number from the book and call out. The call of the first party is on hold now;
- 4) After the second party answers, press the soft key **Conference** to start a three-party conference;
- 5) Select the soft key Conference again to invite other members. The conference call is on hold now;
- 6) Enter the invited number or select the number from the book and call out;
- 7) After the new member answers, select the Conference again and add the new member;
- 8) Repeat steps 5-7 to add more members.

Note:

The method of creating a multi-party conference may vary depending on the server. Please consult your administrator for more information.

3.13 Call Park

You can use the call park function to maintain the current conversation, and then resume the call on another. According to different parking modes, it can be divided into code mode and call transfer mode.

Note:

Not every server supports call park and the support methods are also different. Please contact your administrator to confirm whether this feature is available.

3.13.1 Call Park and Call Retrieve

Parking a call in the park code mode

You can use this feature to park a call, and then retrieve the call either from your phone or another phone. After you park a call, the call is placed on hold, you can continue the conversation after retrieving it.

Procedure

- 1) Make a call;
- 2) During the call, the parked party enters the park code on the keyboard and sends it;
- 3) Hang up the call after listening to the park number. At this time, the other party is on hold;
- 4) On another phone, enter a park code or an extension number and send;
- 5) Resume the parked call on the new phone.

Note:

The above steps will be slightly different according to the different server implementation. If you need this feature, please confirm with your administrator.

Parking a call in the transfer mode

You can park the call at the location specified by the server by transferring the call.

Procedure

- 1) Navigate to *Menu > Features > Programmable Keys > Line Keys/ Soft Keys/ Function Keys*
- 2) (Take line keys as an example) Select a line key and then select **Enter**, select **Call Park** in the type bar;
- 3) (Optional) Enter the information displayed on the screen in the label bar;
- 4) Enter the park code + extension number in the value area;
- 5) Select **Save**.

3.14 Pickup

You can use the pickup feature to answer calls from others. There are following two modes:

Directed Pickup: Answer incoming calls from designated number.

Group Pickup: Pickup calls from any member in the same group. Group pickup needs to set up group members in advance.

3.14.1 Directed Pickup

You can answer incoming calls from a designated number.

Procedure

- 1) Navigate to *Menu> Features> Programmable Keys> Line Keys/ Soft Keys/ Function Keys* and select the soft key **Enter**;
- 2) (Take the line keys as an example) Select a line key and then select **Enter**, and select **Pickup** in the type bar;
- 3) (Optional) Enter the information displayed on the screen in the label bar;
- 4) Enter the pickup code in the value area and the account to be picked
- 5) Select **Save**.

When the designated number receives an incoming call, press the pickup key to allow the user's incoming call to be answered on your phone.

3.14.2 Group Pickup

You can answer an incoming call in the same group. If the group receives multiple incoming calls, it will answer the first by default.

Procedure

- 1) Navigate to *Menu> Features> Programmable Keys> Line Keys/ Soft Keys/ Function Keys* and select the soft key **Enter**;
- 2) (Take the line keys as an example) Select a line key and then select **Enter**, and select **Group Pickup** in the type bar;
- 3) (Optional) Enter the information displayed on the screen in the label bar;
- 4) Enter the group pickup code in the value bar;
- 5) Select **Save**.

When there is an incoming call in the group, press the group pickup key to make the incoming call in the group be answered on your phone.

3.15 Speed Dial

You can use the speed dial to quickly dial the specified number.

Procedure

- 1) Navigate to *Menu> Features> Programmable Keys> Line Keys / Soft Keys / Function Keys*;
- 2) (Take the line keys as an example) Select a line key and then select **Enter**, and select **Speed Dial** in the type bar;
- 3) (Optional) Enter the information displayed on the screen in the label bar;
- 4) Enter the number in the value area;
- 5) The account bar is to select a account to make a call;
- 6) Select **Save**.

Press the speed dial key when the phone is idle, and the selected account will automatically dial the preset number.

3.16 Auto Redial

You can use the automatic redial feature when the called party does not answer.

Note: Not all servers support the auto redial feature. Please consult your administrator for further information.

Procedure

- 1) Navigate to *Menu> Features> Auto Redial*;
- 2) Select enable in the active bar; fill in the time in the interval area; fill in the number of redial in the times bar;
- 3) Select **Save**.



After the phone call fails, an automatic redial countdown prompt will appear on the screen. You can press the **OK** soft key to redial or wait for the countdown to finish.

3.17 Intercom

You can make an intercom call to a contact. When receiving an intercom call, the phone will trigger an alert tone and automatically answer it in Speakerphone mode. The intercom feature is mainly used as the configuration of the receiver.

Procedure

- 1) Navigate to *Menu> Features> Intercom*;
- 2) Select **Enable** in the active bar;
- 3) (Optional) Select **Enable** in the mute bar;
- 4) Select **Save**.

If the intercom mute is enabled on the phone, that is, the automatically answered intercom call is in the mute, the mute icon  is displayed on the screen. You must press the Mute key  to cancel.

When intercom supported by the server, you need to dial the code of the intercom feature + the extension number of the other party to initiate an intercom call. Take a 3CX server as an example: dial *998100, where *998 is the intercom code, and 100 is the extension number. For the codes of the intercom feature of other servers, please refer to the configuration guide documents of the servers.

3.18 Hot Desking

You can press the Hot Desking key to clear the registration information of all accounts on the phone when the phone is idle. Then register the account you want to. Through this function, more users can share this phone at different periods. Especially suitable for some public places.

Note: Not all servers support Hot Desking, please consult your administrator for further information.

Procedure

- 1) Navigate to *Menu> Features> Programmable Keys> Line Keys / Soft Keys / Function Keys*;

- 2) (Take the line keys as an example) Select a line key and then select **Enter**, and select **Hot Desking** in the type bar;
- 3) (Optional) Enter the information displayed on the screen in the label bar;
- 4) Select **Save**.

When you press the Hot Desking key, the phone screen will show "Whether to clear all account configurations", select Clear to enter the account configuration. For further information, please refer to *Menu > Settings > Advanced Settings > Account*.

3.19 XML Browser

The XML browser allows users to deploy custom services on the server. Users can quickly access it using the XML browser key. This feature requires pre-configuration of custom services on the server, such as news, weather reports, and inventory information. The information will be received from the server and displayed on the screen, and all information will be transmitted in the form of XML.

Procedure

- 1) Navigate to *Menu > Features > Programmable Keys > Line Keys / Soft Keys / Function Keys*;
- 2) (Take the line keys as an example) Select a line key and then select **Enter**, and select **XML browser** in the type bar;
- 3) (Optional) Enter the information displayed on the screen in the label bar;
- 4) Enter the source path of the XML file in the value field;
- 5) Select **Save**.

When the phone is idle, press the XML browser key to access the XML browser specified.

3.20 Call Recording

The device sends a SIP INFO message with the "Record: on/off" header to trigger the server to record the call. The call recording will be saved on a server that supports the recording feature.

Note:

- 1). Not all servers support the call recording feature, please consult your administrator for further information;
- 2). Before recording calls, especially those involving analog telephone, you must understand all the rules and restrictions governing call recording in your country;
- 3). Similarly, before recording, inform all the callers that you are recording and obtain their consent.

Procedure

- 1) Navigate to *Menu > Features > Programmable Keys > Line Keys*;
- 2) Select **Record** in the type bar;
- 3) (Optional) Enter the information displayed on the screen in the label bar.

Press the record key during a call. If recording successfully, the LCD screen displays the icon . Press the record key again to stop recording. The recording icon on the screen disappears, and the record key LED stops flashing.

Manage recording: (Take the 3cx professional as an example) In the 3CX management console, the recording feature can help you search, manage, download and delete call recordings, and you can set the amount of recording and the time for automatic cleaning of call recordings.

3.21 Keypad Lock

You can use the keypad lock to ensure that your phone is not used by unauthorized users or avoid misuse. Once you lock the phone, anyone must enter the password to unlock the phone. You can choose the lock type: function key or all keys.

Keypad Lock	
Keypad Lock Type	Function Key <input type="button" value="v"/>
Keypad Unlock PIN (0~15)
Keypad Lock Timeout	0 (0~3600s)

Function keys: The function keys are locked. The line key, information key, soft key, navigation key, redial key, mute key, volume key, hold key, transfer key, speakerphone key, and headset key must be unlocked before they can be used.

All keys: All keys are locked. Until the PIN code prompt appears, the keyboard can be used.

The keypad lock function can only be configured through the web system.

Log in to the Web with the administrator account **Admin** (password: admin@123#) and navigate to **Phone> Keys> Keypad Lock**. Select the type of keypad to be locked, set a password in the Keypad Unlock PIN field, and the Keypad Lock Timeout is used to set the delay time when not operating.

When the keypad lock is enabled, the lock icon  will be displayed on the screen of the phone. Anyone needs to enter a password to unlock the keyboard. If the password is wrong, a prompt "Wrong password!" will be displayed.

3.22 BLF

The line can be monitored with the BLF key. Our phone supports three types of BLF: BLF/New Call; BLF/BXFER; BLF/AXFER.

BLF/New Call: This type is when the monitored line is idle, pressing the BLF key will make a new call to the monitored line.

BLF/BXFER: This type is to blindly transfer the current call to the monitored line when the line is idle.

BLF/AXFER: This type is to attended transfer the current call to the monitored line when the line is idle.

3.22.1 Set a BLF Key

The line key can be set to BLF key to monitor the line status.

Procedure

- 1) Navigate to *Menu> Features> Programmable Keys> Line Keys*;
- 2) Select the type of BLF in the type bar: BLF/New Call; BLF/BXFER; BLF/AXFER;
- 3) (Optional) Enter the information displayed on the screen in the label bar;
- 4) Enter the number to be monitored in the value bar.
- 5) (Optional) Select the account used for answering in the account bar;
- 6) (Optional) Enter the extension code in the extension bar.
- 7) Select Save.

After the BLF key is successfully configured, the server will notify the phone through a NOTIFY message after the status of the monitored line changes.

3.22.2 Pick Up a Call by BLF Key

If you configure the pickup account and pickup code of the BLF key, when the monitored line receives an incoming call, you can answer the incoming call on your phone, avoiding missing important calls.

Procedure

- 1) When the monitored line receives a call;
- 2) If BLF pickup is enabled, the display as follows;
- 3) Select the Pickup, the phone can pickup calls from the monitored line.

3.22.3 Blind Transfer a Call by BLF Key

If the type is BLF/BXFER for BLF key. Then the current call can be blind transfer when the monitored line is idle; and the blind transfer is not performed when the monitored line is not idle.

Procedure

- 1) Answer the incoming call;
- 2) If the phone needs to transfer the call to the monitored line, first check whether the monitored line is free;
- 3) Press the **BLF** key to blind transfer;
- 4) The monitored line can continue to talk.

3.22.4 Attended Transfer a Call by BLF Key

If the type is BLF/AXFER for BLF key. Then the current call can be attended transfer when the monitored line is idle; and the attended transfer is not performed when the monitored line is not idle.

Procedure

- 1) Answer the incoming call;

- 2) If the phone needs to transfer the call to the monitored line, first check whether the monitored line is free;
- 3) Press the **BLF** key to attended transfer;
- 4) The monitored line can continue to talk.

3.23 BLF List

You can set the line key to be a BLF list to monitor a group of users managed by the system administrator.

Procedure

- 1) Navigate to *Menu > Features > Programmable Keys > Line Keys*;
- 2) Select the **BLF** list in the type bar;
- 3) (Optional) Enter the information displayed on the screen in the label bar;
- 4) (Optional) Select the account used for pickup in the account bar;
- 5) Select Save.

When the monitored line receives the call, the phone can answer the call by pressing the BLF list

Note:

Not all servers support the BLF list. Please consult your system administrator for further information.

3.24 Automatic Call Distribution (ACD)

The ACD feature is often used in customer service centers, such as call centers. The ACD system can handle a large number of incoming calls. These calls do not need to pick up by agents, but they need to be handled or helped in proper way as soon as possible. The ACD feature is that the ACD system automatically allocates incoming calls to users who log in to the ACD system according to specific rules and strategies. ACD is disabled on the phone by default. You need to configure the line key to be an ACD so that the phone can log in to the ACD system and process the calls assigned by the system.

Procedure

- 1) Navigate to *Menu > Features > Programmable Keys > Line Keys*;
- 2) Select ACD in the type area;
- 3) (Optional) Enter the information displayed on the screen in the label bar;
- 4) Select the account used to log in to the ACD system in the account bar;
- 5) Select Save.

Configuration is completed, you can press the ACD key to log in to the ACD system to answer the call assigned to you.

3.25 Call Return

You can make the last call through the call return key.

Procedure

- 1) Navigate to *Menu > Features > Programmable Keys > Line Keys*;
- 2) Select **Call Return** in the type bar;
- 3) (Optional) Enter the information displayed on the screen in the label bar;
- 4) Select Save.

After the call return key is configured, press the call return key on the phone to automatically dial the last call.

3.26 Messages

The phone provides voice messages and text message communication methods. The text message supports sending new messages, receiving messages in the inbox, saving the sending messages in the outbox, and saving the editing information in the draft box. The messages that have been sent are saved. The voice message supports the configuration of different voice mailbox numbers for different accounts, the default is: *170*2#, and the voice message on the server can be obtained through subscription messages.

Note:

Not all servers support the voice message. Please consult your system administrator for further information.

3.26.1 Text Message

Text messages can be stored in the inbox, sent messages, outbox, and draft box, each of which can store 100 text messages. If the number of text messages exceeds, the phone will delete the farthest text message.

Reading a text message

You can read text messages through the inbox.

Procedure

- 1) Navigate to *Menu > Message > Text Message > Inbox*;
- 2) Select the text message you want to view, and then select Enter.

Note:

When the screen prompts you to receive a new text message, you can press the View soft key to read it.

Sending a text message

Procedure

- 1) Navigate to *Menu > Message > Text Message > New Message*;
- 2) Edit messages;
- 3) Select **Send** and fill in the number in the “To” bar;
- 4) Select **Send**.

Replying a text message

You can reply a text message after you have read it.

Procedure

- 1) Navigate to *Menu> Message > Text Message> Inbox*;
- 2) Select the text message you want to view, and then select Enter;
- 3) Select **Reply** soft key;
- 4) Edit the content of the text message;
- 5) Select **Send** and enter the number;
- 6) Select **Send** again.

Deleting a text message

You can delete the message you have read.

Procedure

- 1) Navigate to *Menu> Message> Text Message> Inbox (Sent Message, Outbox or Draft)*;
- 2) Select the message to be deleted;
- 3) (Optional) In step 2, you can select to **Enter**. When the message is confirmed to be deleted, select **Delete** to delete the message;
- 4) Select **Delete** to enter the delete option;
- 5) Select **Delete Single** or **Delete All**.

3.26.2 Voice Message

With the voice mail function, you can leave a voice message to someone or listen to your voice mail on your phone (not all servers support this function).

Setting the voice message code

Before viewing or listening to your voice message, you need to set the voice mail access code in advance (the code default: *170*2#).

Procedure

- 1) Navigate to *Menu> Message> Voice Message Setting*;
- 2) Select the account and set the voice code of each account;
- 3) Select **Save**.

voice message

When the called number is busy or not answering, you can leave a message to the contact.

Procedure

- 1) Leave a message for someone according to the voice prompt;
- 2) Follow the voice prompts to save the message or hang up the call.

Listening to voice message

You can view and listen to voice messages on the phone.

Procedure

- 1) Navigate to *Menu> Message > Voice Message> Voice Message view*;

- 2) The phone will list the message of all accounts;
- 3) Select an account with new messages;
- 4) Select **Connection**;
- 5) The phone will connect to the voice server by access code;
- 6) Follow the voice prompts to complete the message listening.

Note:

When the screen shows you to receive a new message, you can press the View soft key to listen to the new voice message.

3.27 Edit the number before calling

You can edit the number before calling.

Procedure

- 1) Navigate to *History->Call History->Option->Edit*;
- 2) Edit the number before calling.

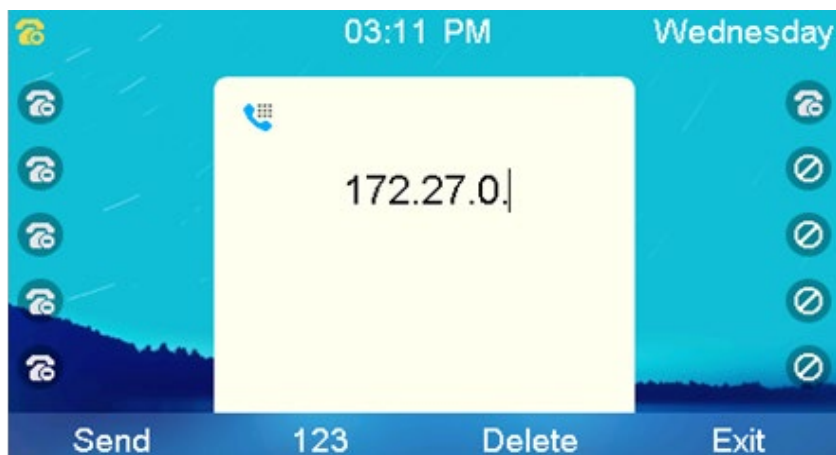
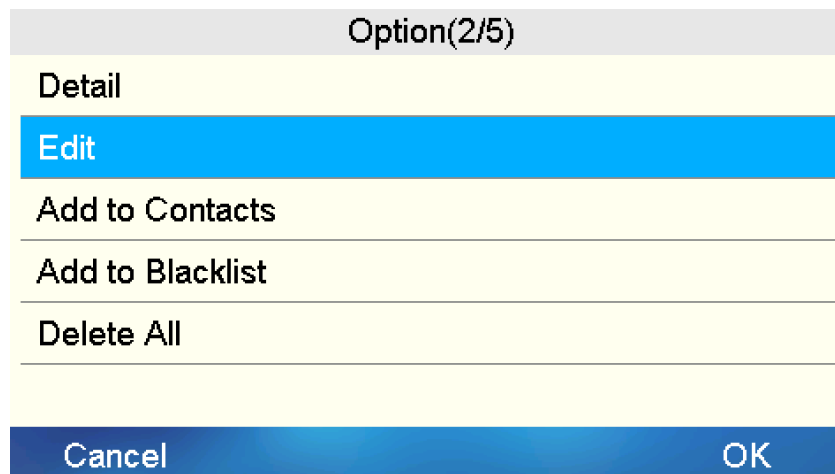

3.28 Echo Testing

You can test whether the hardware of the phone is working properly or not, and can test handfree, handset and headset.

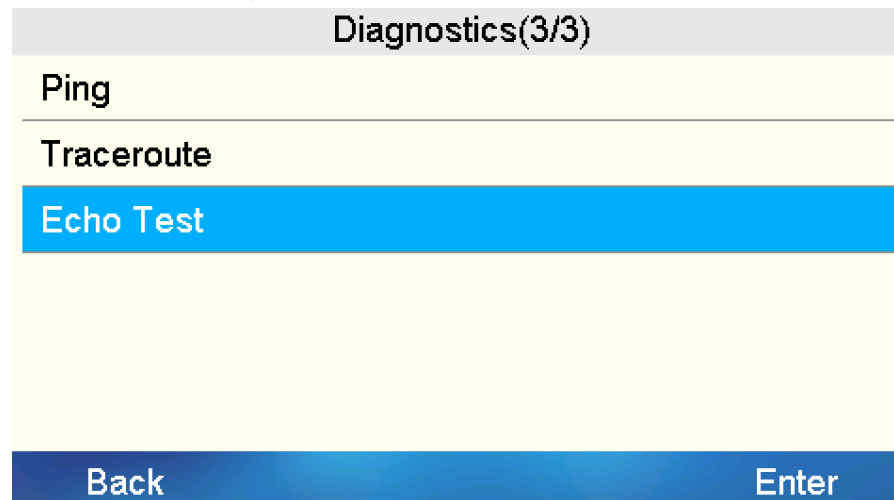

Note:

The user can end the test or return to the phone interface by off-hook.
After the user clicks Echo Test, the phone will enter handfree echo test by default.

3.28.1 Handfree echo

Procedure

- 1) Navigate to *Menu->Functions->Diagnostics->Echo Test*, the phone will enter handfree echo test default.
- 2) You need to speak into the microphone of the phone (voice input hole at the bottom of the phone) to test. If the test voice can be heard, it means the test is successful;
- 3) When the phone is off-hook, you can end the test and return to the phone interface.

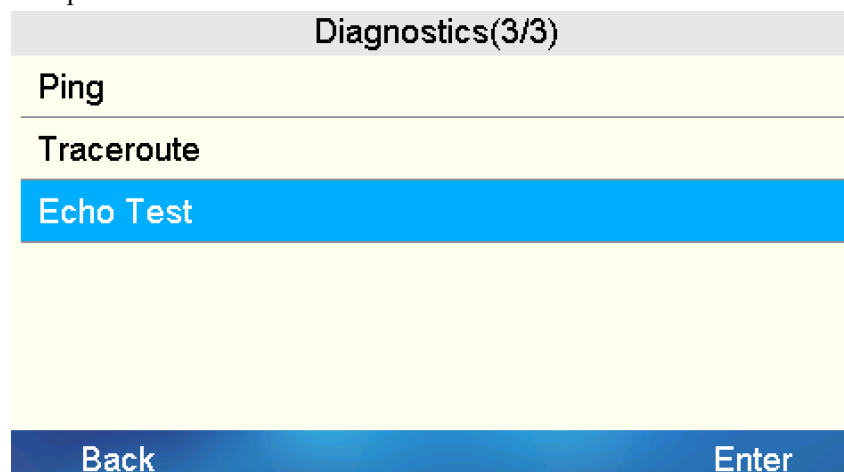



3.28.2 Handset echo

Procedure

- 1) Navigate to **Menu->Functions->Diagnostics->Echo Test**, you need to pick up the handle to enter the handset echo test.
- 2) If the test voice can be heard, it means the test is successful.
- 3) When the phone is off-hook, you can end the test and return to the phone interface.

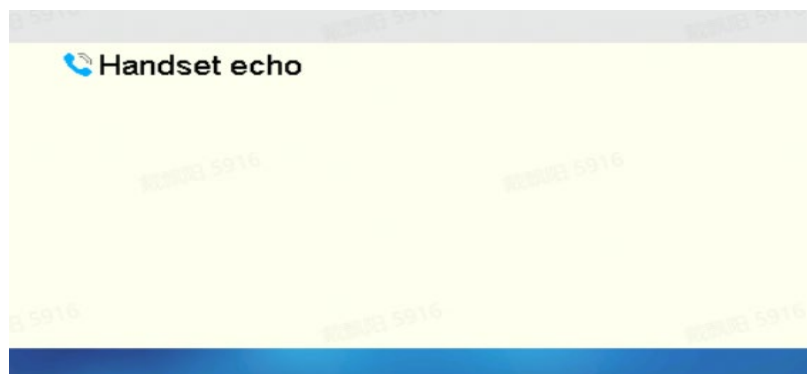

3.28.3 Headset echo

Procedure

- 1) After connecting the headset, navigate to **Menu->Functions->Diagnostics->Echo Test**, you click the headset button on the keyboard of the phone to enter the headset echo test;
- 2) If the test voice can be heard, it means the test is successful.

- 3) When the phone is off-hook, you can end the test and return to the phone interface.

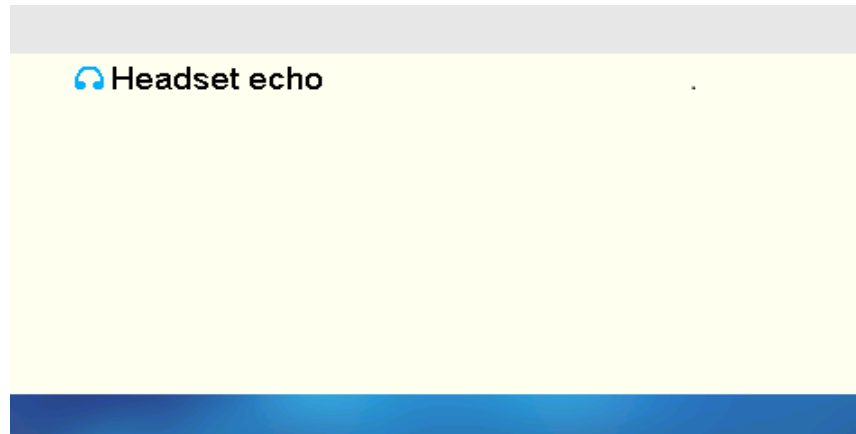

4 Settings

4.1 Basic settings

This part mainly guides users how to complete the settings of related functions and features of the phone through the interactive interface, which is convenient for users to customize services.

You can complete the basic configuration of the phone through *Menu> Settings> Basic Settings*.

4.1.1 Language

The phone provides you with multi-language support, you can change the language through the following methods:

a) Selecting the initial language after resetting to factory

After the administrator reset to factory of your phone, the initial language selection will be displayed on the screen. At this time, select the language you need and click the **OK** soft key. The phone will use the language you selected.

b) Changing language through language setting



Navigate to *Menu> Settings> Basic Settings> Language*, select the language and select **Save**.

4.1.2 Date & Time

The IP phone displays the time and date in the idle. You can set the time and date to be updated automatically from the SNTP server, or you can set the time and date manually.

To configure the SNTP settings via phone user interface:

Procedure

- 1) Navigate to *Menu> Settings> Basic Settings> Date & Time> SNTP Settings*;
- 2) Press the left  /  right key or the **Switch** soft key to select the time zone suitable for your area. The default time zone is “+8 China (Beijing)”;
- 3) Enter the domain name or IP address of the NTP server in the primary server and secondary server respectively;

- 4) (Optional) The daylight save time automatic mode is enabled by default; if you don't need it, you can choose to disable it.
- 5) Press the **Save** soft key to save the setting.





To configure the time and date manually via phone user interface:

Procedure

- 1) Navigate to *Menu> Settings> Basic Settings> Date & Time> Manual Settings*;
- 2) Enter the date and time;
- 3) Press the **Save** soft key to save the settings, and the time and date displayed on the phone screen will be changed.

To configure the date and time format via phone user interface:

Procedure

- 1) Navigate to *Menu> Settings> Basic Settings> Date & Time> Format Settings*;
- 2) Press the left  /  right key or the **Switch** soft key to select the time format (12-hour system or 24-hour system);
- 3) Press the left  /  right key or the **Switch** soft key to select the date format;
- 4) Press the **Save** soft key to save the setting.

The date displayed on the screen will vary depending on the date format. There are six date formats on the phone is displayed as follows:

Data Format	Example(2018/12/24/Mon)
YYYY-MM-DD	2018-12-24
YYYY/MM/DD	2018/12/24
DD-MM-YYYY	24-12-2018
DD/MM/YYYY	24/12/2018
WW-DD-MM	Mon 24 Dec
WW-MM-DD	Mon Dec 24



Note:

When 'Display Mode Setting' is 'Enabled', the time and date displayed on the LCD screen will change accordingly.

To configure the display mode via phone user interface:

Procedure

- 1) Navigate to *Menu >Settings > Basic Setting >Date & Time >Display Mode Setting*.



- 2) Press Left  /  Right key, or the **Switch** soft key to select the desired display mode (Disabled/ Day/ Date/ Day Date) from the Display Mode field.
- 3) Press the **Save** soft key to accept the change or the Back soft key to cancel.

4.1.3 Ring Tones

The ring tone refers to incoming ring tone, which reminds the user that there is an incoming call. The ring tone of IP phone can be set to distinguish from other phones' ring tones; at the same time, the IP phone also supports setting specific incoming ring tone for different contacts.



To configure the ring tone via the phone user interface:

Procedure

- 1) Navigate to *Menu ->Settings ->Basic Setting ->Ring Tones*;
- 2) Press the Up  /  Down key to select the desired ring tone.
- 3) Press the **Save** soft key to accept the change or the **Back** soft key to cancel.

4.1.4 Phone Volume

The Volume key can be used to adjust the volume of handset, speaker phone or headset during a call. The key can also be used to adjust the volume of ring tones when the phone is idle.

Adjust the volume via the phone interface, Press *Menu ->Settings ->Basic Setting ->Phone Volume*. In the Volume Setting interface, access the Handset Volume, Handsfree Volume or Headset Volume, then press the + or - soft key or left  /  right key to adjust the volume. Press the **Save** soft key to save the configuration or press the **Back** soft key to cancel.

4.1.5 Backlight

You can set the brightness (level) of the screen backlight and its duration.



Procedure

- 1) Navigate to Menu >Settings >Basic Setting >Backlight;
- 2) Press the Left / Right key to select a level for the backlight;
 - Press the down key to set duration;
 - Press the Left / Right key to select a value for duration.
- 3) Press the **Save** soft key.

4.1.6 Reboot

Restart the phone:

Procedure

- 1) Navigate to *Menu > Settings > Basic Setting*;
- 2) Press the Up  /  Down key to select **Reboot**;
- 3) Press the **Enter** soft key to reboot.

4.2 Phone Book



The phone supports a variety of phone books to save contact information, including: local phone book, remote phone book, LDAP, and Broad Soft phone book.

4.2.1 Local Phone Book

The Local Phone Book is used for storing the contacts names and number. The IP Phone can store up to 1000 entries contacts and 10 groups in your phone's local phone book. You can add, edit, delete, search, or call any contact from the Local Phone Book.



Adding groups to the Local Phone Book:

Procedure

- 1) Navigate to *Menu > Book*;
- 2) Select **Local Phone Book** and press the **Enter** soft key to enter the Local Group interface;
- 3) Press the **Add** soft key;
- 4) Enter the desired group name in the Group Name field. Press Left  /  Right key, or the **Switch** soft key to select the desired group ring tone from the Ring Tones field. If Auto is selected, this group will use the ring tone assigned;
- 5) Press the **Save** soft key to accept the change or the **Back** soft key to cancel.



Editing a group in the Local Phone Book:

Procedure

- 1) Navigate to *Menu > Book*;
- 2) Select **Local Phone Book** and press the **Enter** soft key to enter the Local Group interface.
- 3) Select the desired contact group.
- 4) Press the **Option** soft key and then select **Detail** from the display list.
- 5) Press Left  /  Right key, or the **Switch** soft key to select the desired group ring tone from the Ring Tones field. If Auto is selected, this group will use the ring tone assigned to the account.
- 6) Press the **Save** soft key to accept the change or the **Back** soft key to cancel.

Adding contact manually

Procedure

- 1) Navigate to **Menu > Book >Local phone book**;
- 2) Select the group (For example: contacts) and press the **Enter** soft key to enter the relevant group interface.
- 3) Press the **Add** soft key to enter the Add Contact interface.
- 4) Enter the name and the office, mobile or other numbers in the corresponding fields.
- 5) Press Left  /  Right key, or the **Switch** soft key to select the desired ringtone, group, account from the corresponding fields.
- 6) Press the **Save** soft key to accept the change or the **Back** soft key to cancel.

Adding contacts from All Calls History

Procedure

- 1) Press the **History** soft key and then select a history from the display list.
- 2) Press the **Option** soft key and then select **Add to Contacts** from the display list.
- 3) Press **OK** soft key to enter the Add Contact interface.
- 4) Press the **Save** soft key to accept the change or the **Back** soft key to cancel.

Searching Contacts

Procedure

- 1) Navigate to *Menu > Book*;
- 2) Select the **Local Phone Book**, Press the **Enter** soft key to enter the Local Phone Book.
- 3) Press the **Search** soft key to search contacts.
- 4) Input keywords such as name, any character of number or whole phone number, press the **Search** soft key to enter the Search Contacts interface.
- 5) The desired contact in the list of displayed results.

4.2.2 Blacklists

The IP phone supports 100 blacklists. You can add, edit, delete, search or call a contact. Any call from the number in the blacklists will be rejected.

Putting a number into Blacklist:

Procedure

- 1) When the IP phone is idle, press *Book > Blacklist > Add*.
- 2) Fill in the phone number;
- 3) Press the **Save** soft key.

4.2.3 Remote Phone Book

Access the remote phone book, add the contacts to the local phone book from the remote phone book or make calls from the remote phone book. 5 URLs of remote phone book is available to set.

Configuring the remote phone book via Web interface:

Procedure

- 1) Navigate to **Phone Book -> Remote Book**.
- 2) Input URL of phone book in Local Book URL field.
- 3) Input the phone book name in Local Book Name field.
- 4) Click the **Submit** key to submit.

Accessing the remote phone book via phone interface:

Procedure





- 1) Navigate to **Book >Remote Phone Book**.
- 2) Select the relevant Remote Group and press the **Enter** soft key. The phone will load the remote group information, and the LCD will display the contacts of this remote group.
- 3) Press the **Back** soft key to unlink.

4.3 History Management

The call history list includes dialed calls, received calls, missed calls and forwarded calls and support 100 logs storage at most. You can check the history, make calls from the calls history and delete the calls history.

Accessing the History via phone interface:

Procedure

- 1) Press the **History** soft key, the screen will display all the recent calls.
- 2) Press the Left  /  Right key to switch the lists of All Calls, Dialed Calls, Received Calls, Missed Calls and Forwarded Calls.
- 3) Press the Up  /  Down key to select the log.
- 4) Press the **Option** soft key and select the **Detail**. The screen will display the detailed information of this log; Press the **Dial** soft key, to make a call from the history; Press the **Option** soft key to add to contacts(Move to Blacklists) from the history; Press the **Delete** soft key to delete calls log from the history; Press the **Option** soft key to select "Delete All" to delete all the call logs from the history.

4.4 Customizing your phone

4.4.1 Programmable Keys

Setting programmable keys via the phone interface

Procedure

- 1) Navigate to *Menu > Features > Programmable Keys*;
- 2) Select the programmable key you will set and press the **Enter** soft key;
- 3) Select key style in the type area;
- 4) Input suitable value in the label area;
- 5) (Optional) Select the relevant account in the account ID area;
- 6) (Optional) Input suitable value in Value area;
- 7) Select the **Save** soft key to save or the **Cancel** soft key to cancel.

4.4.2 SIP Account Management

You can register one SIP account or multiple accounts for your phone, but also can set one or two SIP servers for one account.

Registering an account:

Procedure

- 1) Navigate to *Menu > Settings > Advanced Settings (password: admin@123#) > Account*;
- 2) Select the account you want to set and press the **Enter** soft key;
- 3) Select “Enable” in the active area;
- 4) Input the label, display name, register name, user name, password and SIP server separately;
- 5) Press the **Save** soft key to save or the **Back** soft key to cancel;
- 6) Repeat step 2 to 5 to finish all the account register.

Disabling an Account

Procedure

- 1) Navigate to *Menu > Settings > Advanced setting (password: admin@123#) > Account*.
- 2) Select the account you want to disable and press the **Enter** soft key.
- 3) Select “Disable” in the account active area.
- 4) Press the **Save** soft key to save or the **Back** soft key to cancel.

Note:

Refer to the above steps for other SIP account registration.



4.5 Basic Network Settings

Through the Basic Network setting, you can set the IP Phones to get the IP address by three ways: DHCP, static IP and PPPoE, also can set the VLAN.

4.5.1 LAN Mode

Setting the LAN mode

Procedure



- 1) Navigate to *Menu > Settings > Advanced Settings (password: admin@123#) > Network > LAN Port > LAN Mode*;
- 2) Press the up  /  down keys to select the "IPv4" or "IPv6";
- 3) Press **Save** soft key to save.

Note: you need to reboot to take effect after modifying.

4.5.2 DHCP Mode

Configuring the DHCP Mode:



Procedure

- 1) Navigate to *Menu > Settings > Advanced Setting (password: admin@123#) > Network > LAN Port > IPv4 / IPv6*;
- 2) Press the Up  /  Down key on the phone keyboard to select DHCP (default is DHCP).
- 3) Press the **Enter** soft key to enter the DHCP switch interface, it will auto return to last interface after seconds.

4.5.3 Static IP Mode

Configuring the Static IP Mode:



Procedure

- 1) Navigate to *Menu > Settings > Advanced Setting (password: admin@123#) > Network > LAN Port > IPv4 / IPv6*;
- 2) In the LAN Port interface, press the Up  /  Down key to select Static IP, then Press the Enter soft key to enter Static IP Setting interface;
- 3) Input the IP address, Subnet mask, Gateway, DNS 1 and DNS 2 in the corresponding area.
- 4) Press the **Save** soft key to save.

4.5.4 PPPoE Mode

Configuring the PPPOE Mode:





Procedure

- 1) Navigate to *Menu > Settings > Advanced Setting (password: admin@123#) > Network > LAN Port > IPv4 / IPv6;*
- 2) In the LAN Port interface, press the Up  /  Down key to select PPPoE, then Press the Enter soft key to enter PPPoE Setting interface;
- 3) Enter the username and password in the corresponding fields;
- 4) Press the **Save** soft key to save.

4.5.5 Configure VLAN





Enabling the LAN Port:

Procedure

- 1) Navigate to *Menu > Settings > Advanced Setting (password: admin@123#) > Network > VLAN Port > LAN Port.*
- 2) Press the Left  /  Right key or “Switch” soft key to select **Enable** in the LAN Port activation field.
- 3) Press the Up  /  Down key to enter the VID and Priority in the corresponding fields.
- 4) Press **Save** soft key to reboot (Setting will take effect after reboot, if cancel the reboot, the settings will be saved but not take effect).

Enabling the PC Port:



Procedure

- 1) Navigate to *Menu > Settings > Advanced Setting (password: admin@123#) > Network > VLAN Port > PC Port;*
- 2) Press the Left  /  Right key or “Switch” soft key to select **Enable** in the PC Port activation field.
- 3) Press the Up  /  Down key to enter the VID and Priority in the corresponding fields.
- 4) Press **Save** soft key to reboot (Setting will take effect after reboot, if cancel the reboot, the settings will be saved but not take effect) .

4.6 Web Server

Configuring the Web Server:

Procedure

- 1) Navigate to *Menu > Settings > Advanced Setting (password: admin@123#) > Web Server;*
- 2) Press the Left  /  Right key or “Switch” soft key to select **Enable** in the Web Server activation field.
- 3) Press the **Save** soft key to save or the **Back** soft key to cancel.

4.7 Reset to Factory

Reset to Factory:

Procedure

- 1) Navigate to *Menu > Settings > Advanced Setting* (password: *admin@123#*);
- 2) Press the **Enter** soft key to access the reset to factory.

4.8 Password Setting

This feature is used to set the password for advanced settings

Procedure

- 1) Navigate to *Menu > Settings > Advanced Settings* (password: *admin@123#*) > *Password Settings*;
- 2) Enter the current password, new password and confirm password in the corresponding area;
- 3) Press **Save** soft key to set.

4.9 Auto Provision

Setting automatic update version for phone:

Procedure

- 1) Navigate to *Menu > Settings > Advanced Settings* (password: *admin@123#*) > *Auto Provision*;
- 2) Enter the URL and set the mode, etc.;
- 3) Press **Save** soft key to save.

5 Web Interface

5.1 Login & Logout

The Web system of the IP Phone is designed for users or administrators to configure or manage IP phones.

Access the web interface:

Users can access the web interface through two ways:

- Access the Web interface through the LAN port
- Access the Web interface through the NMS network management system when it is not available through the LAN port

Access the Web interface through the LAN port

- 1) Press **Menu >Status** to view the IP address of the phone.
- 2) Input the IP address of the phone (such as http://172.31.2.167) in the browser address box and press Enter.
- 3) If successfully connected to the IP phone, The login GUI will be displayed. On this page, enter the correct username and password. By default, username and password are as below:

User Name: admin

Password: admin@123#

Access the Web interface through the NMS network management system

If users cannot access web interface through LAN port and need to access the web interface through 4G network. First, users need to access the Dinstar NMS network management system and add 4G IP Phones to the NMS. And then users can login phone interface and configure the parameters through the NMS. If users want to get more details, please refer to the 4G IP Phone related configuration guide or contact technical support.

Log out:

You can log out of the web system by clicking log out in the upper right corner of the window.

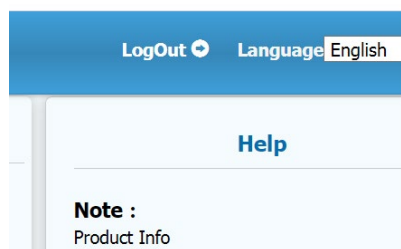

5.2 Status

5.2.1 Status->Basic

Product Information	
Model	G100
MAC Address	F8:A0:3D:10:2C:2D
SN	DEE4-A100-2026-0209
Firmware Version	2.100.11.13.0
Hardware Version	100.2.1.0.2.1.6.0
Network Information	
Mode(IPv4/IPv6)	IPv4
IPv4	
Type	DHCP
IP Address	172.28.200.221
Subnet Mask	255.255.0.0
Gateway	172.28.1.1
DNS1	172.28.1.1
DNS2	61.139.2.69
Account Information	
Account1	100670@172.28.21.111
Account2	Registered
	None@None
	Disabled
Other	
LAN Link Status	Connected
LAN Speed and Duplex	100Mbps FullDuplex
System Uptime	15:38:03
Primary NTP	1.pool.ntp.org
Secondary NTP	2.pool.ntp.org
VPN Status	Disabled
NMS Status	Offline
VLAN ID	NULL

Sections	Description
Product Information	It provides the device's information such as Model name, MAC address (IP device's physical address), Firmware version and Hardware version.

Sections	Description
Network Information	Show you the network mode (LAN port) of the device.
IPv4	It provides the information of the LAN port IPv4 type (may be DHCP/static/PPPoE), IP address, subnet mask, gateway, preferred DNS server and alternative DNS server.
IPv6	It provides the information of the LAN port IPv6 type (may be DHCP/static/PPPoE), IP address, gateway, preferred DNS server and alternative DNS server.
4G	It provides the information of the 4G mobile network such as Link Status, Register Status, PDP Address, IP Address, Signal, IMSI and Number.
Account Information	It provides the device's Account information and Registration status (account username, registered server's address, and Register result).
Others	Show you LAN port connection status, running time, primary NTP server, secondary NTP server (NTP server is used to automatically synchronize time from the Internet), VPN status and NMS status.

5.2.2 Status->Wi-Fi Status (only for Wi-Fi IP Phone)

Wi-Fi Status	
Enable Status	Enabled
Connect Status	Connected
SSID	comsns
Signal Strength	-53
AP Mac Address	cc:08:fb:b3:e8:76
Security Mode	WPA/WPA2-PSK
Security Type	CCMP
Frequency	5240
Network Information	
Mode(IPv4/IPv6)	IPv4
IPv4	
Type	DHCP
IP Address	192.168.1.121
Subnet Mask	255.255.255.0
Gateway	192.168.1.1
DNS1	61.139.2.69
DNS2	8.8.8.8

Sections	Description
Wi-Fi Status	It provides the information of WiFi Status such as Enable Status, Connect Status, SSID, Signal Strength, AP Mac Address, Security Mode, Security Type and Frequency.
Network	Show you the network mode of Wi-Fi Network.

Sections	Description
Information	
IPv4	It provides the information of the IPv4 such as Type (DHCP/Static IP), IP Address, Subnet Mask, Gateway, DNS1 and DNS2.

5.3 Account

5.3.1 Account->Basic

The screenshot shows the 'SIP Account' configuration page. On the left is a sidebar with navigation options: Basic (selected), Sip Param, Advanced, and Codecs. The main content area is titled 'SIP Account' and contains the following sections:

- SIP Account:** Status (Registered), Account (Account1: 8003), Active (Enabled), Display Label (8003), Display Name (8003), Register Name (8003), Username (*) (8003), Password (*****).
- SIP Server 1:** Server IP (*) (172.27.10.23), Port (5060), Registration Expires (*) (1800, 30~65535s).
- SIP Server 2:** Server IP, Port (5060), Registration Expires (1800, 30~65535s).
- SIP Server 3:** Server IP, Port, Registration Expires (30~65535s).
- Registration Params:** Registration Type (Concurrent), Registration Fallback (Disabled), SIP Registration Retry Timer (30, 1~1800s).
- Outbound Proxy Server:** Active (Disabled), Server IP, Port (5060), Backup Server IP, Port (5060), Proxy Fallback Active (Disabled), Proxy Fallback Interval (3600, 35~65535s).
- Transport Type:** Transport Type (UDP).
- NAT:** NAT Type (Disabled), Stun Server Address, Port (3478), Static NAT Address, Via Use Type (NAT Address), SDP Use Type (NAT Address).
- VPN:** VPN Preferred (Enabled).

At the bottom of the form are 'Submit' and 'Cancel' buttons.

Sections	Description
SIP Account	For the specified account settings. <ul style="list-style-type: none"> Status: To display register result.

Sections	Description
	<ul style="list-style-type: none"> • Account: SIP account • Active: To enable or disable SIP account • Display Label: Which is displayed on the phone's • Display Name: Which is sent to the other call party for display. • Register Name: Allocated by SIP server provider, used for authentication. • Username: the extension name assigned by the SIP server. • Password: Used for authorization.
SIP Server 1	<p>For the primary SIP server settings.</p> <ul style="list-style-type: none"> • Server IP: SIP server address, it could be an URL or IP address. • Registration Expires: The registration will expire after Registration period, the IP phone will re-register automatically within registration period.
SIP Server 2	<p>For the secondary SIP server 2 settings.</p> <p>This is for redundancy, if registering to Primary SIP server fails, the IP phone will go to Secondary SIP server 2 for registering.</p> <p>Note: Secondary SIP server 2 is used for redundancy, it can be left blank if there is not redundancy SIP server in user's environment.</p>
SIP Server 3	<p>For the secondary SIP server 3 settings.</p> <p>This is for redundancy, if registering to Primary SIP server 1 and Secondary SIP server 2 fails, the IP phone will go to Secondary SIP server for registering.</p> <p>Note: Secondary SIP server 2 is used for redundancy, it can be left blank if there is not redundancy SIP server in user's environment.</p>
Registration Params	<p>For the registration params settings.</p> <ul style="list-style-type: none"> • Registration Type: Set the registration type, can set Concurrent / Successive • Registration Fallback: When the registration type is

Sections	Description
	<p>successive, we can enable registration fallback;</p> <ul style="list-style-type: none"> • SIP registration retry time: Set the SIP registration retry time (1~1800 seconds).
Outbound Proxy Server	<p>For the Outbound Proxy server settings. An outbound proxy server is used to receive all initiating request messages and route them to the designated SIP server.</p> <p>Note: If configured, all SIP request messages from the IP phone will be sent to the outbound proxy server forcefully.</p>
Transport Type	<p>It configures Transport type for SIP message</p> <ul style="list-style-type: none"> • UDP: UDP is an unreliable but very efficient transport layer protocol. • TCP: Reliable but less-efficient transport layer protocol. • TLS: Secured and Reliable transport layer protocol.
NAT	<p>Display and configure NAT (Network Address Translator). NAT is the general term for techniques that establish and maintain IP connections through a NAT gateway. STUN is one NAT traversal technique that allows a client behind a NAT to discover its public address.</p> <ul style="list-style-type: none"> • NAT types: options: Disabled / STUN / Static NAT / Dynamic NAT. • STUN: Short for Simple Traversal of UDP over NATS, a solution to solve NAT issues. • Static NAT address: static NAT address. • Via usage type: options: Local address / NAT address. • SDP usage type: options: Local address / NAT address. <p>Note: NAT is disabled by default.</p>
VPN	<p>For a specific account configure VPN options.</p> <ul style="list-style-type: none"> • VPN preferred: If enabled, the designated account will preferentially use the VPN address for communication. If disabled, the specified account uses the local address to communicate. <p>Note: By default, VPN priority is enabled.</p>

5.3.2 Account->SIP Param

<ul style="list-style-type: none"> Basic Sip Param Advanced Codecs 	<p>SIP Account</p> <p>Account: <input type="text" value="Account1: 8003"/></p> <p>Service Param</p> <p>Min Local SIP Port: <input type="text" value="20000"/> (1024~65535)</p> <p>Max Local SIP Port: <input type="text" value="20299"/> (1024~65535)</p> <p>Use New SIP Port When Registration Fail: <input type="text" value="Enabled"/></p> <p>Call without Registration: <input type="text" value="Disabled"/></p> <p>MWI Subscribe: <input type="text" value="Disabled"/></p> <p>MWI Subscribe Period: <input type="text" value="1800"/> (120~65535s)</p> <p>Voice Mail Number: <input type="text" value="*170*2#"/></p> <p>BLF Expire: <input type="text" value="1800"/> (120~65535s)</p> <p>ACD Expire: <input type="text" value="1800"/> (120~65535s)</p> <p>Caller ID Header: <input type="text" value="FROM"/></p> <p>Auto Answer: <input type="text" value="Disabled"/></p> <p>Ringtones: <input type="text" value="Default"/></p> <p>PTIME: <input type="text" value="20"/></p> <p>Anonymous Call: <input type="text" value="Disabled"/></p> <p>Anonymous Call Rejection: <input type="text" value="Disabled"/></p> <p>Rejection Code for Anonymous Call: <input type="text" value="433 (Anonymity D)"/></p> <p>Privacy Number: <input type="text" value="None"/></p> <p>Missed Call Display on LCD: <input type="text" value="Enabled"/></p> <p>Trust SIP Server Only: <input type="text" value="Disabled"/></p> <p>DNS Query Mode: <input type="text" value="A/AAAA"/></p> <p>DNS Cache: <input type="text" value="Enabled"/></p> <p>DNS Cache Time(0:Not Refresh): <input type="text" value="0"/> (0~3600s)</p> <p>Sync Time from SIP Server: <input type="text" value="Disabled"/></p> <p>SIP Registration Expires (Percentage): <input type="text" value="50"/> (10%~90%)</p> <p>SIP Request Retry Count: <input type="text" value=""/></p> <p>Compatibility Param</p> <p>User-Agent: <input type="text" value=""/></p> <p>PRACK: <input type="text" value="Disabled"/></p> <p>PRACK Only for 18x with SDP: <input type="text" value="Disabled"/></p> <p>Invite with user=phone: <input type="text" value="Disabled"/></p> <p>INVITE with P-Preferred-Identity Header(RFC3325): <input type="text" value="Disabled"/></p> <p>TLS version: <input type="text" value="Adaptive"/></p> <p>Session Timer: <input type="text" value="Disabled"/></p> <p>Session Expire: <input type="text" value="1800"/> (90~7200s)</p> <p>Session Refresher: <input type="text" value="UAC"/></p> <p>Session Refresh Method: <input type="text" value="UPDATE"/></p> <p>Use IPv6 Stateless Address: <input type="text" value="Enabled"/></p> <p>Unregister When Reboot: <input type="text" value="Disabled"/></p> <p>Escape special characters in URL: <input type="text" value="Enabled"/></p> <p>Send MAC Info: <input type="text" value="Disabled"/></p> <p>MAC Header Separator: <input type="text" value=":"/></p> <p>Displayname With Quotes: <input type="text" value="Enabled"/></p> <p>RTP Mode in SDP when Call Holding: <input type="text" value="sendonly"/></p> <p>Value of 'Refer To' refers to 'Contact': <input type="text" value="Disabled"/></p> <p>Third Party Do Not Send 18x Response: <input type="text" value="Disabled"/></p> <p>Support P-Early-Media: <input type="text" value="Enabled"/></p> <p>18x Response Preferred: <input type="text" value="18x Response witi"/></p> <p>Support eSpace Linkage: <input type="text" value="Disabled"/></p>
---------------------------------------------------------------------------------------------------------------------	------------------------------------------------------------------------------------------------------------------------------------------------------------------------------------------------------------------------------------------------------------------------------------------------------------------------------------------------------------------------------------------------------------------------------------------------------------------------------------------------------------------------------------------------------------------------------------------------------------------------------------------------------------------------------------------------------------------------------------------------------------------------------------------------------------------------------------------------------------------------------------------------------------------------------------------------------------------------------------------------------------------------------------------------------------------------------------------------------------------------------------------------------------------------------------------------------------------------------------------------------------------------------------------------------------------------------------------------------------------------------------------------------------------------------------------------------------------------------------------------------------------------------------------------------------------------------------------------------------------------------------------------------------------------------------------------------------------------------------------------------------------------------------------------------------------------------------------------------------------------------------------------------------------------------------------------------------------------------------------------------------------------------------------------------------------------------------------------------------------------------------------------------------------------------------------------------------------------------------------------------------------------------------------------------------------------------------------------------------------------------------------------------------------------------------------------------------------------------------------------------------------------------------------------------------------------------------------------------------------------------------------------------------------------------------------------------------------------------------------------------------------------------------------------------------------------------------------------------------------------------------------------------------------------------------------------------------------------------------------------------------------------------------------------------------------------------------------------------------------------------------------------------------------------------------------------------------------------------------------------------------------------------------------------------------------------------------------------------------------------------------------------------------------------------------------------------------------------------------------------

Sections	Description
SIP Account	Show you current Account settings or to select which account to display.
Service Param	<p>SIP service parameters, which are used to expand device functions.</p> <ul style="list-style-type: none"> • Min Local SIP Port: supported minimum local SIP port value • Max Local SIP Port: supported maximum local SIP port value • Use New SIP Port When Registration Fail: enable or disable re-randomizing ports when registration times out

Sections	Description
	<ul style="list-style-type: none"> • Call without Registration: enable or disable calls without registration • MWI Subscribe: when the phone account registers successfully, enable MWI to have the phone send SUBSCRIBE to the server for voicemail notifications • MWI Subscribe Period: subscription interval (120–65535 seconds) • Voice Mail Number: voicemail mailbox number • BLF Expire: BLF subscription interval (120–65535 seconds) • ACD Expire: ACD subscription interval (120–65535 seconds) • Caller ID Header: selectable caller ID header • Auto Answer: enable or disable auto answer • Ringtones: selectable ringtone • PTime: set the length of voice data per packet • Anonymous Call: enable or disable anonymous calling • Anonymous Call Rejection: enable or disable rejecting anonymous calls • Rejection Code for Anonymous Call: supports 404 (Not Found), 408 (Request Timeout), 433 (Anonymity Disallowed), 480 (Temporarily Unavailable), 486 (Busy Here), 487 (Request Terminated), 600 (Busy Everywhere), 603 (Decline); default is 433 (Anonymity Disallowed) • Privacy Number: selectable number privacy type • Missed Call Display on LCD: enable or disable missed calls feature • Trust SIP Server Only: enable or disable trusting only the SIP server • DNS Query Mode: select DNS query method

Sections	Description
	<ul style="list-style-type: none"> • DNS Cache: enable or disable DNS caching • DNS Cache Time: set DNS cache time (0–3600 seconds) • Sync Time from SIP Server: enable or disable syncing phone time • SIP Registration Expires: refresh registration based on a percentage of the registration duration • SIP Request Retry Count: retransmission count for INVITE and REGISTER requests. Setting to 0 means no retransmission limit; follow the SIP protocol’s standard retransmission behavior.
Compatibility Param	<p>SIP compatibility parameters, which are used to be compatible with special scenarios or special servers.</p> <ul style="list-style-type: none"> • User-Agent: user agent name • PRACK: Choose whether to enable PRACK (Provisional Response Acknowledgement). When enabled, the phone will send PRACK requests for provisional responses requiring reliable transmission (1xx with Require: 100rel or RSeq) to acknowledge receipt, ensuring that important provisional information (such as early media SDP) is not lost. • PRACK Only for 18x with SDP: Send PRACK only when provisional responses (18x, e.g., 180/183) include SDP (media description); do not send PRACK for other 1xx responses that contain only indications (e.g., 180 without SDP) or lack SDP. • Invite with user=phone: if enabled, the IP phone will send user=phone in SIP messages • INVITE with P-Preferred-Identity Header (RFC3325) • TLS version: select TLS version • Session Timer: enable or disable session timer • Session Expire: configure session expiration time (90–7200 seconds) • Session Refresher: select session refresher

Sections	Description
	<ul style="list-style-type: none"> • Session Refresh Method: select session refresh method • Use IPv6 Stateless Address: enable or disable use of IPv6 stateless address • Unregister When Reboot: enable or disable logging out first after reboot • Escape special characters in URL: enable or disable escaping special characters in URLs • Send MAC Info: enable or disable adding the MAC address to the SIP header of REGISTER messages • MAC Header Separator: set the separator character used between MAC address bytes as needed • Displayname With Quotes: enable or disable using quotes for the display name • RTP Mode in SDP when Call Holding: select RTP mode when a call is on hold • Value of 'Refer To' refers to 'Contact': enable or disable 'Refer To' referencing 'Contact' content • Third Party Do Not Send 18x Response: enable or disable third party not sending 18x responses • Support P-Early-Media: enable or disable support for P-Early-Media • 18x Response Preferred: select preferred 18x response type • Support eSpace Linkage: enable or disable support for eSpace phone linkage

5.3.3 Account->Advanced

Sections	Description
SIP Account	Show you current Account settings or to select which account to display.
Hotline	<p>The hotline allows users to automatically dial a defined number after hearing a dial tone without dialing any number.</p> <ul style="list-style-type: none"> • Active: Enable or disable the hotline function. • Number: Set the defined hotline number. • Delay Time: Set the interval for automatic outgoing calls after hearing the dial tone.
Keep Alive	<ul style="list-style-type: none"> • Active: When enabled, it will send an Option message to the server; • Keep Alive Interval: The interval time between sending option messages; • Keep Alive Error Code: A response code used to determine network failures.
DTMF	It configures DTMF feature.

Sections	Description
	<ul style="list-style-type: none"> • Type: Support Inband, Info, RFC2833 or their combinations. • DTMF Info Type: Only available when DTMF Type is Info. • DTMF Payload: To configure payload type for DTMF. <p>Note: By default, DTMF type is RFC2833 which is the standard. Type Inband uses inband frequency to indicate DTMF tone which is most used to be compatible with traditional telephone server. Type Info use SIP Info message to indicate DTMF message.</p>
Encryption	<p>It enables or disables SRTP feature.</p> <ul style="list-style-type: none"> • SRTP: If enabled, all audio signal (technically speaking it's RTP streams) will be encrypted for more security.
NAT	<p>NAT-related settings.</p> <ul style="list-style-type: none"> • UDP Keep Alive message: If enabled, IP phone will send UDP keep-alive message periodically to router to keep NAT port alive. • UDP Alive Msg Interval: Keep alive message interval.
Conference	<p>To select Local or network conference.</p> <ul style="list-style-type: none"> • Type: To select desired conference type • Conference URI: If network conference is selected, a network conference URI is needed.
Music Server	<p>It configures third-party MOH (music-on-hold) server.</p> <ul style="list-style-type: none"> • Active: To enable or disable this MOH server, If enabled, the IP phone will play MOH from configured server. • Music Server: To configure MOH server address.
BLF List	<p>It configures BLF List URI address.</p> <ul style="list-style-type: none"> • BLF List URI: BLF List is short for Busy Lamp Field List. • BLF List PickUp Code: To set the BLF pick up code. • BLF List Barge In Code: To set the BLF barge in code.

Sections	Description
Broadsoft	<p>It configures Broadsoft AOC feature.</p> <ul style="list-style-type: none"> AOC: A feature used to be accounting on Broadsoft platform. <p>Note: Please consult your administrator further information.</p>

5.3.4 Account-> Codecs

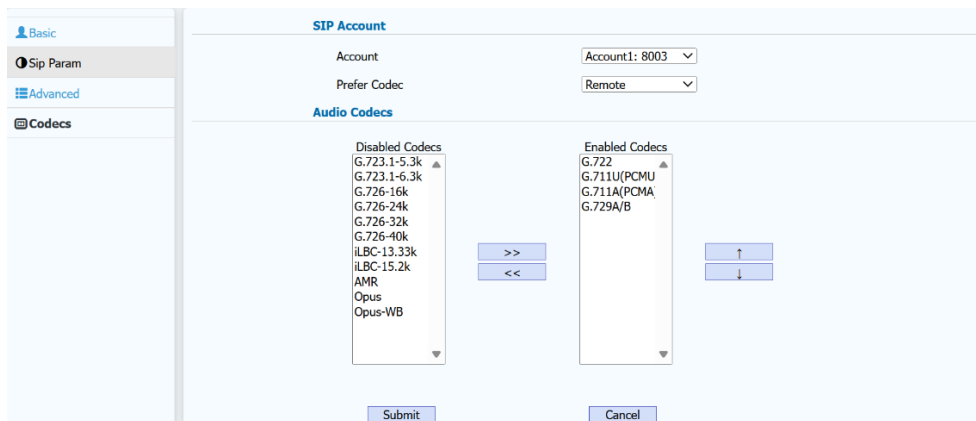

Sections	Description
SIP Account	Show you current Account settings or to select which account to display.
Audio Codecs	To display and configure available/unavailable codecs list. Codec means coder-decoder which is used to transfer analog signal to digital signal or vice versa. Familiar codecs are PCMU(G.711U), PCMA(G.711A), G.722(wideband codecs), G.729A/B, G.723_5.3k, G.723_6.3k, G.726_16k, G.726_24k, G.726_32k, G.726_40k, iLBC-13.33k, iLBC-15.2k, AMR, Opus, Opus-WB.

5.4 Network

5.4.1 Network->Basic

The screenshot displays the 'Basic' configuration page for network settings. It is divided into several sections:

- LAN Port Mode:** A dropdown menu is set to 'IPv4'.
- LAN Port IPv4:**
 - DHCP:** Selected with a radio button. Fields for IP Address (172.23.167.3), Subnet Mask (255.255.0.0), and Default Gateway (172.23.1.1) are filled.
 - Static IP:** Unselected.
 - Static DNS:** Radio buttons for 'ON' and 'OFF' are present.
 - DNS1:** Field contains 8.8.8.8.
 - DNS2:** Field is empty.
- LAN Port IPv6:**
 - DHCP:** Selected with a radio button. Fields for IP Address, Prefix Length, and Default Gateway are empty.
 - Static IP:** Unselected.
 - Static DNS:** Radio buttons for 'ON' and 'OFF' are present.
 - DNS1:** Field is empty.
 - DNS2:** Field is empty.
- LAN PPPoE:**
 - PPPoE:** Unselected with a radio button.
 - Username:** Field is empty.
 - Password:** Field contains eight asterisks (*****).
- Speed and Duplex:**
 - LAN port:** Dropdown menu set to 'Auto Negotiation'.
 - PC port:** Dropdown menu set to 'Auto Negotiation'.

Sections	Description
LAN Port Mode	It configures LAN port mode, IPv4, IPv6, IPv4&IPv6 are optional.
LAN Port IPv4	It configures the LAN port IPv4: <ul style="list-style-type: none"> • DHCP: If enabled, the IP phone will automatically obtain the IP address, subnet mask, default gateway and DNS server address from the DHCP server. • Static IP: If enabled, you must manually set the IP address, subnet mask, default gateway and DNS server.
LAN Port IPv6	It configures the LAN port IPv6: <ul style="list-style-type: none"> • DHCP: If enabled, the IP phone will automatically obtain the IP address, prefix length, default gateway and DNS server addresses from the DHCP server. • Static IP: If enabled, you must manually set the IP address, prefix length, default gateway and DNS server.
LAN PPPoE	LAN PPPoE settings: <ul style="list-style-type: none"> • PPPoE: Use PPPoE username & password to connect to PPPoE server.
Speed and Duplex	Set the network full-duplex, half-duplex and speed

5.4.2 Network->Advanced

The screenshot shows the 'Advanced' configuration page for a Dinstar device. The left sidebar contains navigation options: Basic, Advanced (selected), TR069, SNMP, NMS, VLAN&QoS, 802.1X, and Diagnosis. The main content area is titled 'LLDP' and includes the following sections:

- LLDP:** Active (Enabled), Packet Interval (60, range 10-3600s).
- Local RTP:** Min RTP Port (12000, range 1024-65535), Max RTP Port (12004, range 1024-65535).
- Web Service:** Web Type (HTTPS), HTTP Port (80, range 80-65535), HTTPS Port (443, range 443-65535).
- DHCP Option:** Option 12 (Hostname) (empty), TR069 Option (246, range 0-254), TR069 URL Prefix (acs.address=).
- Registration Random:** Registration Random Time (5, range 0-60s).
- SSH:** Active (Enabled).
- OpenVPN:** Active (Enabled), Upload(<50K) (Browse vpn.conf, Upload button).

At the bottom of the page, there are 'Submit' and 'Cancel' buttons.

Sections	Description
LLDP	<p>It configures LLDP feature.</p> <ul style="list-style-type: none"> Active: To enable or disable LLDP feature. Packet Interval: To configure the interval for LLDP admin message. <p>Note: LLDP stands for Link Layer Discovery Protocol, it is used to exchange device information between any two directly-connected devices. LLDP is often used to configure Voice VLAN automatically for IP phone.</p>
Local RTP	<p>Local RTP settings.</p> <ul style="list-style-type: none"> Max RTP Port: Determine the maximum port that RTP stream can use. Min RTP Port: Determine the minimum port that RTP stream can use.
Web Service	<p>Web Service settings.</p> <ul style="list-style-type: none"> Web Type: To select web type such as Http or Https. HTTP Port: Enter HTTP Port, the default is 80. HTTPS Port: Enter HTTPS Port, the default is 443.
DHCP Option	<ul style="list-style-type: none"> Option 12 (Hostname): Custom phone host name (if blank, host name is phone model).

	<ul style="list-style-type: none"> • TR069 Option: Set TR069 Option, the default is 246. • TR069 URL Prefix: Set TR069 URL Prefix.
Registration Random	Registration Random Time.
SSH	To display and configure SSH settings: <ul style="list-style-type: none"> • Active: enable or disable this function.
OpenVPN	VPN settings. <ul style="list-style-type: none"> • Active: To enable or disable VPN feature. • Upload: To upload VPN client configuration file which is used to connect to VPN server. <p>Note: For now, IP phone can only support OpenVPN.</p>

5.4.3 Network ->Wi-Fi (only for Wi-Fi IP Phone)

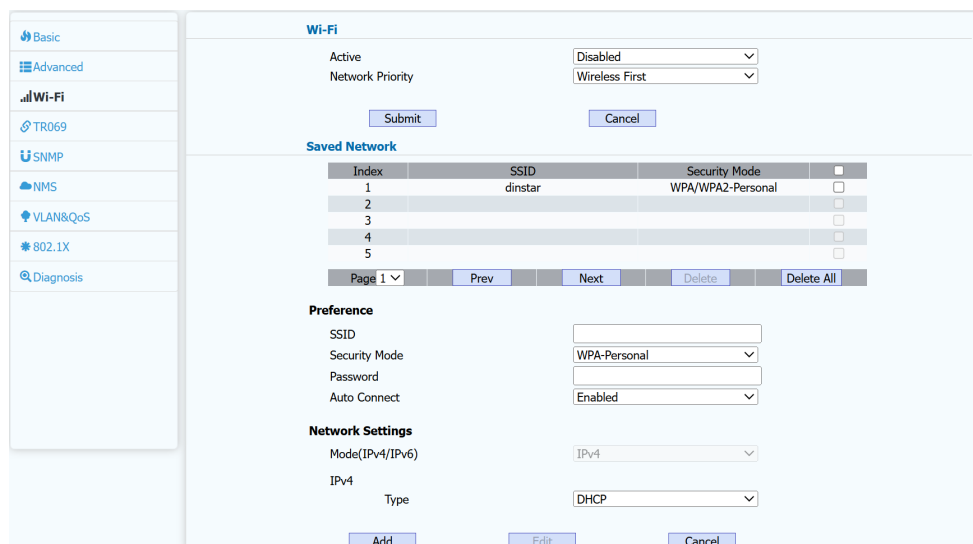

Sections	Description
Wi-Fi	To configure the Active and Network Priority of the Wi-Fi Network. <ul style="list-style-type: none"> • Active: Enable or disable the Wi-Fi function • Network Priority: Choose whether wired or wireless network has priority for data;
Saved Network	You can configure Preference and Network settings. Preference includes SSID, Security Mode, Password and Auto Connect. <ul style="list-style-type: none"> • SSID: SSID value

	<ul style="list-style-type: none"> • Security Mode: Supported security modes • Auto Connect: Choose whether to enable Wi-Fi auto-connect <p>Network settings includes:</p> <ul style="list-style-type: none"> • Mode (IPv4/IPv6): Set the wireless network IPv4 mode (IPv6 not supported) • Type (DHCP/Static IP): Address acquisition method (Static IP or DHCP).
--	--------------------------------------------------------------------------------------------------------------------------------------------------------------------------------------------------------------------------------------------------------------------------------------------------------------------------------------------------------------------------------------------------------------------

5.4.4 Network ->TR069

Sections	Description
----------	-------------

TR069	<p>TR069 settings.</p> <ul style="list-style-type: none"> • Active: To enable or disable TR069 feature. • Version: To select supported TR069 version (version 1.0 or 1.1). • URL: To configure URL address for ACS. • User name: To configure username for ACS. • Password: To configure Password for ACS. <p>Periodic Inform: To enable periodically inform.</p> <ul style="list-style-type: none"> • Periodic Interval: To configure interval for periodic inform. <p>CPE: CPE is short for Customer-premise equipment as client devices.</p> <ul style="list-style-type: none"> • URL: To configure URL address for CPE. • User name: To configure username for CPE. • Password: To configure Password for CPE. <p>Note: TR-069(Technical Report 069) is a technical specification entitled CPE WAN Management Protocol (CWMP). It defines an application layer protocol for remote management of end-user devices.</p>
--------------	--------------------------------------------------------------------------------------------------------------------------------------------------------------------------------------------------------------------------------------------------------------------------------------------------------------------------------------------------------------------------------------------------------------------------------------------------------------------------------------------------------------------------------------------------------------------------------------------------------------------------------------------------------------------------------------------------------------------------------------------------------------------------------------------------------------------------------------------------------------------------------------------------------------------------------------------------------------------------------------------------------------------------------------

5.4.5 Network ->SNMP

Sections	Description
SNMP	<p>SNMP settings.</p> <ul style="list-style-type: none"> • Active: To enable or disable SNMP feature. • Version: Select the supported SNMP version. It supports v1/v2c

	<p>and v3.</p> <ul style="list-style-type: none"> • Trusted IP: To configure allowed SNMP server address, it could be an IP address or any valid URL domain name. • Username: Set username • Authentication Type: Set Authentication Type including None, MD5 and SHA. • Authentication Password: Set Authentication Password. • Encryption Type: Set Encryption Type including None, DES, AES and AES128. • Encryption Password: Set Encryption Password. <p>Note: SNMP (Simple Network Management Protocols) is Internet-standard protocol for managing devices on IP networks.</p>
--	----------------------------------------------------------------------------------------------------------------------------------------------------------------------------------------------------------------------------------------------------------------------------------------------------------------------------------------------------------------------------------------------------------------------------------------------------------------------------------------------------------------------------------------------------------------------------------------------------------------------------------------------------------

5.4.6 Network ->NMS

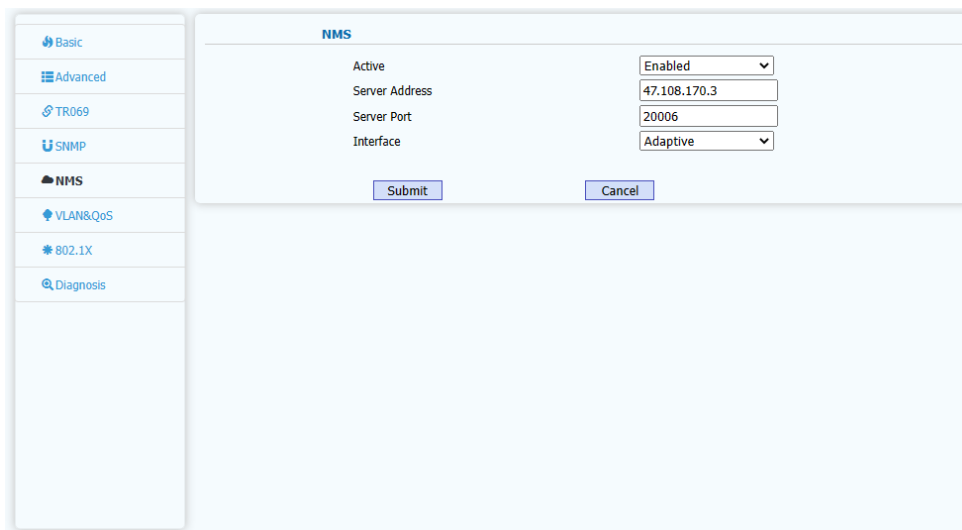

Sections	Description
NMS	<p>It configures NMS feature.</p> <ul style="list-style-type: none"> • Active: Enable or disable NMS function. • Server Address: The address of the NMS server. • Server Port: The port of the NMS server. • Interface: Configure the local interface for accessing the NMS server, which is default in DHCP and static IP mode, PPPoE in PPPoE mode, and default, tap0 or tun0 as appropriate after

the VPN is turned on.

5.4.7 Network ->VLAN&QoS

Sections	Description
VLAN	<p>VLAN settings.</p> <ul style="list-style-type: none"> LAN Port/PC Port: You can configure VLAN setting for both ports respectively. Active: To enable or disable VLAN feature for designated port. VID: To configure VLAN id for designated port. Priority: To select VLAN priority for designated port. DHCP Vlan: To enable or disable DHCP VLAN DHCP Option: To set DHCP Option. <p>Note: Please consult your administrator for specific VLAN settings in your networking environment.</p>
QoS	<p>QoS settings.</p> <ul style="list-style-type: none"> SIP QoS: To configure QoS value for all SIP message. Voice QoS: To configure QoS value for all audio stream (RTP streams).

5.4.8 Network ->802.1X

Sections	Description
802.1X	<p>It configures 802.1X feature.</p> <ul style="list-style-type: none"> 802.1X Mode: To enable or disable 802.1X. Provisioning Mode: Set provisioning mode when 802.1X Mode is EAP-FAST. Anonymous ID: Configure the anonymous ID used to hide the real 802.1X user. Identity: Configure the username used for 802.1X. Password: Configure the password used for 802.1X.
CA Certificate	Display or delete the CA certificate, which is used to verify the authenticity of the device certificate.
CA Certificate Upload	Upload the file that will be used as the CA certificate.

Sections	Description
Device Certificate	Display or delete the device certificate, which is used to verify the identity of the device with the 802.1X server.
Device Certificate Upload	Upload the file that will be used as the device certificate.

5.4.9 Network ->Diagnosis

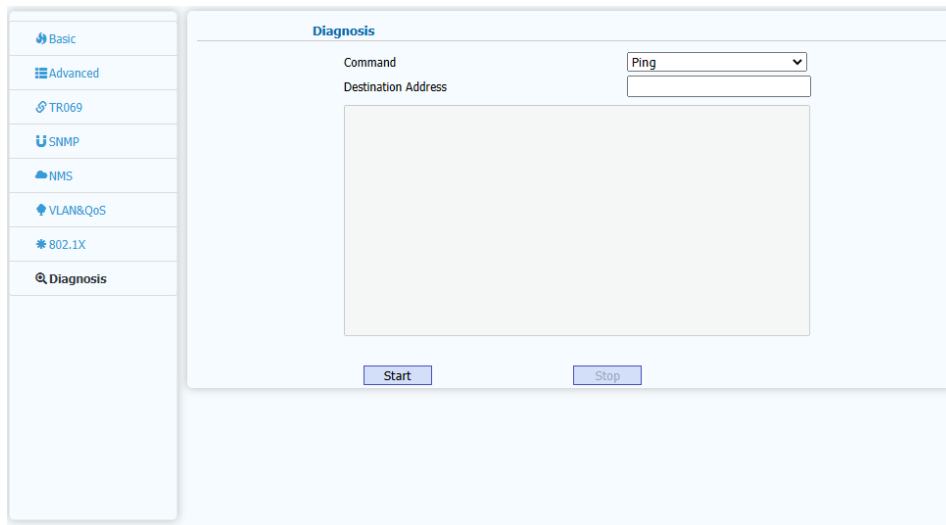

Sections	Description
Diagnosis	Used to detect network connectivity.

5.5 Phone

5.5.1 Phone->Basic

Sections	Description
LCD Language	choose the phone language.
Audio Mode	<ul style="list-style-type: none"> • Audio Device: Select audio device such as Speaker or Headset. • Ring From Headset: Enable or disable Ring from headset. • EHS Type: Set EHS Type including Disabled, Custom, JABRA, PLANTRONICS, SENNHEISER. • EHS Mic Impedance: Set EHS Mic Impedance.
Display	<ul style="list-style-type: none"> • Backlight Level: Adjust the backlight intensity of the phone interface. • Backlight Time: Adjust the backlight timer, once it expires, the backlight on the phone interface will dim. • Screensaver Time: Adjust the standby time of the screen saver on.
Notification Popups	<p>Notification Popups</p> <ul style="list-style-type: none"> • Enable/disable display voice mail popup. • Enable/disable display Txt message popup. • Enable/disable display missed call popup. • Enable/disable display forward call popup.

5.5.2 Phone->Time&Date

Sections	Description
Format Setting	<p>Time and date format settings.</p> <ul style="list-style-type: none"> Time Format: Determine what format to display on Phone UI (12 hour/24 hour). Date Format: Determine what format to display on Phone UI for Date. Display Mode: Determine what mode to display Time &Date on Phone UI.
Time & Date	<p>To select how to configure time, it could be set manually or Get from INTERNET automatically via NTP server.</p> <ul style="list-style-type: none"> Manual: To set Time and Date manually. <p>Note: If you set time to be Manually, it only takes effect till next reboot, after reboot, the phone will switch to Auto mode automatically, because there is no way for IP phone to record time during power off.</p> <ul style="list-style-type: none"> NTP: To get Time via NTP server. Time Zone: To select local Time Zone for NTP server. Primary Server: To configure primary NTP server address.

Sections	Description
	<ul style="list-style-type: none"> • Secondary Server: To configure secondary NTP server address, it takes effect if primary NTP server is unreachable. • Update Interval: To configure interval between two consecutive NTP requests. <p>Note: NTP, Network Time Protocol is used to automatically synchronized local time with INTERNET time, since NTP server only response GMT time, so that you need to specify the Time Zone for IP phone to decide the local time.</p>
Daylight Saving Time	<p>DST settings.</p> <p>Note: Here DST, is short for Daylight saving time, which stands for the time in the summer days when sun rises early will be adjusted forward to save daylight. The DST will take effects during the period that set by user. (All the settings for DST are all self-explanatory, please consult with your administrator for local DST details).</p>
Auto Reboot	<p>Set the phone's daily restart time.</p> <ul style="list-style-type: none"> • Active: Enabled/Disabled. • Reboot Interval: Set the number of days between scheduled reboot. • Reboot Time: Choose the time for the scheduled reboot. • Expect Reboot Time: View the estimated time of the next reboot.

5.5.3 Phone-> Call Feature

<ul style="list-style-type: none"> Basic Time&Date Call Feature Voice Key Ringtones Tones Dial Plan Action URL Multicast Forward&DND Intercom ACD Power LED 	<p>Dial</p> <p>Dial Timeout Enable: Disabled</p> <p>Dial Timeout: 4 (1~15s)</p> <p>Call Waiting</p> <p>Active: Enabled</p> <p>CallWaiting Tone: Enabled</p> <p>CallWaiting Response Code: 180</p> <p>Rejection Code When CW is Disabled: 486 (Busy Here)</p> <p>On Code: </p> <p>Off Code: </p> <p>Call Park</p> <p>Active: Enabled</p> <p>Call Park Code: </p> <p>Group Park Code: </p> <p>Auto Redial</p> <p>Auto Redial: Disabled</p> <p>Auto Redial Interval: 10 (1~300s)</p> <p>Auto Redial Times: 3 (1~100)</p> <p>BLF Pickup Alert</p> <p>BLF Pickup Alert: Disabled</p> <p>Remote Control</p> <p>Allowed Access IP List: </p> <p>Call Completion</p> <p>Call Completion: Disabled</p> <p>Others</p> <p>Reject Response Code: 486 (Busy Here)</p> <p>Auto Answer Delay: 0 (0~5s)</p> <p>Auto Hangup Time: 2 (1~30s)</p> <p>Early DTMF: Disabled</p> <p>Multicast Codec: PCMU</p> <p>Call Info Show Mode: Omitted Mode</p> <p>User Info Show Type: Name+Number</p> <p>Display The Active Account: Disabled</p> <p>Rtp Check Time: Disabled</p> <p>Outgoing Call Timeout: 60 (10~150s)</p> <p>Incoming Call Timeout: 65 (10~150s)</p>
----------------------------------------------------------------------------------------------------------------------------------------------------------------------------------------------------------------------------------------------------------------------------------------------------------------	----------------------------------------------------------------------------------------------------------------------------------------------------------------------------------------------------------------------------------------------------------------------------------------------------------------------------------------------------------------------------------------------------------------------------------------------------------------------------------------------------------------------------------------------------------------------------------------------------------------------------------------------------------------------------------------------------------------------------------------------------------------------------------------------------------------------------------------------------------------------------------------------------------------------------------------------------------------------------------------------------------------------------------------------------------------------------------------------------------------------------------------------------------------------------------------------------

Sections	Description
Dial	<p>It enables or disables Dial feature.</p> <ul style="list-style-type: none"> • Dial Timeout Enable: Enable or disable dial timeout. • Dial Timeout: Set Dial Timeout.
Call Waiting	<p>It enables or disables Call Waiting.</p> <ul style="list-style-type: none"> • Active: If enabled, it allows IP phones to receive a new incoming call when there is already an active call. • Call Waiting Tone: If enabled, it allows IP phones to play the call waiting tone to the waiting callee. • Call Waiting Response Code: Support 180 Response and 182 Response. • On Code: Set On Code. • Off Code: Set Off Code.
Call Park	<p>It enables or disables Call Park.</p>

Sections	Description
	<ul style="list-style-type: none"> • Active: To enable or disable call park feature. • Call Park Code: To set call park code. • Group Park Code: To set group park code.
Auto Redial	<p>Auto redial allows IP phones to redial an unsuccessful call for designated times within designated interval.</p> <ul style="list-style-type: none"> • Auto Redial: To enable or disable auto redial feature. • Auto Redial Interval: Determine the interval between two consecutive attempts. • Auto Redial Times: Determine how many times to redial.
BLF Pick Up Alert	<ul style="list-style-type: none"> • BLF Pickup Alert: To enable the BLF pick up function.
Remote Control	<p>Remote Control allows specific host to interact with IP phone by sending HTTP or HTTPS requests. The specific action could be answering an incoming call, hang up an ongoing call and so on.</p> <ul style="list-style-type: none"> • Allowed Access IP List: To configure the allowed host address. <p>Note: For now, IP phone can only support IP address, IP address list and IP address pattern as allowed hosts.</p>
Call Completion	<p>It enables or disables Call Completion.</p>
SIM Switch (Only for G100-V)	<ul style="list-style-type: none"> • SIM Auto Switch: To enable or disable SIM auto switch feature. • Switch Call Count: To configure the call count to automatically switch SIM cards. • Switch Call Time: To configure the call time to automatically switch SIM cards. <p>Note: When two SIM cards are inserted, you can manually switch SIM cards by pressing the left or right key of the navigation Keys.</p>
Others	<ul style="list-style-type: none"> • Reject Response Code: Allows user to assign specific code as return code to SIP server when an incoming call is rejected. • Auto Answer Delay: To configure delay time before an incoming call is automatically answered. • Auto Hang up Time: To configure the time from the busy

Sections	Description
	<p>tone to the standby state after the other party hangs up.</p> <ul style="list-style-type: none"> • Early DTMF: To enable or disable early DTMF. • Multicast codec: To choose different multicast codec. • Call Info Show Mode: supports omitted mode and rolling mode • User Info Show Type: Select different Caller Display Types • Display The Active Account: enable/disable • Rtp Check Time: Set RTP Check Time • Outgoing Call Timeout: set maximum wait time for outgoing calls (seconds) • Incoming Call Timeout: set maximum ring time for incoming calls (seconds) • VoLTE call mode (only for G100-V) <p>Local mode: when enabled, Account 2 can make calls directly via the 4G module.</p> <p>SIP mode: when enabled, Account 1 and Account 2 must register to the server. The server must be configured with routing between Account 1 and Account 2. For outgoing calls, Account 1 dials the phone number, and the server forwards it via the configured route to Account 2, which then places the call through the 4G module.</p> <p>Server routing configuration reference:</p> <p>For example, if Account 1 is 1010 and Account 2 is 1011, configure:</p> <ul style="list-style-type: none"> ✧ Route 1: forward messages with source address from 1010 to 1011 ✧ Route 2: forward messages with source address from 1011 to 1010

5.5.4 Phone->Voice

<ul style="list-style-type: none"> Basic Time&Date Call Feature Voice Key Ringtones Tones Dial Plan Action URL Multicast Forward&DND Intercom ACD Power LED 	<p>Echo Canceller</p> <p>Echo Canceller <input type="text" value="Enabled"/></p> <p>VAD <input type="text" value="Disabled"/></p> <p>CNG <input type="text" value="Disabled"/></p> <p>Jitter Buffer</p> <p>Jitter Type <input type="text" value="Adaptive"/></p> <p>Min Delay <input type="text" value="0"/> (0~200ms)</p> <p>Normal Delay <input type="text" value="120"/> (0~200ms)</p> <p>Max Delay <input type="text" value="200"/> (0~200ms)</p> <p>Talk Volume</p> <p>Handset Volume <input type="text" value="6"/> (1~10)</p> <p>Headset Volume <input type="text" value="6"/> (1~10)</p> <p>Handoff Volume <input type="text" value="3"/> (1~10)</p> <p>Tone Volume</p> <p>Handset Volume <input type="text" value="5"/> (1~10)</p> <p>Headset Volume <input type="text" value="5"/> (1~10)</p> <p>Handoff Volume <input type="text" value="5"/> (1~10)</p> <p>Mic Volume</p> <p>Handset Volume <input type="text" value="5"/> (1~10)</p> <p>Headset Volume <input type="text" value="5"/> (1~10)</p> <p>Handsfree Volume <input type="text" value="5"/> (1~10)</p> <p>Key Volume</p> <p>Volume <input type="text" value="5"/> (0~10)</p> <p>Ring Volume</p> <p>Volume <input type="text" value="6"/> (0~10)</p>
----------------------------------------------------------------------------------------------------------------------------------------------------------------------------------------------------------------------------------------------------------------------------------------------------------------	---------------------------------------------------------------------------------------------------------------------------------------------------------------------------------------------------------------------------------------------------------------------------------------------------------------------------------------------------------------------------------------------------------------------------------------------------------------------------------------------------------------------------------------------------------------------------------------------------------------------------------------------------------------------------------------------------------------------------------------------------------------------------------------------------------------------------------------------------------------------------------------------------------------------------------------------------------------------------------------------------------------------------------------------------------------------------------------------------------------------------------------------------------------------------------------------------------------------------------------------------------------------------

Sections	Description
Echo Canceller	<ul style="list-style-type: none"> • Echo Canceller: To remove acoustic echo from a voice communication in order to improve the voice quality. • VAD (Voice Activity Detection): Allow IP phone to detect the presence or absence of human speech during a call. When detecting period of “silence”, VAD replaces that silence efficiently with special packets that indicate silence is occurring. It can facilitate speech processing, and deactivate some processes during non-speech section of an audio session. It can avoid unnecessary coding or transmission of silence packets in VoIP applications, saving on computation and network bandwidth. • CNG (Comfort Noise Generation): Allow IP phone to generate comfortable background noise for voice communications during periods of silence in a conversation. It is a part of the silence suppression or VAD handling for VoIP technology. CNG, in conjunction with VAD algorithms, quickly responds when periods of silence occur and inserts artificial noise until voice activity resumes. The insertion of artificial noise gives the illusion of a constant transmission stream, so that background sound is consistent throughout the call and the listener

Sections	Description
	does not think the line has released.
Jitter Buffer	<p>Jitter buffer is a shared data area where voice packets can be collected, stored, and sent to the voice processor in even intervals. Jitter is a term indicating variations in packet arrival time, which can occur because of network congestion, timing drift or route changes. The jitter buffer, located at the receiving end of the voice connection, intentionally delays the arriving packets so that the end user experiences a clear connection with very little sound distortion. IP phones support two types of jitter buffers: fixed and adaptive.</p> <ul style="list-style-type: none"> • Fixed: Add the fixed delay to voice packets. You can configure the delay time for the static jitter buffer on IP phones. • Adaptive: Capable of adapting the changes in the network's delay. The range of the delay time for the dynamic jitter buffer added to packets can be also configured on IP phones. • Min Delay: Set the minimum delay time. • Normal Delay: Set normal delay time • Max Delay: Set the maximum delay time
Talk Volume	Set the talk volume.
Tone Volume	Set the tone volume.
Mic Volume	Adjust microphone volume for headset, handset and speaker mode.
Key Volume	Set the key volume.
Ring Volume	Set the ring volume.

5.5.5 Phone->Key

- Basic
- Time&Date
- Call Feature
- Voice
- Key**
- Ringtones
- Tones
- Dial Plan
- Action URL
- Multicast
- Forward&DND
- Intercom
- ACD
- Power LED

Line Key

Key	Type	Label	Value	Account	Extension
Line Key 1	BLF/NewCall	8003	8003	Account 2	8003
Line Key 2	Account			Account 1	

Soft Key

Key	Type	Label	Value	Account
Soft Key 1	History			Auto
Soft Key 2	Callback			Auto
Soft Key 3	DND			Auto
Soft Key 4	Menu			Auto

Function Key

Key	Type	Value	Account
OK	Status		Auto
Cancel	N/A		Auto
Mute	N/A		Auto

Keypad Lock

Keypad Lock Type:

Keypad Unlock PIN: (1~15)

Keypad Lock Timeout: (1~3600s)

Emergency Call:

Key As Send

Key As Send:

Send # when First Dial Number is *:

Others

Redial Function:

Line Key Font Size:

Sections	Description
Line Key	<p>Allows user to assign specific feature to the designated line key. For line key, the available feature list:</p> <p>N/A, DND, Menu, SMS, Status, Book, Fwd(Forward), Pick Up, Group Pick Up, Intercom, Speed Dial, History, Favorites, Redial, Account, ACD, BLF/NewCall, BLF/BXFER, BLF/AXFER, BLF List, Callback, Hot Desking, Record, XML Browser, DTMF, Multicast Paging, Voice Message, Transfer, Call Park, XML History, XML Phone Book, Prefix, Visual Park.</p>
Soft Key	<p>Allows user to assign specific feature to the designated soft keys. For soft key, the following is the available features:</p> <p>DND, Menu, SMS, Status, Book, Fwd(Forward), Pick Up, Group Pick Up, Intercom, Speed Dial, History, Favorites, Redial, Callback, Hot Desking, XML Browser, Simple Menu, Voice Message, XML History, XML Phone Book, ACD.</p>
Function Key	<p>Allows user to assign specific feature to the designated function keys. For function keys, the available features are as follows:</p> <p>DND, Menu, SMS, Status, Book, Fwd(Forward), Pick Up, Group Pick Up, Intercom, Speed Dial, History, Favorites, Redial, Callback, Hot Desking, XML Browser, Voice Message, Transfer, XML History, XML Phone Book.</p>
Keypad Lock	<p>Keypad lock can temporarily lock the phone keypad when not in use. This feature helps prevent unauthorized use of the phone.</p>

Sections	Description
	<ul style="list-style-type: none"> Keypad Lock Type: Choose to lock function keys or all keys. Keypad Unlock PIN: The password for lock. Keypad Lock Timeout: The idle interval for locking the phone. Emergency Call: Set Emergency call
Key As Send	" Key As Send " allow you to disable the send key or assign the # key and * key as the send key.
Others	<ul style="list-style-type: none"> Redial Function: optional direct call or enter dialed history. Line Key Font Size: optional normal or small.

5.5.6 Phone->Ringtones

Sections	Description
Ringtones	<p>Allows user to upload and view ringtone files or delete uploaded ringtone files.</p> <ul style="list-style-type: none"> Upload (max upload size: 100k): Upload ringtone files. Uploaded ringtones: Ringtones that have been uploaded. Ringtone settings: Selectable ringtones. <p>Note: Ringtone files are suggested to be (8K 8bit U-law) .wav format files, please contact technical support team for</p>

Sections	Description
	instructions how to make ringtone files. system ringtone files cannot be deleted thus user can only delete uploaded ringtone.
Distinctive Ringers	Distinctive ringers allow different incoming calls to trigger distinctive ringtone. The IP phone will check “Alert-Info” header inside the incoming “invite” SIP message. And strip out the URL or keyword inside the “Alert-Info” header, from the specific URL or keyword to match or download designated ringtone to play.

5.5.7 Phone->Tones

Tones

Select Country or Region	Default ▾
Busy Tone	480+620/500,0/500
RingBack Tone	440+480/2000,0/4000
Dial Tone	350+440

Sections	Description
Tones	<p>Allows users to select tones (classified by country or region) or customize tones.</p> <ul style="list-style-type: none"> Select country or region: choose the appropriate country or region; Busy tone: busy tone value; Ringback tone: ringback tone value; Dial tone: dial tone value. <p>Note: Optional country/region tone sets include: China, Spain, Luxembourg, Sweden, Taiwan (China), Belgium, Denmark, France, Germany, Netherlands, Norway, Portugal, Italy, United States, Austria, France, Greece, Japan, United Kingdom, Australia, Hong Kong (China), Russia, Poland, Turkey, Bosnia, North Korea.</p>

5.5.8 Phone ->Dial Plan

a) Dial Plan-Replace Rule

Sections	Description
Rules	Allows user to select Replace rule or Dial-now to display or edit. For replace rules, you can add, modify, or delete prefix for accounts.
Area Code	Area codes are also known as NPAs (Numbering Plan Areas). They usually indicate different geographical areas within one country. If entered numbers match the predefined area code rule, the IP phone will automatically prefix outgoing number with area code. Note: There is only one area code rule supported.

b) Dial Plan-Dial Now

Sections	Description
Rules	Allows user to select Replace rule or Dial-now to display or edit. For Dial Now, you can add, modify, or delete prefix for accounts.
Area Code	Area codes are also known as NPAs (Numbering Plan Areas). They usually indicate different geographical areas within one country. If entered numbers match the predefined area code rule, the IP phone will automatically prefix outgoing number with area code. Note: There is only one area code rule supported.

5.5.9 Phone->Action URL

Sections	Description
Action URL	Action URL settings.

Sections	Description
	<ul style="list-style-type: none"> • Active: Enable or disable Action URL. • Setup Completed: When the IP phone completes startup. • Registered: When the IP phone successfully registers an account. • Unregistered: When the IP phone logs off the registered account. • Register Failed: When the IP phone fails to register an account. • Off Hook: When the IP phone is off hook. • On Hook: When the IP phone is on hook. • Incoming Call: When the IP phone receives an incoming call. • Outgoing Call: When the IP phone places a call. • Established: When the IP phone establishes a call. • Terminated: When the IP phone terminates a call. • Open DND: When the IP phone enables the DND mode. • Close DND: When the IP phone disables the DND mode. • Open Always FWD: When the IP phone enables the always forward. • Close Always FWD: When the IP phone disables the always forward. • Open Busy FWD: When the IP phone enables the busy forward. • Close Busy FWD: When the IP phone disables the busy forward. • Open No Answer FWD: When the IP phone enables the no answer forward. • Close No Answer FWD: When the IP phone disables the no answer forward. • Transfer Call: When the IP phone transfers a call. • Blind Transfer: When the IP phone blind transfers a call. • Attended Transfer: When the IP phone performs the semi-attended/attended transfer.

Sections	Description
	<ul style="list-style-type: none"> • Hold: When the IP phone places a call on hold. • UnHold: When the IP phone retrieves a hold call. • Mute: When the IP phone mutes a call. • UnMute: When the IP phone un-mutes a call. • Missed Call: When the IP phone misses a call. • IP Changed: When the IP address of the IP phone changes. • FWD Incoming Call: When the IP phone forwards an incoming call. • Reject Incoming Call: When the IP phone rejects an incoming call. • Answer New Call: When the IP phone answers a new call. • Transfer Finished: When the IP phone completes to transfer a call. • Transfer Failed: When the IP phone fails to transfer a call. • Idle To Busy: When the state of the IP phone changes from idle to busy. • Busy To Idle: When the state of phone changes from busy to idle.

5.5.10 Phone ->Multicast

Sections	Description
Multicast Setting	Multicast setting.

	<ul style="list-style-type: none"> • Paging Barge: Choose the multicast number, the range is 1-10. • Paging priority Active: Enable or disable the multicast.
Priority List	<p>It configures the multicast parameters.</p> <ul style="list-style-type: none"> • Listening Address: Enter the IP address you need to listen. • Label: Input the label for each listening address.

5.5.11 Phone->Forward & DND

- Basic
- Time&Date
- Call Feature
- Voice
- Key
- Ringtones
- Tones
- Dial Plan
- Action URL
- Multicast
- Forward&DND**
- Intercom
- ACD
- Power LED

Sync Feature Code

Active: Disabled

Mode: Phone Custom

Forward Transfer

Account: All Account

Always Forward: Disabled

Target Number:

On Code:

Off Code:

Busy Forward: Disabled

Target Number:

On Code:

Off Code:

No Answer Forward: Disabled

No Answer Ring Time: 30

Target Number:

On Code:

Off Code:

DND

Account: All Account

DND: Disabled

Return Code When DND: 486 (Busy Here)

DND On Code:

DND Off Code:

DND Timer Enable: Disabled

DND Timer 1: 0 Hour 0 Min -- 23 Hour 59 Min

DND Timer 2: 0 Hour 0 Min -- 23 Hour 59 Min

DND Timer 3: 0 Hour 0 Min -- 23 Hour 59 Min

Sections	Description
Sync Feature Code	<ul style="list-style-type: none"> • Active: enable or disable function synchronization. • Mode: select the desired mode.
Forward Transfer	<p>Forward settings:</p> <p>Note: There are three types of forwarding: Always Forward, Busy Forward, and No Answer Forward.</p> <ul style="list-style-type: none"> • Account: Select the account that needs to enable forwarding. • Always Forward: calls will be forwarded under any circumstances. • Target Number: Set the always forward target number; • On Code: After setting the On Code, the user can dial the On Code + target number to enable always forward; • Off Code: After setting the Off Code, the user can dial the Off Code + target number to disable the always forward; • Busy Forward: if the IP phone is busy, the call will be forwarded. • Target Number: Set the busy forward target number; • On Code: After setting the On Code, the user can dial the On Code + target number to enable busy forward; • Off Code: After setting the Off Code, the user can dial the Off Code + target number to disable the busy forward; • No Answer Forward: If no one answers after a certain time, the call will be forwarded. • No Answer Ring Time: Set the no answer ring time, if no one answers within the set time, the call will be forwarded; • Target Number: Set the no answer forward target number; • On Code: After setting the On Code, the user can dial the On Code + target number to enable no answer

Sections	Description
	<p>forward;</p> <ul style="list-style-type: none"> • Off Code: After setting the Off Code, the user can dial the Off Code + target number to disable the no answer forward;
DND	<p>Do not disturb allows the IP phone to ignore any incoming call:</p> <ul style="list-style-type: none"> • Account: Select the account that needs to enable the DND function. • DND: Enable or disable DND. • Return Code When DND: Determine what response code should be sent back to the server when do not disturb is turned on and there is an incoming call. • DND On Code: The code used to turn on DND on the server (if configured), if you press DND when the DND is off, the IP phone will send a SIP message to the server to turn on DND on the server. • DND Off Code: The code used to turn off DND on the server (if configured), if you press DND when it is turned on, the IP phone will send a SIP message to the server to turn off DND on the server. • DND Timer Enable: Enable or disable DND timer. The DND timer can make DND take effect in a specified time period. <p>Note: The DND timer can only be enabled when DND is turned on.</p>

5.5.12 Phone->Intercom

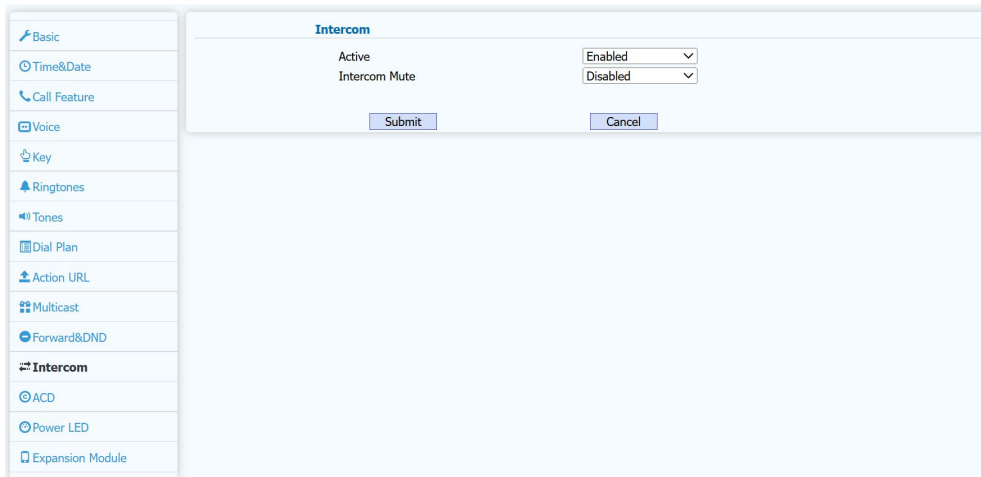

Sections	Description
Intercom	<p>Intercom allows users to directly calls with the other party:</p> <ul style="list-style-type: none"> Active: Enable or disable the intercom function. Intercom Mute: After enabling, once a call is established, the phone will be muted by default.

5.5.13 Phone->ACD

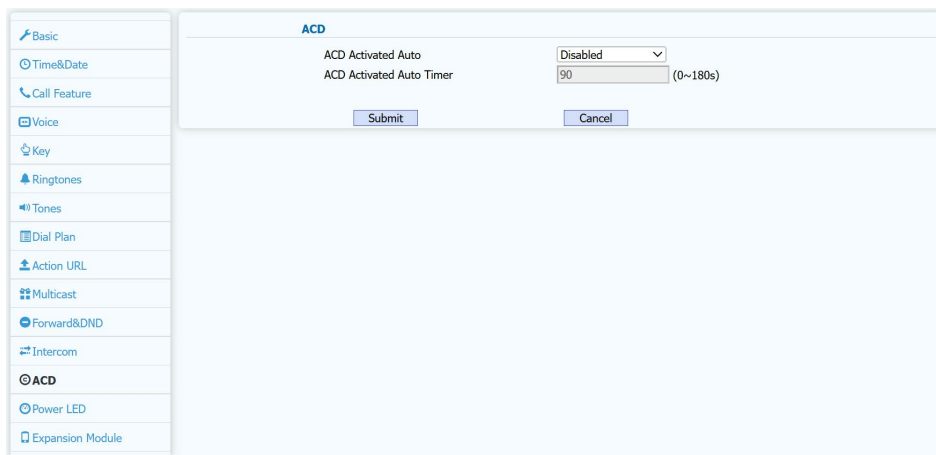

Sections	Description
ACD	<p>ACD (Automatic Call Distribution) is the most common used in the call center. It allows IP phones to log in to the system in multiple states so that the system can distribute incoming calls to available users or agents.</p> <ul style="list-style-type: none"> ACD Activated Auto: If activated, the phone will automatically

	<p>become available within a specified time (determined by the ACD automatic activation time).</p> <ul style="list-style-type: none"> • ACD Activated Auto Timer: Configure the time interval for the phone to automatically become available.
--	---------------------------------------------------------------------------------------------------------------------------------------------------------------------------------------------------------------------------------------------------------------

5.5.14 Phone->Power LED

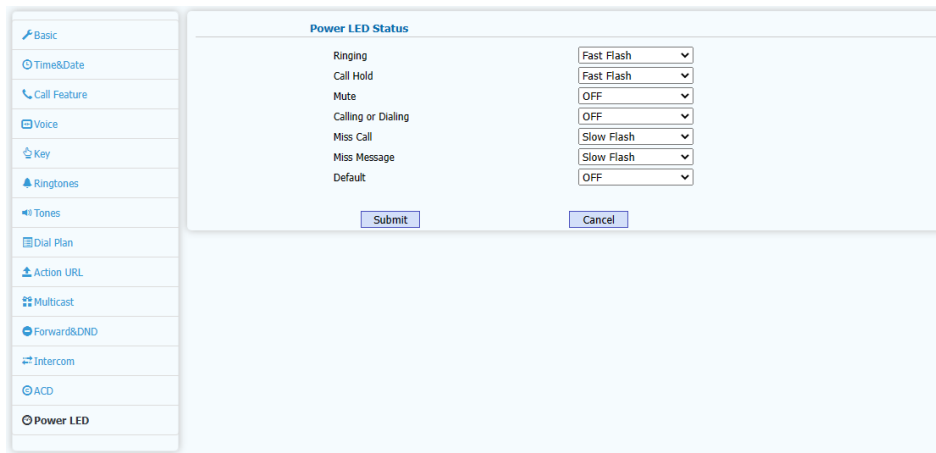

Sections	Description
Power LED Status	<p>Power LED Status is used to set the status of the device's power indicator in different scenarios.</p> <ul style="list-style-type: none"> • Ringing: Set the status of the power indicator when IP Phone is ringing. • Call Hold: Set the status of the power indicator when the call is on hold. • Mute: Set the status of the power indicator when the phone is on mute. • Calling or Dialing: Set the status of the power indicator when the phone is calling or dialing. • Miss Call: Set the status of the power indicator when the call is missed. • Miss Message: Set the status of the power indicator when the message is missed. • Default: Set the status of the power indicator when the phone is standby.

5.6 Phone Book

5.6.1 Phone Book -> Local Book

The screenshot displays the 'Local Book' management interface. On the left is a navigation menu with options: Local Book, Remote Book, Call History, LDAP, Broadsoft, and Enterprise Directory. The main area is divided into several sections:

- Contact:** Includes a dropdown for 'All Contacts', search and reset buttons, a dial input field with an 'Auto' dropdown, 'Dial' and 'Hand Up' buttons, a 'Name' sort dropdown, and a 'Rejection Code for Restricted Call' dropdown set to '603 (Decline)'.
- Contact List:** A table with columns: Index, Name, Office Number, Mobile Number, Other Number, Group, Ring, Account, and a checkbox. It shows 10 empty rows.
- Contact Setting:** Fields for Name, Office Number, Mobile Number, Group (Default), Other Number, and Ring (Auto), with 'Add', 'Edit', and 'Cancel' buttons.
- Group List:** A table with columns: Index, Name, Ring, Description, and a checkbox. It shows 10 empty rows.
- Group Setting:** Fields for Name, Ring (Auto), and Description, with 'Add', 'Edit', and 'Cancel' buttons.
- Import/Export:** 'Add', 'Edit', and 'Cancel' buttons.
- Export Format:** A dropdown menu set to '.XML'.
- Contact, Black List, White List:** Each has a 'Browse' button, a 'not selected' status, and a file type '(.XML/.CSV/.VCF)'. Each also has 'Import', 'Export', and 'Cancel' buttons.

Sections	Description
Contact	To select the type for local book. <ul style="list-style-type: none"> • All Contacts: To display or edit all local contacts. • Favorites: To display or edit favorites contacts. • Black List: To display black list contacts. • White List: To display white list contacts.
Search	To search designated contacts from local phonebook.

Sections	Description
Dial	Dial out a call or hang up an ongoing call from Web UI. Note: For this feature, you need to have the remote control privilege to control IP phone via Web UI. Please refer to section “Remote Control” in the Web UI-> Phone -> Call Feature page.
Sort	To configure the sorting method for the local book. The Index and name are optional.
Contact Setting	Management contacts.
Group Setting	Management group contacts.
Import/Export	Import or export the contact or blacklist file.

5.6.2 Phone Book -> Remote Book

The screenshot shows the 'Remote Book' configuration page. On the left is a navigation menu with options: Local Book, Remote Book (selected), Call History, LDAP, Broadsoft, and Enterprise Directory. The main content area is titled 'Remote Book' and contains a table with the following structure:

Index	Remote URL	Display Name
1		
2		
3		
4		
5		

Below the table, there are two configuration fields:

- Search Remote Phonebook Name: A dropdown menu currently set to 'Enabled'.
- Refresh Interval: A text input field containing '3600', with a range '(120~2592000s)' indicated to the right.

At the bottom of the configuration area are 'Submit' and 'Cancel' buttons.

Sections	Description
Remote Book	<p>Remote Book settings.</p> <ul style="list-style-type: none"> • Index: To select desired Remote Book item to display and configure. • Remote URL: To configure remote book server address. • Display Name: To configure display remote book name on Phone UI. • Search Remote Phonebook Name: To enable or disable search remote phonebook name. • Refresh Interval: To set interval (Range from 120s to 2592000s). <p>Note: IP phone supports at most 5 remote books. Please refer to your administrator for how to establish a remote book server and</p>

how to create remote book xml file.

5.6.3 Phone Book -> Call History

- Local Book
- Remote Book
- Call History**
- LDAP
- Broadsoft
- Enterprise Directory

Direct Call By History Enabled

More Info On History Call Duration

History Max Num 100

History Clear Time Keep History

Call History All

[Hand Up](#)

In dex	Type	Time	Local Identity	Name	Number	Call Durati on	Accou nt	RTP Send	RTP Recv	Lost (%)	Jitt er (m s)	Del ay (m s)	
1	Receive d	2025-12-19 11:22:52	8003	8801	8801@172.27.10.23	00:00:07	1	0	0	0	0	0	<input type="checkbox"/>
2	Dialed	2025-12-19 11:22:57	8003	8002	8002@172.27.10.23	00:00:00	1	0	0	0	0	0	<input type="checkbox"/>
3	Receive d	2025-12-19 11:20:26	8003	8801	8801@172.27.10.23	00:00:07	1	0	0	0	0	0	<input type="checkbox"/>
4	Dialed	2025-12-19 11:20:32	8003	8002	8002@172.27.10.23	00:00:00	1	0	0	0	0	0	<input type="checkbox"/>
5	Receive d	2025-12-19 11:19:23	8003	8801	8801@172.27.10.23	00:00:10	1	0	0	0	0	0	<input type="checkbox"/>
4	Dialed	2025-12-19 11:20:32	8003	8002	8002@172.27.10.23	00:00:00	1	0	0	0	0	0	<input type="checkbox"/>
7	Receive d	2025-12-19 11:19:07	8003	8801	8801@172.27.10.23	00:00:10	1	0	0	0	0	0	<input type="checkbox"/>
8	Receive d	2025-12-19 10:51:27	8003	8801	8801@172.27.10.23	00:00:28	1	0	0	0	0	0	<input type="checkbox"/>
9	Dialed	2025-12-19 10:51:52	8003	8002	8002@172.27.10.23	00:00:00	1	0	0	0	0	0	<input type="checkbox"/>
10	Dialed	2025-12-19 10:51:36	8003	8003	8003@172.27.10.23	00:00:00	1	0	0	0	0	0	<input type="checkbox"/>
11	Receive d	2025-12-19 10:51:36	8003	8003	8003@172.27.10.23	00:00:00	1	0	0	0	0	0	<input type="checkbox"/>
12	Receive d	2025-12-19 10:50:23	8003	8801	8801@172.27.10.23	00:00:08	1	0	0	0	0	0	<input type="checkbox"/>
13	Dialed	2025-12-19 10:50:29	8003	8002	8002@172.27.10.23	00:00:00	1	0	0	0	0	0	<input type="checkbox"/>
14	Receive d	2025-12-19 10:49:35	8003	8801	8801@172.27.10.23	00:00:11	1	0	0	0	0	0	<input type="checkbox"/>
15	Dialed	2025-12-19 10:49:40	8003	8002	8002@172.27.10.23	00:00:00	1	0	0	0	0	0	<input type="checkbox"/>

Page 1 Prev Next Delete Delete All

Sections	Description
Call History	<p>Available call history types are All calls, dialed calls, received calls, missed calls, forwarded calls.</p> <ul style="list-style-type: none"> Direct Call By History: Enable or disable Direct Call By History More Info On History: You can choose time or call duration. History Max Num: Set the maximum number of call history entries to display (0–1000) History Clear Time: Set the time to clear call history; default is no auto-clear Call History: Include received, dialed, missed, forwarded and all call history logs Hang Up: To click to hang up ongoing call on the IP phone. <p>Note: For “Hang Up” feature, you need to have the remote control privilege to control IP phone via Web UI. Please refer to section “Remote Control” in the Web UI -> Phone -> Call</p>

Sections	Description
	Feature page.

5.6.4 Phone Book -> LDAP

Sections	Description
LDAP	<p>LDAP phonebook settings.</p> <ul style="list-style-type: none"> Name Filter: The settings used to tell LDAP server what name attributes to search. Number Filter: The settings used to tell LDAP server what number attributes to search. Encryption Mode: <ul style="list-style-type: none"> NULL: It is not encrypted. StartTLS: It is not encrypted at first, and can be switched to TLS encryption mode after negotiation. TLS: Transport Layer Security (TLS) is an encryption protocol that provides communication security over computer networks. Server: To configure LDAP server's address. Port: To configure LDAP server's port. Base: To configure searching base DN on LDAP server. User Name: To configure user name for accessing LDAP

Sections	Description
	<p>server.</p> <ul style="list-style-type: none"> • Password: To configure password for accessing LDAP server. • Protocol: Specify the LDAP protocol version to use when communicating with the directory server. • Name Attribute: To configure which name attributes should be feedback from LDAP server. • Number Attribute: To configure which number attributes should be feedback from LDAP server. • Display Name: To configure display name on Phone UI when there is any searching result from LDAP server. • Max Hits: To configure the maximum size of result response from LDAP server. • Search Delay Time: To configure delay time before initiate LDAP searching request after you input a value from Phone UI. <p>Set LDAP phone book level display</p> <ul style="list-style-type: none"> • Lookup for Incoming Call: If enabled, the incoming call will be matched with the LDAP phone book and displayed. • Lookup for Dial: If enabled, it will be matched with the LDAP phonebook and displayed when calling out or replaying. • Hierarchy View: If enabled, the LDAP phone book will display hierarchical directories, such as multiple departments of a company. <p>Note: For setting details, please consult with your system administrator for further information.</p>

5.6.5 Phone Book -> Broadsoft

Sections	Description
Broadsoft PhoneBook	<p>Broadsoft PhoneBook settings.</p> <ul style="list-style-type: none"> • PhoneBook Item: To select specific item to configure. • Display Name: The name displayed at IP phone's LCD screen when accessed via Phone UI. • Server Address: Broadsoft PhoneBook server's address. • Server Port: Broadsoft PhoneBook server's port. • User Name: Username used to access Broadsoft PhoneBook server. • Password: Password used to access Broadsoft PhoneBook server. <p>Note: IP phone supports at most 5 Broadsoft PhoneBook items. For Broadsoft PhoneBook's server address, port, username and password, you need to consult your Broadsoft service provider for further information.</p>

5.6.6 Phone Book -> Enterprise Directory

Sections	Description
Enterprise Directory	<p>Enterprise directory settings.</p> <ul style="list-style-type: none"> • Active: Enable or disable enterprise directory. • Server Address: Set IP address of enterprise directory server. • User Name: Set user name. • Password: Set password. • Max Hits: Set max hits. • Search Delay Time: Set search delay time.

5.7 Maintain

5.7.1 Maintain->Upgrade

<ul style="list-style-type: none"> Upgrade Auto Provision System log PCAP Configuration PnP Custom language QoS 	<p>Firmware Version: 2.100.11.13.0</p> <p>Hardware Version: 100.2.1.0.2.1.6.0</p> <p>Type: Firmware</p> <p>Upgrade: <input type="button" value="Browse"/> not selected</p> <p><input type="button" value="Submit"/> <input type="button" value="Cancel"/></p> <p>Reset To Factory Setting: <input type="button" value="Submit"/></p> <p>Reboot: <input type="button" value="Submit"/></p>
-----------------------------------------------------------------------------------------------------------------------------------------------------------------------------------------------	-------------------------------------------------------------------------------------------------------------------------------------------------------------------------------------------------------------------------------------------------------------------------------------------------------------------------------------------------------------------------------------------

Sections	Description
Firmware Version	Show you the firmware version.
Hardware Version	Show you the hardware version.
Upgrade	To select upgrading rom file from local or a remote server automatically. Note: Please make sure it's right file format for right model.
Reset to Factory Setting	Allow you to reset IP phone's setting to factory settings.
Reboot	To reboot IP phone remotely from Web UI.

5.7.2 Maintain->Auto Provision

<ul style="list-style-type: none"> Upgrade Auto Provision System log PCAP Configuration PnP Custom language 	<p>DHCP Option</p> <p>DHCP Option 66: Enabled</p> <p>DHCP Option 43: Enabled</p> <p>Custom Option: (128~254)</p> <p>Provisioning Server</p> <p>URL: <input type="text"/></p> <p>Username: <input type="text"/></p> <p>Password: <input type="password"/></p> <p>Common AES Key: <input type="password"/></p> <p>AES Key(MAC): <input type="password"/></p> <p>Auto Provision</p> <p>Mode: Power On</p> <p>Schedule: Sunday</p> <p>Time: 22 Hour 0 Min</p> <p>Periodic Interval: 60 Min(5~1440)</p> <p>Idle Check Time: 0 Min(0~60)</p> <p>Clear MD5: <input type="button" value="Submit"/></p> <p>Export Configuration Template: <input type="button" value="Export"/></p> <p>Auto Provision Now</p> <p><input type="button" value="Auto Provision Now"/></p> <p><input type="button" value="Submit"/> <input type="button" value="Cancel"/></p>
----------------------------------------------------------------------------------------------------------------------------------------------------------------------------------	------------------------------------------------------------------------------------------------------------------------------------------------------------------------------------------------------------------------------------------------------------------------------------------------------------------------------------------------------------------------------------------------------------------------------------------------------------------------------------------------------------------------------------------------------------------------------------------------------------------------------------------------------------------------------------------------------------------------------------------------------------------------------------------------------------------------------------------------------------------------------

Sections	Description
DHCP Option	<p>It displays and configures DHCP option.</p> <ul style="list-style-type: none"> • DHCP Option 66: To enable or disable DHCP Option 66. • DHCP Option 43: To enable or disable DHCP Option 43. • Custom Option: If configured, IP Phone will use designated DHCP option to get Auto Provisioning server's address via DHCP. This setting requires DHCP server to support corresponding option.
Provisioning Server	<p>Update server settings.</p> <ul style="list-style-type: none"> • URL: Auto provisioning server address. • User name: Configure if server needs a username to access, otherwise left blank. • Password: Configure if server needs a password to access, otherwise left blank. • Common AES Key: Used for IP phone to decipher common Auto Provisioning configuration file. • AES Key (MAC): Used for IP phone to decipher MAC-oriented auto provisioning configuration file (for example, file name could be 0c1105888888.conf if IP phone's MAC address is 0c1105888888). <p>Note: AES is one of methods for encryption, it should be configured only configure file is ciphered with AES, otherwise left blank.</p>
Auto Provision	<p>Auto Provisioning mode settings.</p> <p>This Auto Provisioning mode is actual self-explanatory. For example, mode “Power on” means IP phone will go to do Provisioning every time it powers on.</p> <ul style="list-style-type: none"> • Schedule: Set automatic update time. • Time: Set automatic update time. • Periodic Interval: Set automatic update periodic interval. • Idle Check Time: Set automatic update idle check time. • Clear MD5: Used to clear MD5 of configuration file • Export Configuration Template: Export Auto Provisioning configuration template file.

Sections	Description
Auto Provision Now	Auto upgrade now.

5.7.3 Maintain->System Log

Sections	Description
System Log	<p>To display system log level and export log.</p> <ul style="list-style-type: none"> Log Level: From level 0~7. The higher level means the more specific syslog is saved to a temporary file. By default, it's level 3. Export Log: Click to export temporary syslog file to local PC. Remote Syslog: To enable or disable Remote System Log. Remote Syslog Server: To input the syslog server address. Backup Log: To enable or disable log backup.
Screenshot	Phone Screen: To capture and save the phone screen

5.7.4 Maintain->PCAP

Sections	Description
Network Capture	<p>Network packet capture settings and export data packet:</p> <ul style="list-style-type: none"> Interface: select the interface for network packet capture

Sections	Description
	<p>(LAN/Wi-Fi/4G/VPN/PPPoE).</p> <ul style="list-style-type: none"> Start: To start capturing all the packets file sent or received from IP phone. Stop: To stop capturing packets. <p>Note: IP phone will save captured packets file to a temporary file, this file maximum size is 1M (megabytes), and will top capturing once reaching this maximum size.</p>
Mirror	<p>Network port mirror settings:</p> <ul style="list-style-type: none"> Ethernet Port Mirror: If enabled, the PC port can mirror the packets of the Ethernet port.

5.7.5 Maintain->Configuration

Sections	Description
Configuration	Export or import the configuration file of the IP phone

5.7.6 Maintain->PnP

Sections	Description
PnP	<p>PnP setting for Auto Provisioning.</p> <ul style="list-style-type: none"> Active: Once PNP is enabled, the phone will send SIP subscription message to PNP server automatically to get Auto

Sections	Description
	<p>Provisioning server's address. By default, this SIP message is sent to multicast address 224.0.1.75.</p> <ul style="list-style-type: none"> • Server Address: The address of the PNP server. • Server Port: The port of the PNP server. • Update Interval: Check whether the PNP server has an update interval.

5.7.7 Maintain->Custom Language

Sections	Description
Resource Files	<ul style="list-style-type: none"> • Web: Upload and set Web language other than help information. • Web Help: Upload and set Web help information language. • LCD: Upload and set the system language of the phone.

5.8 Security

5.8.1 Security->Basic

Sections	Description
Web Password Modify	<p>To modify Web password.</p> <ul style="list-style-type: none"> • User Name: Select the username (administrator or user)

Sections	Description
	<p>that needs to be modified.</p> <ul style="list-style-type: none"> • Current Password: The current password you used. • New Password: Input new password you intend to use. • Confirm Password: Repeat the new password. • Sync Advanced Settings Password: Enable or disable syncing the login password as the phone interface's advanced settings access password.
Session Timeout	<p>It configures session timeout.</p> <ul style="list-style-type: none"> • Session Timeout: The value specifies the timeout for login retry in seconds.

5.8.2 Security->Advanced

Sections	Description
Web Server Certificate	<p>To display or delete Certificate which is used when IP phone is connected from any incoming HTTPs request.</p> <p>Note: The default certificate could not be deleted.</p>
Web Server Certificate Upload	<p>Upload certificate file which will be used as server certificate.</p>

Trusted Certificate	To display or delete Certificates which is used when IP phone is connecting to any HTTPs server.
Trusted Certificate Upload	<p>Upload certificate files which will be used as trusted certificate.</p> <ul style="list-style-type: none"> Only Accept trusted Certificates: If this option is enabled, only trusted certificates will be accepted.

5.8.3 Security->Firewall

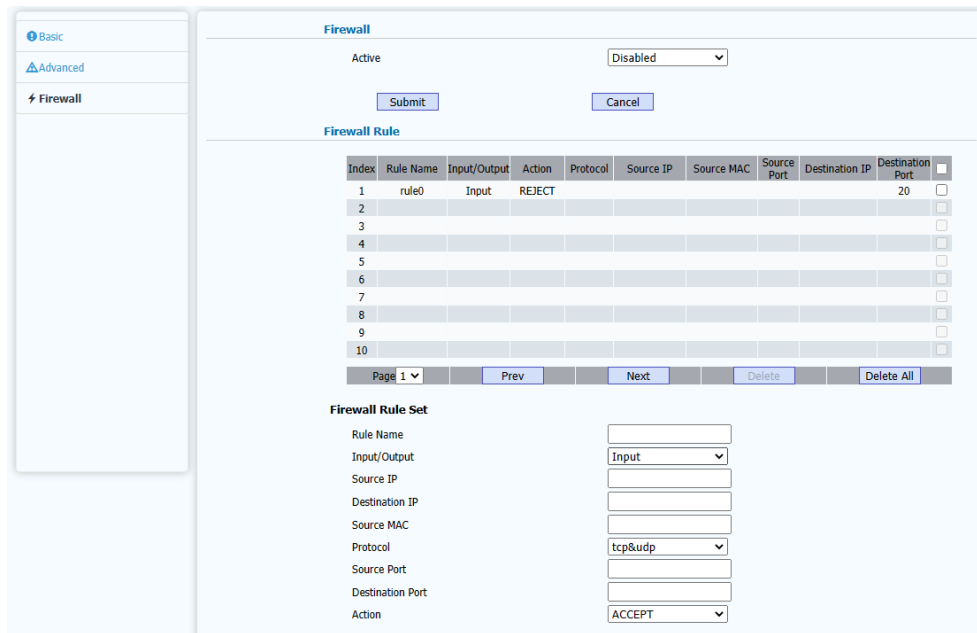

Sections	Description
Firewall	Active: Enable or disable firewall.
Firewall Rule	<ul style="list-style-type: none"> Rule Name: Set rule name. Input/Output: Select the direction of the input and output of the network packet. Source IP: Set source IP. Destination IP: Set the destination IP. Source MAC: Set network source MAC. Protocol: Select the transmission protocol of the network packet. Source Port: Set the network source port. Destination Port: Set the network destination port. Action: To accept or reject network packets to pass.

6 Troubleshooting

Issue 1: The LCD does not light up

- Check the AC power adapter. Make sure it is the one provided in your package.
- Check the power outlet. Make sure that the power that outlet you are plugging your device into is working. Try to plug a different device into the socket to make sure it has power.

Issue 2: No tone heard from the handset

- Check the connection cord between the handset and the phone. Make sure it is connected properly.

Issue 3: Cannot access the web system

- Check the connection between the PC port of the device and the network port of the computer. Make sure it is fine.
- Check whether the IP address of the device is correct.
- If it is LAN, please make sure there is no IP address conflict with other devices on the network.

Issue 4: Cannot call out

- Please see the network connection status of device, if it is exception, and then check the connection of network.
- If the network connection is normal, please check whether the device has registered successfully.
- If the network connection and the registered are both normal, please confirm whether the dial rule is correct, or please communicate with the service operator.

7 Appendix

7.1 Abbreviations

Abbreviation	Explanation
ACD	Automatic Call Distribution
BLF	Busy Lamp Field
CID	Caller Identity
DND	Do NOT Disturb
DTMF	Dual Tone Multi Frequency
DNS	Domain Name System
DHCP	Dynamic Host Configuration Protocol
NAT	Network Address Translation
LDAP	Lightweight Directory Access Protocol
LLDP	Link Layer Discovery Protocol
SNMP	Simple Network Management Protocol
TR069	Technical Report - 069
NMS	Network management system
PNP	Plug-and-Play
PPPoE	point-to-point protocol over Ethernet
NTP	Network Time Protocol
RTP	Real Time Protocol
SIP	Session Initiation Protocol
TCP	Transmission Control Protocol
UDP	User Datagram Protocol
802.1X	IEEE 802.1X
VPN	Virtual Private Network
WLAN	Wireless Local Area Network

7.2 Time Zones

Time Zone	Time Zone Name
-11	Samoa
-10	United States-Hawaii-Aleutian
-10	United States-Alaska-Aleutian
-9	United States-Alaska Time
-8	Canada (Vancouver, Whitehorse)
-8	Mexico (Tijuana, Mexicali)
-8	United States-Pacific Time
-7	Canada (Edmonton, Calgary)
-7	Mexico (Mazatlan, Chihuahua)
-7	United States-Mountain Time
-7	United States-MST no DST
-6	Canada-Manitoba (Winnipeg)
-6	Chile (Easter Islands)
-6	Mexico (Mexico City, Acapulco)
-6	United States-Central Time
-5	Bahamas (Nassau)
-5	Canada (Montreal, Ottawa, Quebec)
-5	Cuba (Havana)
-5	United States-Eastern Time
-4:30	Venezuela (Caracas)
-4	Canada (Halifax, Saint John)
-4	Chile (Santiago)
-4	Paraguay (Asuncion)
-4	United Kingdom-Bermuda (Bermuda)
-4	United Kingdom (Falkland Islands)
-4	Trinidad & Tobago
-4	Curaçao
-3:30	Canada-New Jersey (St. John's Island)

Time Zone	Time Zone Name
-3	Denmark-Greenland (Nuuk)
-3	Argentina (Buenos Aires)
-3	Brazil (no DST)
-3	Brazil (DST)
-2	Brazil (no DST)
-1	Portugal (Azores)
0	GMT
0	Greenland
0	Denmark - Faroe Islands (Torshavn)
0	Ireland (Dublin)0 Portugal (Lisboa, Porto, Funchal)
0	Spain-Canary Islands (Las Palmas)
0	United Kingdom (London)
0	Morocco
+1	Poland (Warsaw)
+1	Albania (Tirane)
+1	Austria (Vienna)
+1	Belgium (Brussels)
+1	Caicos
+1	Chatham
+1	Croatia (Zagreb)
+1	Czech Republic (Prague)
+1	Denmark (Copenhagen)
+1	France (Paris)
+1	Germany (Berlin)
+1	Hungary (Budapest)
+1	Italy (Rome)
+1	Luxembourg (Luxembourg)
+1	Makedonia (Skopje)
+1	Netherlands (Amsterdam)
+1	Namibia (Windhoek)

Time Zone	Time Zone Name
+2	Estonia (Tallinn)
+2	Finland (Helsinki)
+2	Gaza Strip (Gaza)
+2	Greece (Athens)
+2	Israel (Tel Aviv)
+2	Jordan (Amman)
+2	Latvia (Riga)
+2	Lebanon (Beirut)
+2	Moldova (Kishinev)
+2	Russia (Kaliningrad)
+2	Romania (Bucharest)
+2	Syria (Damascus)
+2	Turkey (Ankara)
+2	Ukraine (Kyiv, Odessa)
+3	East Africa Time
+3	Iraq (Baghdad)
+3	Russia (Moscow)
+3	30 Iran (Teheran)
+4	Armenia (Yerevan)
+4	Azerbaijan (Baku)
+4	Georgia (Tbilisi)
+4	Kazakstan (Aqtau)
+4	Russia (Samara)
+5	Kazakstan (Aqtobe)
+5	Kyrgyzstan (Bishkek)
+5	Pakistan (Islamabad)
+5	Russia (Chelyabinsk)
+5	Russia (Yekaterinburg)
+5:30	India (Calcutta)
+6	Kazakstan (Astana, Almaty)

Time Zone	Time Zone Name
+6	Russia (Novosibirsk, Omsk)
+7	Russia (Krasnoyarsk)
+7	Thailand (Bangkok)
+8	China (Beijing)
+8	Singapore (Singapore)
+8	Australia (Perth)
+9	Korea (Seoul)
+9	Japan (Tokyo)
+9:30	Australia (Adelaide)
+9:30	Australia (Darwin)
+10	Australia (Sydney, Melbourne, Canberra)
+10	Australia (Brisbane)
+10	Australia (Hobart)
+10	Russia (Vladivostok)
+10:30	Australia (Lord Howe Islands)
+11	New Caledonia (Noumea)
+12	New Zealand (Wellington, Auckland)
+12:45	New Zealand (Chatham Islands)
+13	Tonga (Nukualofa)
-7	United States-Mountain Time