



MTG5000-64E1 Trunk Gateway User Manual V1.2



Shenzhen Dinstar Co., Ltd.

Address: Floor 18, Building 7A, Vanke Cloud City Phase 1, Xingke 1st Street, Xili Sub-district,
Nanshan District, Shenzhen.

Postal Code: 518052

Telephone: +86 755 61919966

Fax: +86 755 2645 6659

Email: sales@dinstar.com

Website: www.dinstar.com

Welcome

Thanks for choosing **MTG5000-64E1 Trunk Gateway**! We hope you will make optimum use of this flexible, rich-feature trunk gateway. Please read this document carefully before install the gateway.

About this manual

This manual provides information about the introduction of the gateway and about how to install, configure or use the gateway.

This manual is written with reference to the default configurations of the MTG5000-64E1 Trunk Gateway.

Intended audience

This manual is aimed primarily at network and system engineers who will install, configure, and maintain the gateway.

System engineers are persons who customize the configurations to meet the requirements of users. Parts of this document are aimed at users who use the gateway.

Revision Records

Document Name	MTG5000-64E1 Trunk Gateway User Manual v1.2
Document version	V1.2
Software version	03.06.10.30 p50
Revised by	Ellie Zhang
Date	04/05/2023
Descriptions	(1) Update the configuration of default password

Contents

WELCOME.....	1
ABOUT THIS MANUAL.....	1
INTENDED AUDIENCE	1
REVISION RECORDS	1
1 PRODUCT DESCRIPTION	1
1.1 OVERVIEW	1
1.2 APPLICATION SCENARIO	1
1.3 PRODUCT APPEARANCE	1
1.3.1 Description of Ports and Indicators	2
1.4 FUNCTIONS AND FEATURES.....	3
2 QUICK INSTALLATION	6
2.1 PREPARATIONS BEFORE INSTALLATION.....	6
2.1.1 Attentions for Installation.....	6
2.1.2 Preparations about Installation Site	6
2.1.3 Installation Tools.....	7
2.2 INSTALLATION OF MTG5000-64E1	7
2.2.1 Put MTG5000-64E1 into Shelf	7
2.2.2 Connect Grounding wire to MTG5000-64E1.....	7
2.2.3 Connect MTG5000-64E1 to Ethernet	7
2.2.4 Connect MTG5000-64E1 to PSTN	8
2.3 CABLING OF E1/T1 PORT	9
2.3.1 How to make RJ-48 joint for E1/T1 Cable.....	9
3 BASIC OPERATION.....	10
3.1 CONFIGURATION OF IP ADDRESS	10
3.2 LOCAL MAINTENANCE	10
3.2.1 Example: Log in MTG5000-64E1 via Console Port.....	11
3.3 QUERY IP	12
4 CONFIGURATIONS ON WEB INTERFACE.....	14
4.1 HOW TO LOG IN WEB INTERFACE.....	14
4.1.1 Network Connection	14
4.1.2 Preparations for Login.....	14
4.1.3 Log in Web Interface.....	14
4.2 INTRODUCTION TO WEB INTERFACE	15
4.3 CONFIGURATION FLOWS	16
4.4 STATUS & STATISTICS.....	17
4.4.1 System Information.....	17
4.4.2 DTU Status.....	19
4.4.3 E1/T1 Status	20

4.4.4 PSTN Trunk Status.....	22
4.4.5 IP Trunk Status.....	22
4.4.6 SIP Registration Status.....	23
4.4.7 Call Info Status.....	23
4.4.8 PRI Call Statistics	24
4.4.9 SS7 Call Statistics	25
4.4.10 R2 Call Statistics	26
4.4.11 SIP Call Statistics	26
4.4.12 Radius Statistics	27
4.4.13 Record Statistics.....	27
4.4.14 Monitoring Information.....	27
4.5 NETWORK PARAMETER CONFIG.....	28
4.5.1 Network Config.....	28
4.5.2 Static IP Routing Table	29
4.5.3 ACL White List.....	30
4.5.4 ACL Control Config.....	30
4.5.5 VLAN Config.....	31
4.6 PRI CONFIG	32
4.6.1 PRI Parameter	32
4.6.2 PRI Trunk.....	34
4.7 SS7 CONFIG	35
4.7.1 SS7 Parameter	35
4.7.2 SS7 Trunk.....	36
4.7.3 SS7 MTP Link.....	37
4.7.4 SS7 CIC.....	39
4.7.5 SS7 Link Set.....	41
4.7.6 SS7 CIC Maintain	41
4.8 R2 CONFIG	44
4.8.1 R2 Param.....	44
4.8.2 R2 Trunk	48
4.8.3 R2 Setting.....	49
4.9 PSTN GROUP CONFIG.....	49
4.9.1 Clock Source	49
4.9.2 E1/T1 Parameter.....	51
4.9.3 Port Number	52
4.9.4 Codec Group	52
4.9.5 Dial Plan.....	55
4.9.6 Dial Timeout	56
4.9.7 Srtp Param.....	57
4.9.8 PSTN Cause Mapping.....	57
4.9.9 PSTN Profile	58
4.9.10 PSTN Group.....	60
4.9.11 PSTN Group Management	60
4.10 SIP CONFIG.....	62

4.10.1 SIP Parameter	62
4.10.2 SIP Trunk	65
4.10.3 SIP Account	72
4.10.4 SIP DNS	74
4.10.5 SIP RED Group	74
4.11 IP GROUP CONFIG	75
4.11.1 IP Profile	75
4.11.2 IP Group	77
4.11.3 IP Group Management	78
4.12 NUMBER FILTER	78
4.12.1 Procedures to add a number on the Caller White List	79
4.12.2 Caller Pool	80
4.12.3 Number Bound TsNo	80
4.12.4 Filter Profile	81
4.13 CALL ROUTING	82
4.13.1 Routing Parameter	82
4.13.2 PSTN -> IP Routing	82
4.13.3 PSTN -> PSTN Routing	84
4.13.4 IP -> PSTN Routing	85
4.14 NUMBER MANIPULATION	86
4.14.1 PSTN -> IP Callee	86
4.14.2 PSTN -> IP Caller	88
4.14.3 PSTN -> PSTN Callee	90
4.14.4 PSTN -> PSTN Caller	91
4.14.5 IP -> PSTN Callee	93
4.14.6 IP -> PSTN Caller	95
4.15 VOICE & FAX	96
4.16 MAINTENANCE	100
4.16.1 Ping Test	100
4.16.2 Tracert Test	100
4.16.3 Signaling Call Test	101
4.16.4 Network Capture	102
4.16.5 Debug Command	103
4.17 MANAGEMENT	103
4.17.1 Management Parameter	104
4.17.2 Dual MCU Card Parameter	107
4.17.3 Server Parameter	108
4.17.4 Cloud Server	110
4.17.5 NMS Server	110
4.17.6 Mail Server	111
4.17.7 SNMP Parameter	112
4.17.8 Radius Parameter	114
4.17.9 Remote Server	116
4.17.10 Data Download	116

4.17.11 Data Restore	117
4.17.12 License Management.....	118
4.17.13 Version Information	118
4.17.14 Firmware Upload.....	119
4.17.15 User Account Management	122
4.17.16 User Group Management	122
4.17.17 Password Modification.....	124
4.17.18 Auto Reset.....	124
4.17.19 Device Restart	124
5 ABBREVIATION.....	126
6 COMMANDS	127
6.1 COMMANDS UNDER EN MODE.....	127
6.1.1 Login Command.....	127
6.1.2 Query IP Address	127
6.1.3 Query Statistics about DTU	127
6.1.4 Query DSP Information	128
6.1.5 Query CPU Performance.....	128
6.1.6 Query SS7 Trunk Status	128
6.1.7 Query SS7 Link Statistics	129
6.1.8 Query SS7 Call Statistics	129
6.1.9 Query SS7 Errors	129
6.1.10 Query PRI Trunk Status	129
6.1.11 Query PRI Link Statistics.....	130
6.1.12 Query PRI Call Statistics.....	130
6.1.13 Query Packet Statistics of HDLC Channel and Related Error Codes	130
6.1.14 Query Status of E1 Port.....	131
6.1.15 Query Statistics of All Call	131
6.2 COMMANDS UNDER CONFIG MODE	131
6.2.1 Login Commands	131
6.2.2 Other Commands	132
6.3 COMMANDS UNDER ADA MODE	132
6.3.1 Login Commands	132

1 Product Description

1.1 Overview

MTG5000-64E1 is a new-generation of intelligent trunk gateway designed by Dinstar to meet the business needs of call centers or large enterprises. Based on a maintainable, manageable, and operational design concept, MTG5000-64E1 can achieve translation between traditional signaling SS7, PRI, R2 and SIP protocols, and provide signaling encryption and voice recognition technology, which not only ensures the voice quality but also improves the efficiency of resource usage. In addition, it integrates enhanced functions such as IP voice, IP fax, and Modem to provide users with a flexible, efficient, and future-oriented communication network.

1.2 Application Scenario

The application scenario of MTG5000-64E1 is shown as follow:

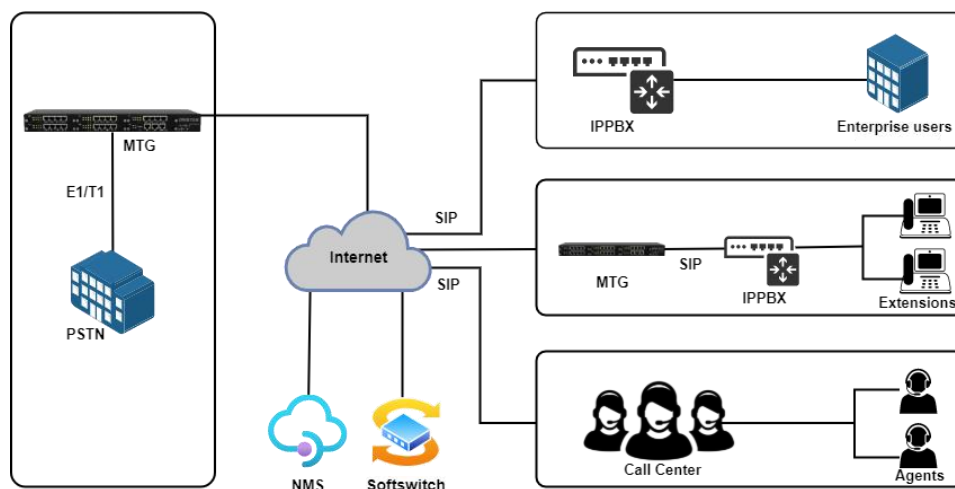

1.3 Product Appearance



Front View



Power Jack 1

Power Jack 2

Back View

1.3.1 Description of Ports and Indicators

Table 1-3-1 Description of Ports

Port	Description
PWR	Power jack: 100~240VAC, 50~60HZ
Port0-Port63	E1/T1 ports; support 4~64 E1 ports
CONSOLE	The console port used to carry out maintenance-related configurations, with a baud rate of 115200bps.
GE1	The gigabit Ethernet port for services, which is used to transfer the data transmission of signal or voice. Its default IP address is 192.168.1.111, and default netmask is 255.255.255.0.
GE0	The gigabit Ethernet port for network management; its default IP address is 192.168.11.1, and default netmask is 255.255.255.0.
RST	The button is used to restart MTG5000-64E1.

Table 1-3-2 Description of Indicator

Indicator	Definition	Status	Description
PWR	Power Indicator	On	Power supply is working as normal.
		Off	There is no power supply or power supply is down.
RUN	Running Indicator	Slow Flashing	The device is initialized successfully and running normally.
		On	The system is initializing.
		Off	The device is not running successfully.
E1/T1	E1/T1 Indicator	On	The E1/T1 port is connected successfully, and can be used to receive or send data.
		Off	E1 line E1 is disconnected.
		Flash	The E1/T1 port is connected falsely and there are bit errors.
GE0/GE1	LINK Indicator	Fast Flashing	The network connection is normal.
		Off	The network is disconnected or the network connection is wrong.
	SPEED Indicator	On	The network speed is 1000Mbps
		Off	The network speed is lower than 1000Mbps

1.4 Functions and Features

➤ Key Features

- Carrier grade hardware design, 1+1 power supply and MCU, hot plug
- High-integrated structure, STM-1 155M (64*E1) in U3.5 size
- Provide various services such as VoIP, IP fax, Modem and POS;
- Support flexible dialing rules and operations, allowing users to customize dialing rules according to different working environments;
- Support multiple coding standards: G.711A/U, G.723.1, G.729A/B and iLBC, AMR;
- Support PRI/SS7/R2, SIP/IMS
- ISDN PRI 30B+D(E1), NT or TE can be configured ITU-T Q.921, ITU-T Q.931, Q.Sig
- SS7 ITU-T, ANSI, ITU-CHINA MTP1/MTP2/MTP3, TUP/ISUP
- E1 frame format type: DF, MF-CRC, MF
- T1 frame format type: F12/SF (R2 does not support), F24/ESF

➤ **Protocols Supported**

- Standard SIP/ SIP-T /PRI/SS7/R2 protocol
- UDP/TCP/TLS
- Dynamic NAT
- Hypertext Transfer Protocol (HTTP) and Hypertext Transfer Security Protocol (HTTPS)
- ITU-T G.711A-Law/U-Law, G.723.1, G.729A/B, iLBC13k/15k, AMR
- Domain Name System (DNS)
- SIP, RFC3261, RFC3262
- SDP/SRTP, RFC4566, RFC3711
- RTP/RTCP, RFC3550, RFC3605, RFC1889
- SIP-T, RFC3372, RFC3204, RFC3398
- RFC3263, RFC3264, RFC3265, RFC3515, RFC2976, RFC3311

➤ **System Functions**

- Packet Loss Concealment (PLC)
- Voice Activity Detection (VAD)
- Comfort Noise Generation (CNG)
- Echo Cancellation
- Packet Loss Compensation
- Adaptive Jitter Buffer
- DTMF Modes: RFC2833, SIP INFO and INBAND
- T38/Pass-Through Fax over IP
- Configurations via HTTPS/SSH
- Upgrade Firmware via TFTP/Web

➤ **Software Features**

- Local/Transparent Ring Back Tone
- Overlapping Dialing
- Dialing Rules, with up to 2000
- PSTN Group Based on E1 Port or E1 Timeslot
- Configuration of IP Trunk Group

- Voice Codec Group
 - Caller/Called Number White List
 - Caller/Called Number Black List
 - Access Rule List
 - IP Trunk Priority
 - RTP and Signaling Encryption (VOS RC4)
 - Voice Recording
 - Radius
 - SNMP v1/v2/v3
 - NMS
- **Hardware Specifications & Environment**
- Power Supply: 100 ~ 240V AC, 50 ~60Hz
 - Power Consumption: 125W
 - Operating Temperature: 0 °C ~ 45 °C
 - Storage Temperature: -20 °C ~80 °C
 - Humidity: 10%-90%, Non-Condensing
 - Dimensions (W/D/H): 437×345×154mm (3.5U)
 - Unit Weight: 12.8kg
 - Compliance: CE and FCC

2 Quick Installation

2.1 Preparations before Installation

2.1.1 Attentions for Installation

The attentions for installing MTG5000-64E1 include:

- To guarantee MTG5000-64E1 works normally and to lengthen the service life of the device, the humidity of the equipment room where MTG5000-64E1 is installed should be maintained at 10%-90% (non-condensing), and temperature should be 0 °C ~ 45 °C;
- Ensure the equipment room is well-ventilated and clean;
- Power supply of MTG5000-64E1 should be 100 ~ 240V AC, and its socket is a three-pin socket which should be grounded well;
- It's suggested that personnel who has experience or who has received related training be responsible for installing and maintaining MTG5000-64E1;
- Please wear anti-static wrist strap when installing MTG5000-64E1;
- It's advised to adopt uninterruptible power supply.

2.1.2 Preparations about Installation Site

- **Equipment Cabinet**

Ensure the cabinet is well-ventilated and strong enough to bear the weight of MTG5000-64E1. It's required that the width of the shelf should be 19 inches.

- **Trunk**

Ensure telecom operator has approved to open a trunk.

- **IP Network**

Ensure Ethernet PBX or router under IP network has been prepared, since MTG5000-64E1 is connected to the IP network through the standard 10/100/1000M Ethernet port.

- **Socket**

Ensure the socket of MTG5000-64E1 is a three-pin socket, and power supply is grounded well.

2.1.3 Installation Tools

- Screwdriver
- Anti-static wrist strap
- Ethernet cables, power wires, telephone wires
- Hub, telephone set, fax, and PBX
- Terminal (can be a PC which is equipped with hyper terminal simulation software)

2.2 Installation of MTG5000-64E1

2.2.1 Put MTG5000-64E1 into Shelf

1. Use screws to fix a flank on the left and the right of MTG5000-64E1 respectively;
2. Put the MTG5000-64E1 device into the shelf horizontally;
3. Fix the flanks of MTG5000-64E1 on the cabinet by using screws.

2.2.2 Connect Grounding wire to MTG5000-64E1

Connect one end of the Grounding wire to the grounding lug on the back of MTG5000-64E1 and then connect the other end to the grounding bar of the shelf.

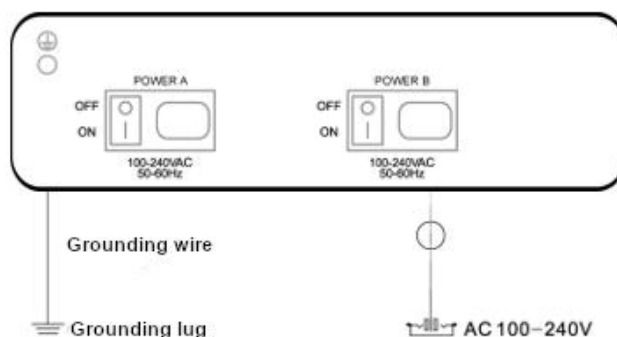

2.2.3 Connect MTG5000-64E1 to Ethernet

MTG5000-64E1 has two network ports, namely the gigabit Ethernet port for services (GE1) and the gigabit Ethernet port for network management (GE0). It is advised to connect GE1 to the IP network.

Both GE1 and GE0 can be used to carry out management on MTG5000-64E1, but only GE1 is put in use generally. GE0 is used when there is a need to separate the management on MTG5000-64E1 from the service processing of the MTG5000-64E1. As shown below:

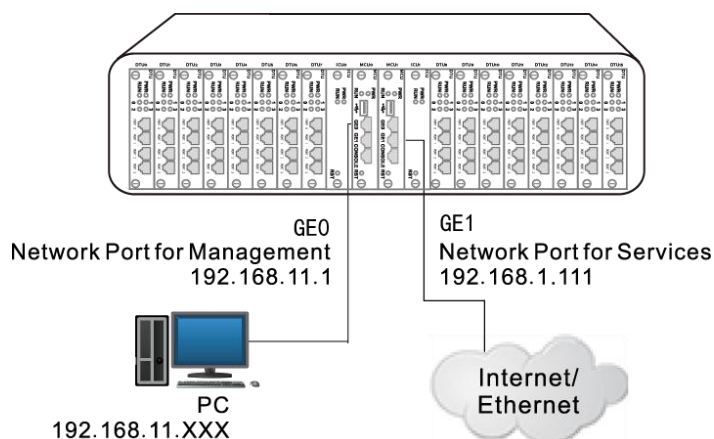

2.2.4 Connect MTG5000-64E1 to PSTN

Generally, a distribution frame needs to be used for the connection between MTG5000-64E1 and PSTN. Firstly, connect one end of E1/T1 cable to one of the E1/T1 ports of MTG5000-64E1, and then connect other end to the E1 port of the distribution frame. Second, connect one end of the cable to the distribution frame, and then connect the other end to the exchanger or PBX under the PSTN.

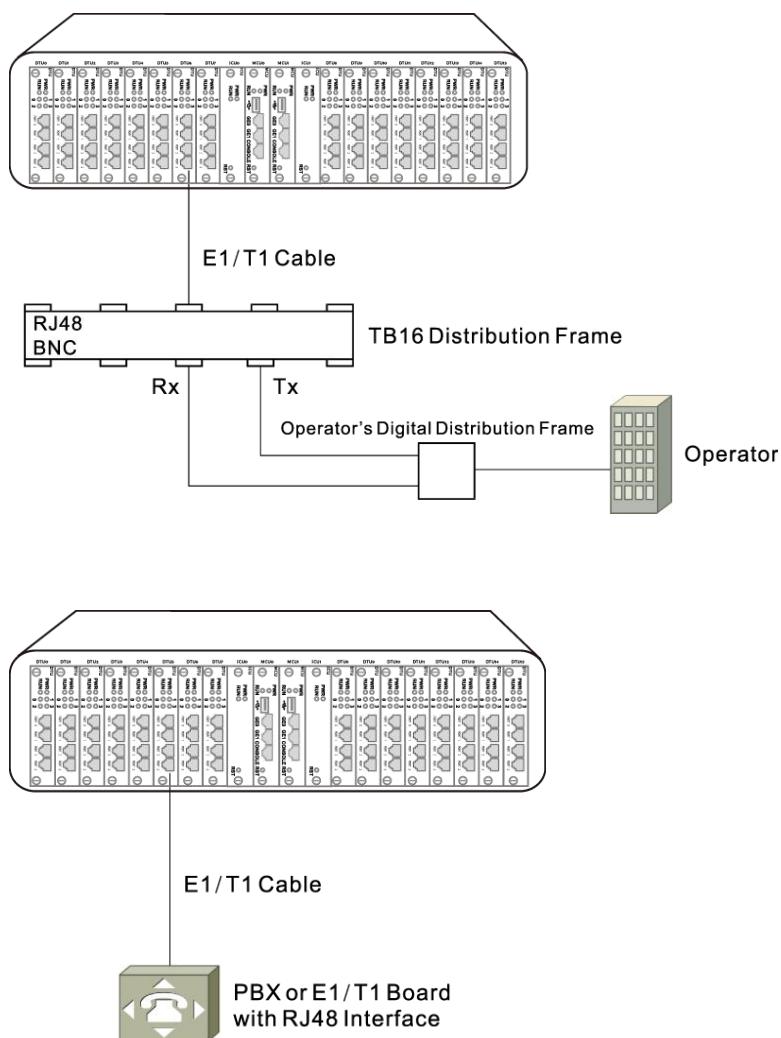

2.3 Cabling of E1/T1 Port

If there is a need to deploy multiple cables, it had better to make a mark on each cable and write down IP address and destination port in order to simplify the follow-up connection, debugging and maintenance.

2.3.1 How to make RJ-48 joint for E1/T1 Cable

1. Prepare a twisted-pair cable with a length of at least 0.6 meters, and then remove the shuck of the cable as follows:
2. Sequence the lines of the cable according to the following figure.

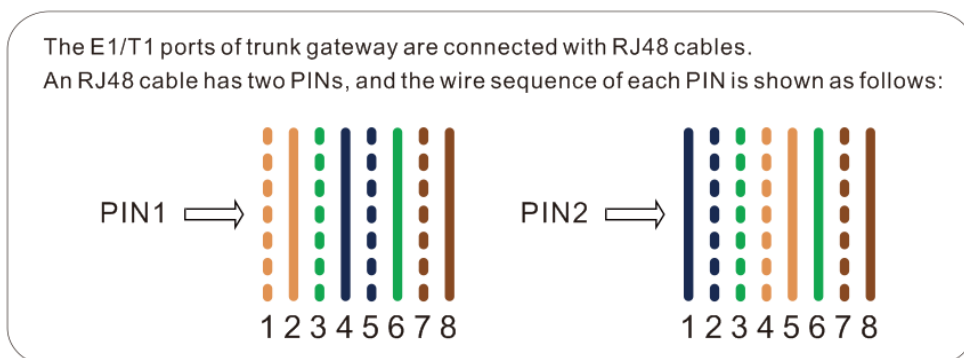

PIN1: orange & white, orange, green & white, blue, blue & white, green, brown & white, brown.

PIN2: blue, blue & white, green & white, orange & white, orange, green, brown & white, brown.

3. Put the lines into two pins of RJ-48 joint according to the above mentioned sequence of the lines.
4. Use a RJ-48 wire crimper to crimp the RJ-48 joint.



Note:

Generally, a RJ-48 cable will be provided together with the MTG5000-64E1 device, and users have no need to make RJ-48 joints by themselves.

3 Basic Operation

3.1 Configuration of IP Address

The default IP address of GE1 is 192.168.1.111, while that of GE0 is 192.168.11.1. When GE1 is in use, it's required that the IP address of GE1 and the IP address of PC are at the same network segment.

1. Connect the GE1 port of MTG5000-64E1 to a PC by using a network cable.
2. Open the TCP/IP Settings interface, click **Advanced**, and then click **Add** to add an IP whose format is 192.168.1.XXX. Or you can open the Internet Protocol (TCP/IP) interface to modify an existing IP into 192.168.1.XXX.

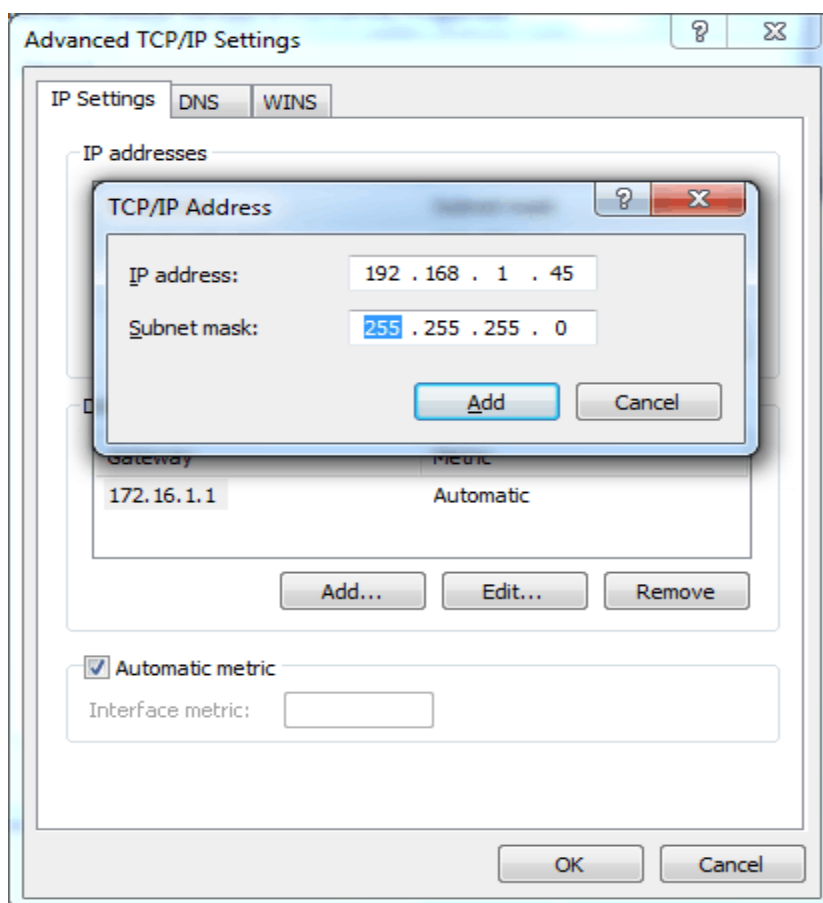

3.2 Local Maintenance

To ensure easy maintenance, the MTG5000-64E1 trunk gateway provides a standard RJ45 console port, which has a Baud rate of 115200bps. Users can log in the MTG5000-64E1 to carry out maintenance-related configurations through the console port.

3.2.1 Example: Log in MTG5000-64E1 via Console Port

Step 1: Prepare a serial cable.



Step 2: Connect the F port of the serial cable to the COM port of PC.

If the PC does not have a COM port, please use a USB-to-COM converting line to connect the serial cable to the PC.

Step 3: Connect the M port of the serial cable to the console port of MTG5000-64E1

Step 4: Conduct configurations on login software.

Herein we take the PuTTY as an example. Detailed configurations are as follows (COM1 is an example. Please enter correct serial line according to actual conditions.)

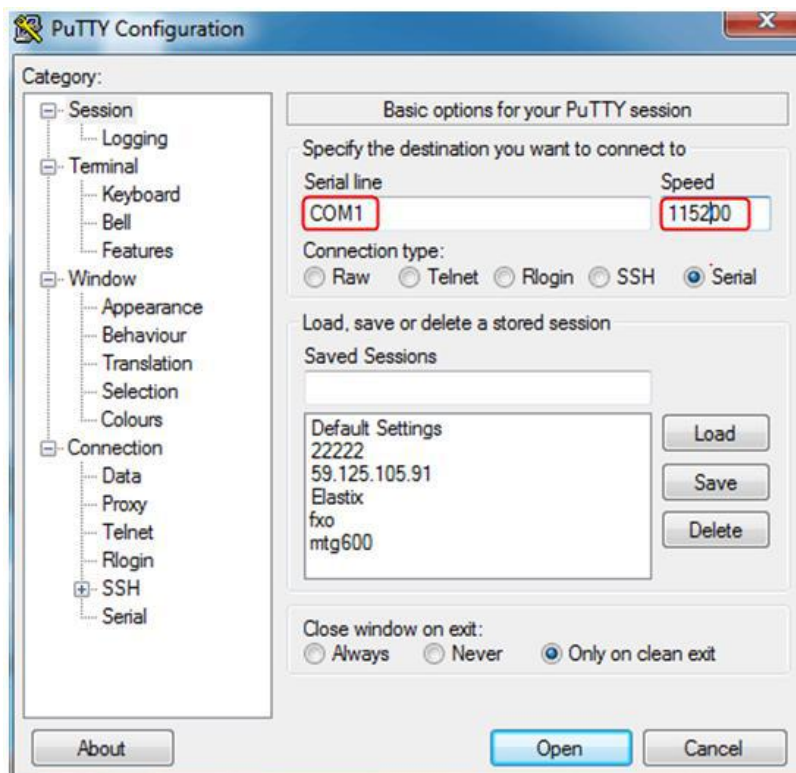

After finishing the above configuration, click the Open button to enter the following interface.

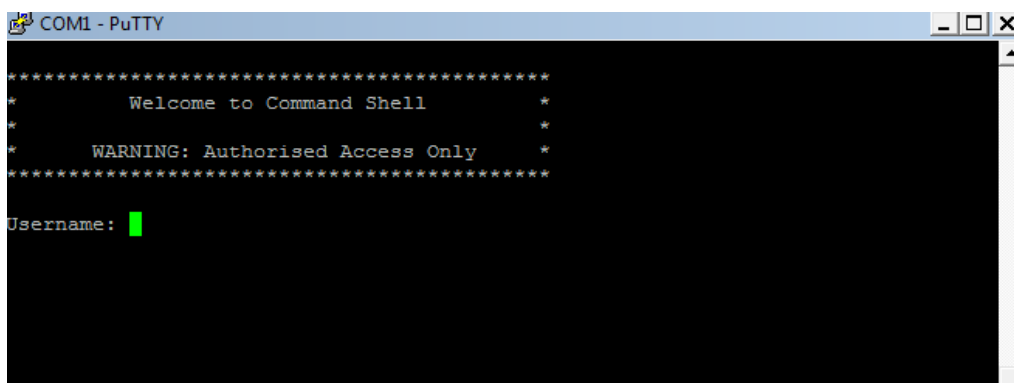

Enter username and password, which are the same with the username and password of the Web of MTG5000-64E1. And then you will see a Linux platform where you can carry out maintenance-related configurations.

Note:

For commands to query MTG5000-64E1 information, make reference to Chapter 6.

3.3 Query IP

If you have changed the default IP address of GE1 or GE0 to a new IP address but forget it, you can carry out the following procedures to query the IP address.

1. Use a serial line to connect the console port of MTG5000-64E1 with a PC;
2. Modify the baud rate to 115200;

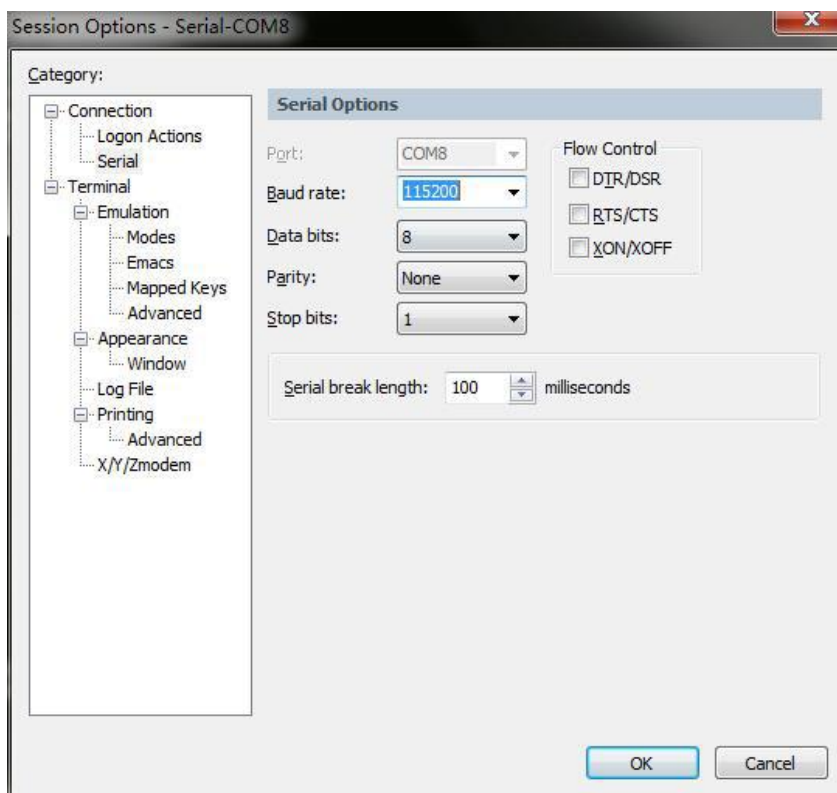

3. Click OK, and then enter 'ifconfig', and the IP address of GE1 or GE0 of MTG5000-64E1 will be displayed.

```
/#  
/# ifconfig  
eth0 Link encap:Ethernet Hwaddr 00:5A:E4:56:38:04  
inet addr:172.16.222.2 Bcast:172.16.255.255 Mask:255.255.0.0  
UP BROADCAST RUNNING MULTICAST MTU:1400 Metric:1  
RX packets:504166 errors:0 dropped:0 overruns:0 frame:0  
TX packets:484002 errors:0 dropped:0 overruns:0 carrier:0  
collisions:0 txqueuelen:532  
RX bytes:37862449 (36.1 MiB) TX bytes:50977065 (48.6 MiB)  
Interrupt:11  
  
eth1 Link encap:Ethernet Hwaddr 00:12:34:56:78:01  
inet addr:192.168.11.1 Bcast:192.168.11.255 Mask:255.255.255.0  
UP BROADCAST RUNNING MULTICAST MTU:1500 Metric:1  
RX packets:0 errors:0 dropped:0 overruns:0 frame:0  
TX packets:0 errors:0 dropped:0 overruns:0 carrier:0  
collisions:0 txqueuelen:532  
RX bytes:0 (0.0 B) TX bytes:0 (0.0 B)  
Interrupt:15  
  
/#  
/#
```

4 Configurations on Web Interface

4.1 How to Log in Web Interface

4.1.1 Network Connection

Connect MTG5000-64E1 to the network according to the following network topology:

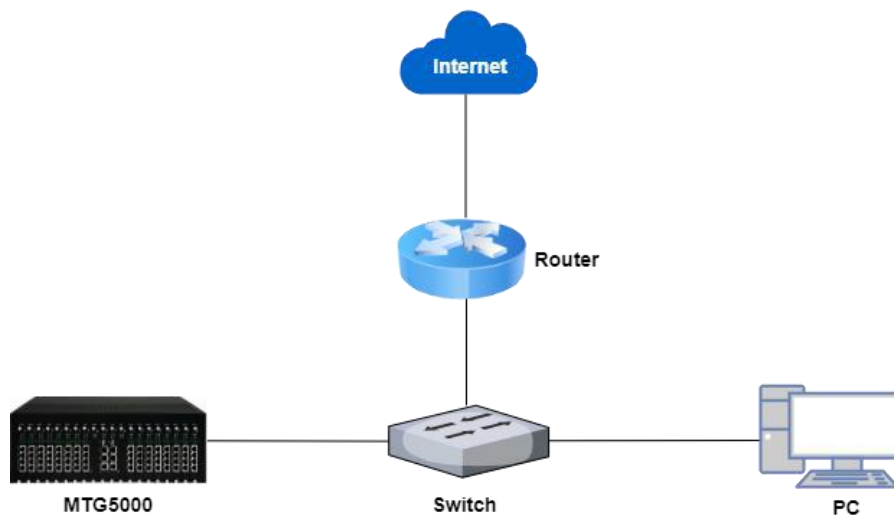

4.1.2 Preparations for Login

Modify the IP address of the PC to make it at the same network segment with the IP address of GE1 port of MTG5000-64E1. The format of PC IP is 192.168.1.XXX, since the default IP of GE1 port is 192.168.1.111.

Check the connectivity between the PC and the MTG5000-64E1. Click **Start**-> **Run** of PC and enter cmd to execute 'ping 192.168.1.111' to check whether the IP address of the MTG5000-64E1 runs normally.

4.1.3 Log in Web Interface

Open a web browser and enter the IP address of GE0 of MTG5000-64E1 (the default IP is 192.168.11.1). Then the login GUI will be displayed. Enter the correct username and password. By default, username and password are as below:

User Name: **admin**

Password: **admin@123#**

It is suggested that you should modify the username and password for security consideration on the **Maintenance** -> **Password Modification** interface.

Login GUI:

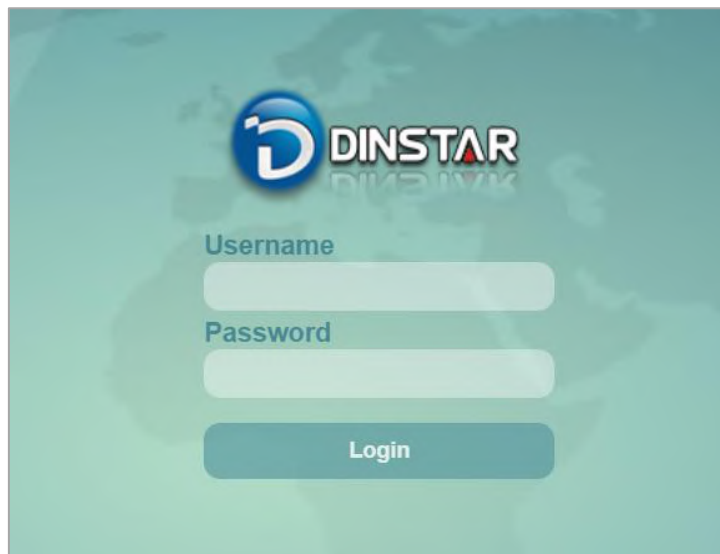

Password Modification Interface:

Password Modification

Old Password

New Password
6~32 characters and is case sensitive

Confirm Password
Please fill in the password again

4.2 Introduction to Web Interface

The Web Interface of the MTG5000-64E1 consists of the navigation tree and detailed configuration interfaces.

Click a node of the navigation tree, and you will see a detailed display interface or configuration interface:

The screenshot shows the 'Web Management System' interface. On the left is a 'Navigation Tree' with a red box around it, containing a list of menu items such as 'Status & Statistics', 'System Information', 'E1/T1 Status', 'PSTN Trunk Status', 'IP Trunk Status', 'SIP Registration Status', 'Call Info Status', 'PRI Call Statistics', 'SS7 Call Statistics', 'SIP Call Statistics', 'Radius Statistics', 'Record Statistics', 'Network Param Config', 'PRI Config', 'SS7 Config', 'PSTN Group Config', 'SIP Config', 'IP Group Config', 'Number Filter', 'Call Routing', 'Number Manipulation', 'Voice & Fax', 'Maintenance', and 'Management'. A red arrow points from the 'Navigation Tree' label to this list. On the right is a 'Configuration Interface or Display Interface' (also labeled with a red arrow) showing 'System Information'. This interface is divided into 'General' and 'Version' sections.

General			
CPU ID	E4-69-7C-D7-53-47-26-2B		
CPU Temperature	56°C	Usage(60s)	9%
GE1 MAC-Work Mode	F8-AD-3D-40-26-50	1000M/Full-duplex	
GE0 MAC-Work Mode	F8-AD-3D-40-26-51	down	
Service Ethernet Interface(GE1)	172.28.26.50	255.255.0.0	172.28.1.1
Management Ethernet Interface(GE0)	192.168.11.1	255.255.255.0	0.0.0.0
DNS Server	8.8.8.8	0.0.0.0	0.0.0.0
Device ID	3030-69d0-3d40-2650		
Cloud Server Register Status	Not Registered		
System Time	2021-7-16 15:15:30		
System Uptime	8 m 53 s		
GE1 Network Speed(Kbit/s)	Received	23	Sent 30
GE0 Network Speed(Kbit/s)	Received	0	Sent 0
Current Mcu Card	MCU0		
Slave Card Communication	SUCC		
Version			
Device Model	MTG5000-64E1		
Hardware Version	PCB 07.01, BackBoardID 2		
Boot Version	17	Kernel Version	27
Software Version	03.06.10.30 p50	Web Version	03.06.10.30 p50
Time Built	2021-07-01, 11:33:52		

4.3 Configuration Flows

The following is the configuration flows of MTG5000-64E1:

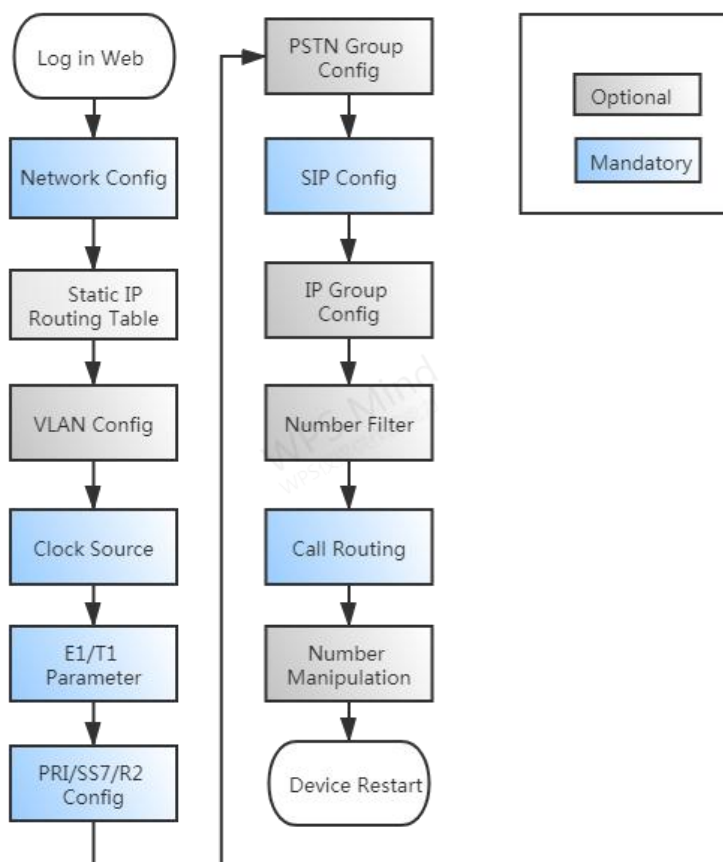

4.4 Status & Statistics

This interface menu displays all the main operating information related to the MTG gateway, including system information, DTU status, physical connection status, PRI/SS7/R2 signaling status, SIP registration status, other call statuses and other call statistics. This menu bar allows users to get most of the operating information of the MTG device. Through this information, users can access relevant statistics and basic MTG operation data.

Note: Depending on the different models, the information displayed in this interface and submenus may be different. If you have any questions, please contact the official technical staff.

4.4.1 System Information

Click **Status & Statistics** -> **System Information** in the navigation tree on the left, and the following interface will be displayed. On the interface, information about the system, such as Mac address, CPU usage, hardware version and software version, are shown.

System Information				
General				
CPU ID	E4-69-7C-D7-53-47-26-2B			
CPU Temperature	56°C	Usage(60s)	9%	
GE1 MAC-Work Mode	F8-A0-3D-40-26-50	1000M/Full-duplex		
GE0 MAC-Work Mode	F8-A0-3D-40-26-51	down		
Service Ethernet Interface(GE1)	172.28.26.50	255.255.0.0	172.28.1.1	
Management Ethernet Interface(GE0)	192.168.11.1	255.255.255.0	0.0.0.0	
DNS Server	8.8.8.8	0.0.0.0		
Device ID	3030-f8a0-3d40-2650			
Cloud Server Register Status	Not Registered			
System Time	2021-7-16 15:15:30			
System Uptime	8 m 53 s			
GE1 Network Speed(Kbit/s)	Received	23	Sent	30
GE0 Network Speed(Kbit/s)	Received	0	Sent	0
Current Mcu Card	MCU0			
Slave Card Communication	SUCC			
Version				
Device Model	MTG5000-64E1			
Hardware Version	PCB 07.01, BackBoardID 2			
Boot Version	17	Kernel Version	27	
Software Version	03.06.10.30 p50	Web Version	03.06.10.30 p50	
Time Built	2021-07-01 , 11:33:52			

Belong to	Parameter	Explanation	
General	CPU ID	CPU ID number of the device	
	CPU Temperature	CPU real-time temperature	
	Usage(60s)	The CPU usage within 60s	
	GE1 MAC-Work Mode	The MAC address of GE1 and the network port work mode between the device and the switch.	
	GE0 MAC-Work Mode	The MAC address of GE0 and the network port work mode between the device and the switch.	
	Service Ethernet Interface (GE1)	IP address, subnet mask, gateway of the Service Ethernet Interface	
	Management Ethernet Interface (GE0)	IP address, subnet mask, gateway of the Management Ethernet Interface	
	DNS Server	IP address of the DNS server	
	Device ID	Device serial number, automatically generated by MAC address	
	Cloud Server Register Status	If the cloud server is configured and registered successfully, it shows registered, otherwise it shows not registered.	
	System Time	Current time (the time will be displayed correctly only after successful synchronization of the NTP clock)	
	System Uptime	Continuous operating time of the equipment since start-up	
	License	Display the type of license, official/trial	
	GE1 Network Speed (Kbit/s)	The current receive/send rate of the network port	
	GE0 Network Speed (kbit's)	The current receive/send rate of the network port	
	Version	Current MCU Card	Display the current main control unit slot
		Slave Card Communication	Display the connection status of the master and slave boards
Device Model		Display the model of the equipment	
Hardware Version		Display the hardware version of the device	
Boot Version		Display the boot version in DMS	
Kernel Version		Display the kernel version in DMS	
Software Version		Display the software version of the running device	
Web Version	Display the version of the device's WEB interface		
Time Built	Display the compilation time of the current software version		

4.4.2 DTU Status

Click **Status & Statistics** -> **DTU Status** in the navigation tree, and the information of DTU card and DTU channel are displayed.

Dtu Card Information									
DTU No.	Link Status	DSP	Status	License	Temperature	DSP	Status	License	Temperature
DTU 0	Active	0	Success	256	28°C	1	Success	256	28°C
DTU 1	Active	2	Success	256	37°C	3	Success	256	35°C
DTU 2	Active	4	Success	256	36°C	5	Success	256	34°C
DTU 3	Active	6	Success	256	35°C	7	Success	256	37°C
DTU 4	Active	8	Success	256	40°C	9	Success	256	39°C
DTU 5	Active	10	Success	256	44°C	11	Success	256	44°C
DTU 6	Active	12	Success	256	34°C	13	Success	256	35°C
DTU 7	Active	14	Success	256	44°C	15	Success	240	43°C
DTU 8	Active	16	Success	256	35°C	17	Success	256	35°C
DTU 9	Active	18	Success	256	36°C	19	Success	256	35°C
DTU 10	Active	20	Success	256	39°C	21	Success	256	39°C
DTU 11	Active	22	Success	256	40°C	23	Success	256	39°C
DTU 12	Active	24	Success	256	38°C	25	Success	256	40°C
DTU 13	Active	26	Success	256	37°C	27	Success	256	38°C
DTU 14	UnConnected	28	Fault	---	---	29	Fault	---	---
DTU 15	UnConnected	30	Fault	---	---	31	Fault	---	---

Parameter	Explanation
DTU No.	The slot number of User board.
Link Status	The link status of DTU and MCU.
DSP	The number of DSP.
Status	The status of DSP.
License	The number of authorized ports for the DSP.
Temperature	The temperature of DTU.

Dtu Channel Information						
DTU No.	Active	Book	Idle	DspCap	Port Range	
DTU 0	4	0	124	5708	6144-6656	
DTU 1	4	0	124	5708	6656-7168	
DTU 2	4	0	124	5708	7168-7680	
DTU 3	4	0	124	5708	7680-8192	
DTU 4	4	0	124	5708	8192-8704	
DTU 5	4	0	124	5708	8704-9216	
DTU 6	4	0	124	5708	9216-9728	
DTU 7	4	0	124	5708	9728-10240	
DTU 8	4	0	124	5708	10240-10752	
DTU 9	4	0	124	5708	10752-11264	
DTU 10	4	0	124	5708	11264-11776	
DTU 11	4	0	124	5708	11776-12288	
DTU 12	4	0	124	5708	12288-12800	
DTU 13	4	0	124	5708	12800-13312	

Parameter	Explanation
DTU No.	The slot number of User board.

Active	The number of transcoding pairs allocated.
Book	The number of pre-allocated transcoding pairs.
Idle	The number of free transcoding pairs.
DspCap	Remaining DSP capability.
Port Range	RTP port range for each user board.

4.4.3 E1/T1 Status

Click **Status & Statistics** -> **E1/T1 Status** in the navigation tree, and the status of each E1/T1 port is displayed.

E1/T1 Port Status

Port No.	0	1	2	3	4	5	6	7	8	9	10	11	12	13	14	15
DTU 0~3																
DTU 4~7																
DTU 8~11																
DTU 12~15																







NOTES: ■ Activated ■ Disable ■ Not Authorized ■ LOS Alarm ■ DTU not Registered
■ RAI Alarm ■ AIS Alarm ■ ISDN/SS7 Signal Alarm ■ Auto Closed

E1/T1 Channel Status

Channel No.	0	1	2	3	4	5	6	7	8	9	10	11	12	13	14	15	16	17	18	19	20	21	22	23	24	25	26	27	28	29	30	31	
Port 0																																	
Port 1																																	
Port 2																																	
Port 3																																	
Port 4																																	
Port 5																																	
Port 6																																	
Port 7																																	
Port 8																																	
Port 9																																	
Port 10																																	
Port 11																																	
Port 12																																	
Port 13																																	
Port 14																																	
Port 15																																	

caller: called:

Status	Frame-S...	Idle	Signal	Progress	Ring	Talk	Release	Fault	Disable	L-block...	R-bloc...	B-bloc...
Color												
Totalize	0	0	0	0	0	0	0	0	512	0	0	0

Belong to	Parameter	Explanation
Status of E1/T1 Port	 Actived	Both physical connection and signal connection of the E1/T1 port are normal, and the port is activated.
	 Disable	The E1/T1 port is not used.
	 LOS Alarm	Alarm for loss of signal. If the LOS alarm is raised, please check physical network connection.
	 RAI Alarm	RAI (Remote Alarm Indication) is an alarm for lost of remote signal. The alarm is sent by the remote device and received by MTG5000-64E1.
	 AIS Alarm	AIS (Alarm Indication Signal) is an alarm raised by MTG5000-64E1, indicating the peer device malfunctions, or signal/physical connections are abnormal.
	 ISDN/SS7 Signal Alarm	This alarm means physical connection is normal while signal connection is abnormal.
E1/T1 Channel Status	Frame-Sync	Frame synchronization
	Idle	The channel is available, and related cables are connected normally.(The channel is used to transmit voice)
	Signal	The channel is used to transmit signal.
	Busy	The E1/T1 channel is being used by voice.
	Fault	The channel is normal while cables are not successfully connected.
	Disable	The E1/T1 trunk is not used.
	L-blocked	The E1/T1 channel is blocked at local end, but not blocked at remote end.
	R-blocked	The E1/T1 channel is blocked at remote end, but not blocked at local end.
	B-block	The E1/T1 is blocked at both local end and remote end.

4.4.4 PSTN Trunk Status

On the **PSTN Trunk Status** interface, the statuses of PRI/SS7 trunks are displayed. The PRI/SS7 trunks under PSTN need to be established at the **PRI Config -> PRI Trunk** interface or the **SS7 Config -> SS7 Trunk** interface first.

PRI Link Status					
PRI Trunk No.	Trunk Name	E1/T1 Port No.	Link Status	Send Frames Num	Recv Frames Num
---	---	---	---	---	---
					Total: 0 ▼

SS7 Link Status					
SS7 Trunk No.	Trunk Name	E1/T1 Port No.	Link Status	Send Frames Num	Recv Frames Num
---	---	---	---	---	---

R2 Link Status					
R2 Trunk No.	Trunk Name	E1/T1 Port No.	Link Status	Send Cas Num	Recv Cas Num
---	---	---	---	---	---

4.4.5 IP Trunk Status

On the **IP Trunk Status** interface, the statuses of SIP trunks are displayed. The SIP trunks need to be established at the **SIP Config -> SIP Trunk** interface first.

SIP Trunk Status					
Trunk No	Trunk Name	Trunk Mode	Protocol Type	Incoming Authentication Type	Link Status
0	5.230	Peer	UDP	IP Address	Established
1	Ag2.150	Peer	UDP	IP Address	Established

Parameter	Explanation
Trunk Name	This trunk name is the name used to register the SIP trunk. If the SIP trunk is not registered, the trunk name is displayed as “---”.
Trunk Mode	There are two trunk modes: peer (peer-to-peer) and access.
Incoming Authentication Type	Incoming calls can be authenticated through password or IP address.
Link Status	There are two link statuses: Established and Fault.

4.4.6 SIP Registration Status

SIP Registration Status Stat		
SIP Account Count	Registered Fail Count	Registered Succ Count
0	0	0

Filter Condition			
Registration Status	All	Filter	Refresh

SIP Account Registration Status						
ID	Account Name	Trunkno	User Name	Max calls	Curr calls	Registration Status
---	---	---	---	---	---	---

Total: 0

Parameter	Explanation
ID	The ID of the SIP account
Account Name	Description of the SIP account, used to identify the account
Trunk No.	The No. of the trunk bound to the SIP account
Username	The username of the SIP account
Max Calls	The maximum number of concurrent calls set for the SIP account
Current Calls	The number of current calls that are using the SIP account
Registration Status	There are three statuses, namely normal, fault and disabled. If the status is normal, it means the current SIP account has been registered successfully.

4.4.7 Call Info Status

Filter Call Informations			
Trunk Number	Call Number	call status	
0		*	Filter clear

Show Call Informationso				
Source Trunk	Destination Trunk	Calling Number	Called Number	Call Status
---	---	---	---	---

Prev Next Page:1/Total Tage:1 (Total Info0)

Notice:Only show 60 informations, when the informations more than 60

Notice:the character * can to match every character(just like Regular Expressions *)

Parameter	Explanation
Source Trunk	The No. of the source SIP/PSTN trunk of the call
Destination Trunk	The No. of the destination SIP/PSTN trunk of the call
Calling Number	The caller number of the call
Called Number	The called number of the call
Call Status	The connection or disconnection status of the call, such as alerting, active and release

4.4.8 PRI Call Statistics

On the **PRI Call Statistics** interface, information about PRI calls and statistics about call release causes are displayed.

ASR (Answer-seizure Ratio): is a call success rate, which reflects the percentage of answered telephone calls with respect to the total call volume. $ASR = \text{answered call} / \text{total attempts of calls}$.

ACD (Average Call Duration): is a measurement in telecommunication, which reflects an average length of telephone calls transmitted on telecommunication networks. $ACD = \text{total call duration} / \text{total connected calls}$.

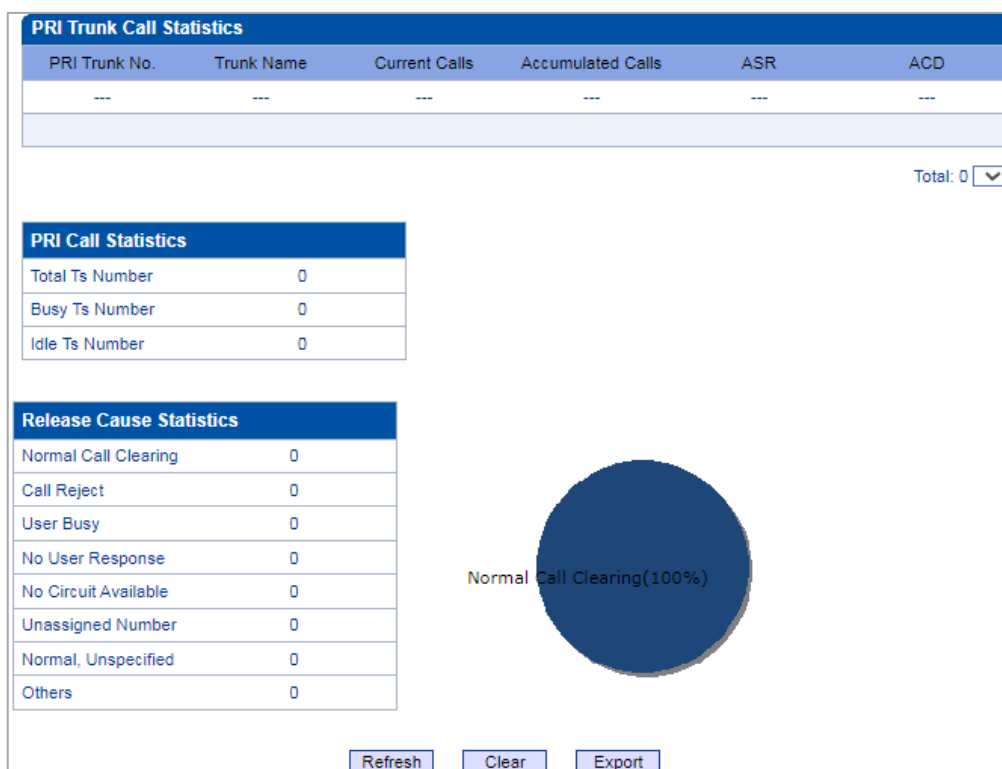

4.4.9 SS7 Call Statistics

On the **SS7 Call Statistics** interface, information about SS7 calls and statistics about call release causes are displayed.

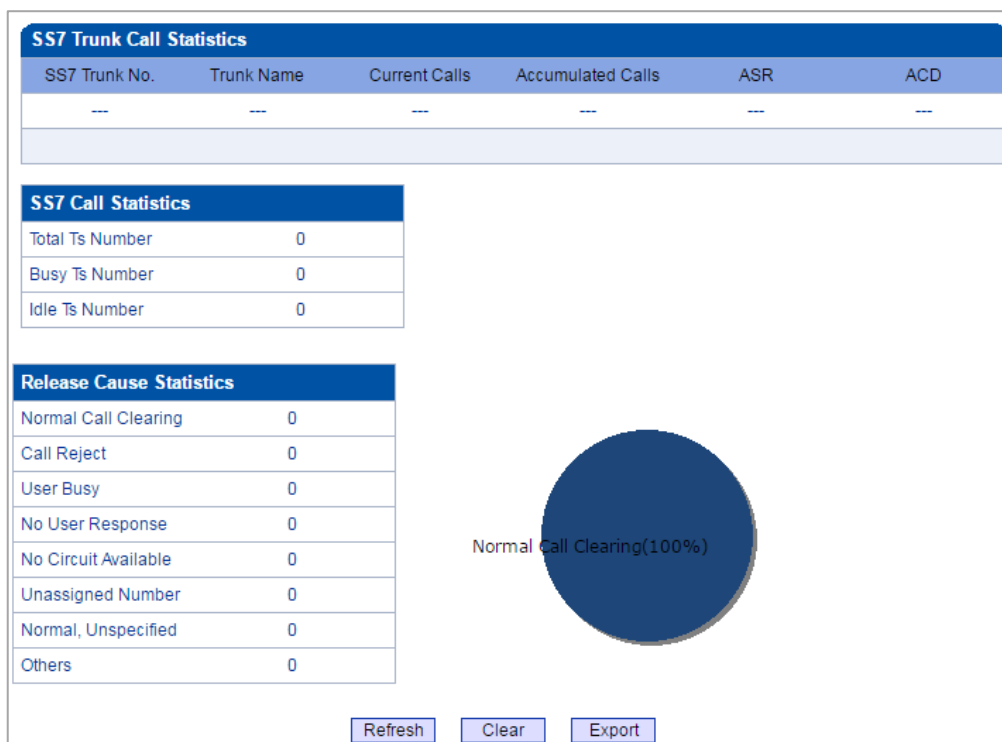

4.4.10 R2 Call Statistics

On the **R2 Call Statistics** interface, information about R2 calls and statistics about call release causes are displayed.

R2 Trunk Call Statistics					
R2 Trunk No	Trunk Name	Current Calls	Accumulated Calls	ASR	ACD
---	---	---	---	---	---

R2 Call Statistics	
Total Ts Number	0
Busy Ts Number	0
Idle Ts Number	0

Release Cause Statistics	
Normal Call Clearing	0
Call Reject	0
User Busy	0
No User Response	0
No Circuit Available	0
Unassigned Number	0
Normal, Unspecified	0
Others	0

NOTE: When calls exist, Not allow to clear call stat!

4.4.11 SIP Call Statistics

On the **SIP Call Statistics** interface, information about SIP calls and statistics about call release causes are displayed.

SIP Trunk Call Statistics						
Trunk No.	Trunk Name	Current Calls	Accumulated Calls	ASR	ACD	InCaps
0	5.230	0	0	100%	0	---
1	Ag2.150	0	0	100%	0	---
---	Total	0	0	---	---	0

Release Cause Statistics	
Normal Call Clearing	0
Temporarily Unavailable	0
Forbidden	0
Not Found	0
Busy Here	0
Internal Server Error	0
Server Time Out	0
Service Unavailable	0
Others	0

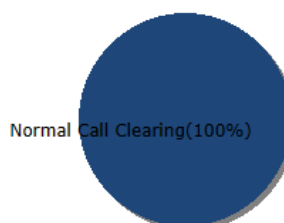

4.4.12 Radius Statistics

On the Radius Statistics interface, display information about the status of the master/slave server, sending request statistics, radius server non-response statistics, overload statistics, etc.

Radius Statistics									
Svr0	Svr1	Total Req	Success	Fail	No R.	Bad R.	Overload	OverBuffer	Total Sent
Active	Active	0	0	0	0	0	0	0	0

[Refresh](#)

4.4.13 Record Statistics

On the Record Statistics interface, display information about the server status, the current number of recordings, the number of non-response recordings, the total of recordings started, and the statistics of non-response reasons, etc.

Record Statistics							
Server Stat	Current Records	No Responses	Server Return Error	Start	StartAck	Stop	StopAck
Not Config	0	0	0	0	0	0	0

NoRsp Statistics	
Link Dect NoRsp Cnt	0
Start Time Out Cnt	0
Rel Call Before StartAck	0
Stop Time Out Cnt	0

[Refresh](#) [Reset](#)

4.4.14 Monitoring Information

The power supply voltage and fan speed can be viewed in the monitoring information interface.

Monitoring Information	
Voltage	
Power 0	0.0 V
Power 1	11.6 V
Fan0 Speed	
Fan 0	2006 r/min
Fan 1	2031 r/min
Fan 2	2070 r/min
Fan 3	2069 r/min
Fan 4	2019 r/min
Fan 5	2035 r/min
Fan1 Speed	
Fan 0	1969 r/min
Fan 1	1978 r/min
Fan 2	1983 r/min
Fan 3	2051 r/min
Fan 4	2037 r/min
Fan 5	2014 r/min

[Refresh](#)

4.5 Network Parameter Config

This menu manages the necessary network configuration parameters for the device, including network configure, static IP routing table, ACL management settings, and VLAN configuration. This menu and its sub-menus can configure the IP addresses of the device's service and management ports, ACL security access and VLAN parameters. Because the access rights of the interface are involved, before implementing the above settings, users are required to confirm the rights of the service port and management port, as well as the ACL address and other necessary information to avoid the situation that the device cannot be accessed due to wrong configuration.

4.5.1 Network Config

Generally, it's necessary to modify the default IP address of GE1 according to actual network conditions, and then modify the IP address of PC to make it at the same network segment with the IP address of GE1. After completing the configurations, you need to restart the MTG5000-64E1 device for the changes to take effect.

Network Configuration

Service Ethernet Interface(GE1)	
IP Address	<input type="text" value="172.28.26.50"/>
Subnet Mask	<input type="text" value="255.255.0.0"/>
Default Gateway	<input type="text" value="172.28.1.1"/>
Work Mode	<input type="text" value="Auto Negotiation"/>
Management Ethernet Interface(GE0)	
IP Address	<input type="text" value="192.168.11.1"/>
Subnet Mask	<input type="text" value="255.255.255.0"/>
Default Gateway	<input type="text" value="0.0.0.0"/>
Work Mode	<input type="text" value="Auto Negotiation"/>
DNS Server	
Primary DNS Server	<input type="text" value="8.8.8.8"/>
Secondary DNS Server	<input type="text" value="0.0.0.0"/>
Default Gateway	
Interface	<input type="text" value="GE1"/>

NOTE: The device must restart to take effect.

Belong to	Parameter	Explanation
GE1 Port	IP Address	The IP address of GE1, default value is 192.168.1.111
	Subnet Mask	Subnet mask of GE1
	Default Gateway	The IP address of network gateway
	Work Mode	Include Auto Negotiation, 1000M/Full-Duplex, 100M/Full-Duplex, 100M/Half-Duplex. Full-Duplex: Communication in both directions simultaneously. Half-Duplex: Communication only in one direction.
GE0 Port	IP Address	The IP address of GE0, default value is 192.168.11.1
	Subnet Mask	Subnet mask of GE0
	Default Gateway	The IP address of network gateway
	Work Mode	Same with Work Mode of GE1
DNS	Primary DNS Server	The IP address of the primary DNS server
	Secondary DNS Sever	The IP address of the secondary DNS server. It is optional to fill in.
Default Gateway	Interface	Configuration of the device's default gateway, user can choose GE1/GE0.

Note: The IP address of GE1 and that of GE0 cannot be at the same network segment.

4.5.2 Static IP Routing Table

Static IP Routing Table		
Destination Network	Subnet Mask	Gateway
---	---	---

Static IP Routing Table Add	
Destination Network	<input type="text"/>
Subnet Mask	<input type="text"/>
Gateway	<input type="text"/>

Parameter	Explanation
Destination Network	Reachable IP address or network segment address
Subnet Mask	The address of subnet mask
Gateway	The address of gateway which is at the same network segment of the default gateway of the MTG5000-64E1 device

4.5.3 ACL White List

The screenshot shows the 'ACL White List' configuration interface. At the top, there is a header 'ACL White List'. Below it is a table with two columns: 'Ip Addr' and 'Access Type'. The table is currently empty. Below the table, there are three buttons: 'Add', 'Delete', and 'Modify'.

The screenshot shows the 'Add ACL White List' dialog box. It has a header 'Add ACL White List'. Below the header, there are two input fields: 'Ip Addr' and 'Access Type'. The 'Access Type' dropdown menu is currently set to 'Web'. At the bottom of the dialog, there are three buttons: 'OK', 'Reset', and 'Cancel'.

Parameter	Explanation
IP Address	The IP address that is to visit the MTG5000-64E1 device
Access Type	Choose web, telnet or web telnet

4.5.4 ACL Control Config

The screenshot shows the 'ACL Control Config' configuration page. It has a header 'ACL Control Config'. Below the header, there are two dropdown menus: 'Web Access Control' and 'Telnet Access Control'. Both dropdown menus are currently set to 'Enable'. At the bottom of the page, there is a 'save' button.

Parameter	Explanation
Web Access Control	If this parameter is enabled, those IP addresses that are not on the ACL whitelist cannot visit the MTG5000-64E1 device through Web.
Telnet Access	If this parameter is enabled, those IP addresses that are not on

Control	the ACL whitelist cannot visit the MTG5000-64E1 device through Telnet.
---------	--

Note: You need to disable Web access control and Telnet access control, otherwise, the MTG5000-64E1 device cannot be visited through Web or Telnet.

4.5.5 VLAN Config

GE1 VLAN

VLAN 1

Signal Media

802.1Q VLAN1 ID(0 - 4095)

802.1P Priority(0 - 7)

IP Address

Subnet Mask

Default Gateway

Primary DNS Server

Secondary DNS Server

VLAN1 MTU

Enable

Management

3
6

Enable

Enable

GE0 VLAN

VLAN 1 Enable

VLAN 2 Enable

VLAN 3 Enable

Parameter	Explanation
802.1Q VLANx ID(0 - 4095)	The ID of VLAN of MTG5000-64E1
802.1P Priority (0 - 7)	The priority of sending data. The larger digit, the higher priority.
IP Address	The IP address of the MTG5000-64E1 device in the VLAN
Subnet Mask	The subnet mask address of the MTG5000-64E1 device in the VLAN
Default Gateway	The default gateway of the VLAN
Primary DNS Server	The IP address of a Primary DNS Server
Secondary DNS Server	The IP address of a secondary DNS Server
VLANx MTU	The maximum size of package allowed to access VLAN

Note: You need to restart the MTG5000-64E1 device after finishing the configurations of VLAN.

4.6 PRI Config

This menu manages the parameters related to the PRI. Before using the PRI, users need to check whether the parameters match those of the remote end. Incorrectly matched parameters can cause signaling or voice problems. The PRI parameters include the call number attribute settings and other transmission settings, as well as the PRI D-channel settings, protocol type and interface parameter attributes for each ports, which can cause signaling problems with PRI if the parameters are incorrectly set.

4.6.1 PRI Parameter

Configure PRI parameters according to actual data which are provided by telecom operators.

PRI Parameter

Calling Party Numbering Plan	ISDN/Telephony numbering plan ▼
Calling Party Number Type	Unknown ▼
Screening Indicator for Displaying Caller Number	User-provided, not screened ▼
Screening Indicator for No Displaying Caller Number	User-provided, not screened ▼
Called Party Numbering Plan	ISDN/Telephony numbering plan ▼
Called Party Number Type	Unknown ▼
Information Transfer Capability	Speech ▼
Send Dial Tone	Disable ▼
Alert Compensation	Enable ▼
Send Status when IE Element Incompatible	Disable ▼
Reset to default configuration	<input type="button" value="Reset"/>

Parameter	Options
Calling Party Numbering Plan	Include 'ISDN/Telephony Numbering Plan', 'Data Numbering Plan', 'Telex Numbering Plan', 'National Standard Numbering Plan', 'Private Numbering Plan' and 'Unknown'.
Calling Party Number Type	Include 'International Number', 'National Number', 'Network Specific Number', 'Subscriber Number', 'Abbreviated Number' and 'Unknown'.
Screening Indicator for Displaying Caller Number	Include 'User-provided, not screened', 'User-provided, verified and passed', 'User-provided, verified and failed', 'Network-provided'
Screening Indicator for No Displaying Caller Number	Include 'User-provided, not screened', 'User-provided, verified and passed', 'User-provided, verified and failed', 'Network-provided'
Called Party Numbering Plan	Include 'ISDN/Telephony Numbering Plan', 'Data Numbering Plan', 'Telex Numbering Plan', 'National Standard Numbering Plan', 'Private Numbering Plan' and 'Unknown'.
Called Party Number Type	Include 'International Number', 'National Number', 'Network Specific Number', 'Subscriber Number', 'Abbreviated Number' and 'Unknown'.
Information Transfer Capability	Include 'Speech' and '3.1 kHz audio'
Send Dial Tone	In the mode of Overlap Receiving, the setup message is received to reply to the setup ack message, and a dial tone is sent to the PSTN side to prompt the caller to dial the number
Alert Compensation	When enabled, the device sends PROCEEDING and ALERTING messages and then sends CONNECT messages
Send Status when IE Element incompatible	When the MTG receives an MT_SETUP message but some IE units have problems, the MTG sends an MT_STATUS message to the other side, and if the other side cannot process the MT_STATUS message it will send an MT_RELEASE message to release the call.

4.6.2 PRI Trunk

On the PRI Trunk interface, you can configure PRI trunks for PRI calls. The statuses of PRI Trunks can be seen at the Status & Statistics → PSTN Trunk Status interface.

Click the Add button, and you can add a PRI trunk. If you want to delete or modify the information of a PRI trunk, select the checkbox on the left of the trunk, and then click the Delete button or the Modify button.

PRI Trunk								
	Trunk No.	Trunk Name	Channel ID	D-Channel	E1/T1 Port No.	Protocol	Switch Side	Alerting Indication
<input type="checkbox"/>	1	pri0	0	Enable	15	ISDN	User Side	ALERTING

Parameter	Explanation
Trunk No.	Trunk No. starts from 0 to 19, it means you can establish 20 PRI trunks at most. The trunk No. is decided by the No. of the E1/T1 port linked to the trunk. But if D-channel is not enabled for a trunk, the No. of the trunk must be the same with a trunk under which D-channel has been enabled.
Trunk Name	The trunk name is used to distinguish the trunk from other trunks.
Channel ID	The ID of the channel selected for the PRI trunk. The channel ID is used for the switch to identify a PRI trunk in case that the Trunk No. of two trunks are the same.
D-Channel (Delta Channel)	The channel used to carry control information and signaling information
E1/T1 Port No.	The No. of E1/T1 port linked to the PRI trunk
Protocol	Support two protocols: ISDN and QSIG. Default value is ISDN.
Switch Side	The E1/T1 port of the PRI trunk is taken as User Side or Network Side.
Alerting Indication	Include Alerting and Progress Alerting: Play ring-back tone when receiving alerting signal Progress: Play ring-back tone when receiving progress signal

4.7 SS7 Config

This menu manages the necessary parameters related to SS7. If users are using SS7, they need to configure the parameters in this menu. Specific submenu parameter settings include SS7 Parameters, SS7 Trunk, SS7 MTP Link, SS7 CIC, SS7 Link Set, and SS7 CIC Maintain Before configuring the necessary SS7 parameters, users need to know the related SS7 trunk, SPC, OPC, DPC and other core parameters. A mismatch with the parameters of the remote device can lead to problems such as link signaling failure and other call problems.

4.7.1 SS7 Parameter

SS7 Parameter	
Auto Reset Circuit	Enable
Generic Number	Disable
Maunal Down	Disable
Logic STP	Disable
Alert Compensation	Enable
INR	Disable
Incoming Charge Number	Disable
Outgoing Charge Number	Disable
Reset to default configuration	Reset

Parameter	Explanation
Auto Reset Circuit	The circuit reset/circuit group reset message is used to reset the circuit of both parties to the initial idle state; this message is related to the circuit, so you can use this message to check whether the other party is configured with the corresponding CIC.
Generic Number	ISUP outgoing calls, when there is a forwarding/original called number, the calling number is coded in the generic number, and the original called number is coded in the calling number field.
Manual Down	When enabled, the SS7 link will be in the Layer 2 link state, and the port ISDN/SS7 signaling alarms.
Logic STP	The SS7 signaling working mode is divided into direct link and quasi-direct link. The quasi-direct link means that the No. 7 signaling message is transmitted through two or more serial signaling links, and one or more STPs are passed in the middle. In the case of quasi-direct link, logical STP needs to be enabled.
Alert Compensation	The device does not receive the <i>1&X</i> message, but directly receives <i>200 OK</i> . When the ringing compensation is enabled, the device sends ACM to the PSTN side to compensate, and then sends ANM.
INR	When enabled, MTG sends INR after receiving IAM without calling number.
Incoming Charge Number	ISUP+ANSI SS7 trunk, when the incoming charge number is enabled, there will be a <i>charge number</i> field in the IAM message received, and the <i>P-Charge-Info</i> header will be carried in the <i>invite</i> message sent by the device.
Outgoing Charge Number	ISUP+ANSI SS7 trunk, when the outgoing charge number is enabled, the received <i>invite</i> message will come with the <i>P-Charge-Info</i> header ,and the IAM message sent by the device will come with the <i>charge number</i> field.

4.7.2 SS7 Trunk

On the **SS7 Config** → **SS7 Trunk** interface, you can configure SS7 trunks for SS7 calls. The status of SS7 Trunks can be seen at the **Status & Statistics** → **PSTN Trunk Status** interface.

SS7 Trunk									
Trunk No.	Trunk Name	Protocol	Protocol Type	SPC Format	OPC	DPC	Network Indicator	Sending SLTM	
<input type="checkbox"/>	0	ss7-2	ITU	ISUP	HEX	5	7	National Network	Enable

Parameter	Explanation
Trunk No.	The No. of the SS7 trunk. Generally, one SS7 trunk is for one DPC.
Trunk Name	The trunk name is used to distinguish the trunk from other trunks.
Protocol	SPC types: ITU-T (14 bit), ANSI (24 bit), ITU-CHINA (24 bit) SPC: Signaling Point Code
Protocol Type	ISUP (ISDN User Part) and TUP (Telephone User Part)
SPC Format	SPC: Signaling Point Code SPC format includes Hex (Hexadecimal system) and ITU point code structure (decimal system)
OPC	OPC: Original Point Code The signaling point code of MTG5000-64E1, which is generally assigned by telecom operators.
DPC	DPC: Destination Point Code The signaling point code of the peer device, which is generally assigned by telecom operators.
Network Indicator	Include International Network, International Spare, National Network and National Spare. Default value is National Network, which is mainly used in China, America, and Japan.
Sending SLTM	Whether to send signaling link test message.
Link Set No.	The SS7 link set bundled with the SS7 trunk.

4.7.3 SS7 MTP Link

On the **SS7 Config** -> **SS7 MTP Link** interface, click the Add button, and you will see the following interface. On the interface, you can select an E1/T1 port for an existing trunk and establish two links between them.

SS7 MTP Link Add	
No.	NaN
Trunk No.	
Link No.	0
Signaling Link Code	
E1/T1 Port No.	
Channel No.	16
Caller Type	Not Configured
Callee Type	Not Configured
OrgCallee Type	Not Configured
Numbering Plan	ISDN
Calling Presentation	Allowed
Screening indicator	User Provided
Called Stop sending	Disable
Calling Stop sending	Disable
Link Mode	Default
Binding Slave TG	None

Parameter	Explanation
No.	
Trunk No.	The No. of the SS7 trunk
Link No.	Each SS7 trunk supports two links which share the loading equally. If one link malfunctions, the other link will automatically bear all the loading until the faulty link is restored.
Signaling Link Code	If the Link No. of the trunk cannot match with that of the peer device, the SS7 trunk will be linked to the peer device according to signaling link code.
E1/T1 Port No.	The No. of E1/T1 port linked to the SS7 trunk
Channel No.	The No. of the channel under which signal is transmitted. Default value is 16.
Caller Type	The type of the caller number. Options include 'Not Configured', 'Subscriber', 'International' and 'National'.
Callee Type	The type of the called number. Options include 'Not Configured', 'Subscriber', 'International' and 'National'.
OrgCallee Type	The type of the original called number in case of number manipulation. Options include 'Not Configured', 'Subscriber', 'International' and 'National'.
Numbering Plan	Options include 'ISDN', 'Data', 'Telex' and 'Private'.
Calling Presentation	If 'Allowed' is selected, the calling number will be presented. If 'Restricted' is selected, the calling number will not be presented. If 'Not Config' is selected, the parameter does not work.

Screening Indicator	Options include “User Provided” and “Network Provided”.
Called Stop sending	‘Stop Sending’ is an end mark. If ‘Yes’ is selected for ‘Called Stop Sending’, it means there will be an end mark following the called number.
Calling Stop Sending	‘Stop Sending’ is an end mark. If ‘Yes’ is selected for ‘Calling Stop Sending’, it means there will be an end mark following the calling number.
Link Mode	Default/Logical only, logical only means quasi-direct connection
Binding Slave TG	When SS7 master-slave TG is enabled, the slave TG needs to bind the shared TG number.

4.7.4 SS7 CIC

On the **SS7 Config** -> **SS7 CIC** interface, click the Add button, and you will see the following interface. You can determine which channels will be used by an SS7 trunk on the interface.

Procedures for adding SS7circuit that only involves an E1/T1 port:

Step 1: Click **Add** on the **SS7 CIC** interface.

Step 2: Select a trunk and an E1/T1 port. (Trunk 0 and Port 1 are taken as example in the following figure

Note:

As there are 32 channels (from 0 to 31) for one E1/T1 port, so the value for **Count** is 32. When start E1/T1 port is the same with end E1/T1 port, it means only one E1/T1 port is connected to the SS7 trunk.

Parameter	Explanation
Trunk No.	The No. of the SS7 trunk
Start E1/T1 Port No.	The No. of the start E1/T1 port
End E1/T1 Port No.	The No. of the end E1/T1 port
Start Channel	When the start E1/T1 port is also the end E1/T1 port, it's required to set the start channel, and the channels starting from the set channel to the No.31 channel of the E1/T1 port will be used by the SS7 trunk.
Start CIC No.	CIC: Circuit Identification Code The CIC No. of the start channel, which is generally 0, 32, 64, 96, 128, 160, 192, 224, 256, 288, 320, 352, 384, 416, 448...
Count	The total number of the channels used by the SS7 trunk

Step3: Click OK. And then you can see the following data on the SS7 CIC interface.

SS7 Circuit					
	Trunk No.	E1/T1 Port No.	Start Channel	Start CIC No.	Count
<input type="checkbox"/>	0	1	0	0	32

➤ Procedures for adding SS7circuit that involves multiple E1/T1 ports:

Step 1: Click Add on the SS7 CIC interface.

Step 2: Select a trunk and E1/T1 ports. (Trunk 1, Port 0, Port1 and Port 2 are taken as example in the following figure.

SS7 Circuit Add

Trunk No.

Start E1/T1 port No.

End E1/T1 port No.

Start CIC No.

Note:

If multiple E1/T1 ports are involved, it defaults that all the 32 channels of each E1/T1 port involved are used by the SS7 trunk.

Step3: Click OK. And then you can see the following data on the SS7 CIC interface.

SS7 Circuit					
	Trunk No.	E1/T1 Port No.	Start Channel	Start CIC No.	Count
<input type="checkbox"/>	1	0	0	0	32
<input type="checkbox"/>	1	1	0	32	32
<input type="checkbox"/>	1	2	0	64	32

4.7.5 SS7 Link Set

Two signaling points (SSP, SCP and STP) are connected by a MTP link or links. Those links can be grouped into a set. In a link set, the first MTP link has the highest priority. When the first MTP link is faulty, the next link in the set will be chosen.

Ss7 Link Set	
Link Set No.	MTP Link No.
---	---

Ss7 Link Set Add	
Link Set No.	<input type="text" value="0"/>
MTP Link No.	<input type="text" value="None"/>

Parameter	Explanation
Link Set No.	The No. of the SS7 link set. There are 8 link set allowed (from 0 to 7).
MTP Link No.	The No. of MTP link that has been configured.

4.7.6 SS7 CIC Maintain

There are two objects to be maintained for SS7 CIC, namely E1/T1 ports and channels. Select E1/T1 on the right of Operation Mode, and the following interface will be displayed.

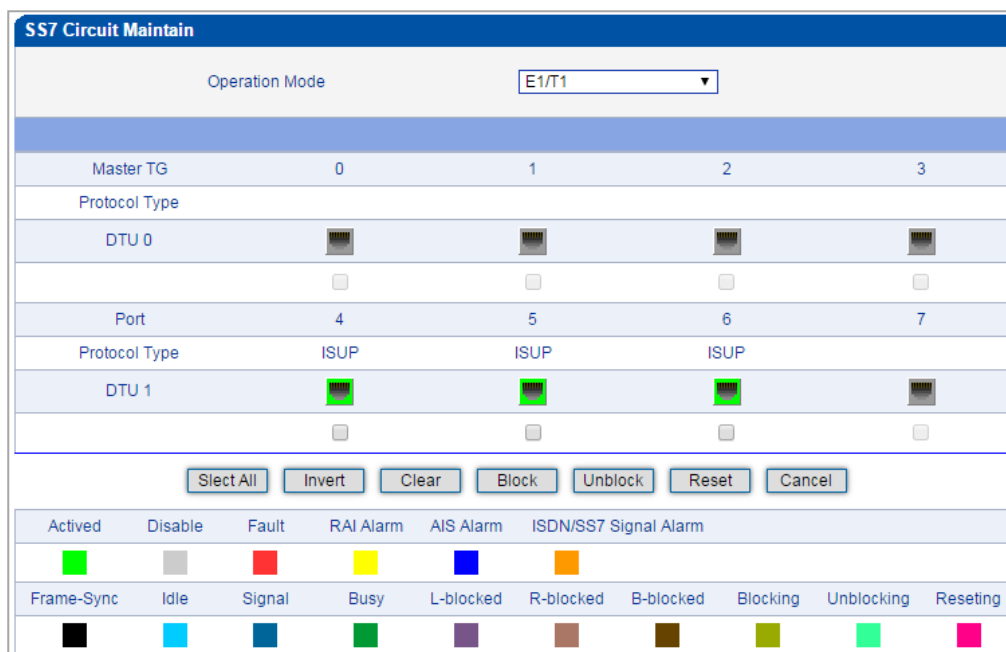

Parameters	Explanation
Operation Mode	E1/T1
Port	The No. of E1/T1 port
Protocol Type	ISUP or TUP
DTU	The No. of DTU which the E1/T1 ports belong to
Status	The E1/T1 ports have 16 statuses, including Activated, Disabled, Fault, RAI Alarm, AIS Alarm, ISDN/SS7 Signal Alarm, Frame-Sync, Idle, Signal, Busy, L-block, R-blocked, B-blocked, Blocking, Unblocking and Resetting. The meaning of each status, please make reference to 4.4.3.

Meanwhile, you can carry out maintenance on the E1/T1 ports through the following buttons:

Select All, Invert, Clear, Block, Unblock, Reset and Cancel.

Select **Channel** on the right of **Operation Mode**, and then select an E1/T1 port, the channels of the E1/T1 port and their statuses are displayed.

SS7 Circuit Maintain

Operation Mode Channel

Current Port Status

Channel	0	1	2	3	4	5	6	7	8	9	10	11	12	13	14	15
Cic No.																
Status																
	<input type="checkbox"/>	<input type="checkbox"/>	<input type="checkbox"/>	<input type="checkbox"/>	<input type="checkbox"/>	<input type="checkbox"/>	<input type="checkbox"/>	<input type="checkbox"/>	<input type="checkbox"/>	<input type="checkbox"/>	<input type="checkbox"/>	<input type="checkbox"/>	<input type="checkbox"/>	<input type="checkbox"/>	<input type="checkbox"/>	<input type="checkbox"/>

Channel	16	17	18	19	20	21	22	23	24	25	26	27	28	29	30	31
Cic No.																
Status																
	<input type="checkbox"/>	<input type="checkbox"/>	<input type="checkbox"/>	<input type="checkbox"/>	<input type="checkbox"/>	<input type="checkbox"/>	<input type="checkbox"/>	<input type="checkbox"/>	<input type="checkbox"/>	<input type="checkbox"/>	<input type="checkbox"/>	<input type="checkbox"/>	<input type="checkbox"/>	<input type="checkbox"/>	<input type="checkbox"/>	<input type="checkbox"/>

Activated	Disable	Fault	RAI Alarm	AIS Alarm	ISDN/SS7 Signal Ala...				
■	■	■	■	■	■				
Frame-Sync	Idle	Signal	Busy	L-blocked	R-blocked	B-blocked	Blocking	Unblocking	Resetting
■	■	■	■	■	■	■	■	■	■

Notes: L-Blocked -- Local Blocked, R-Blocked -- Remote Blocked, B-Blocked -- Both Sides Blocked

Parameter	Explanation
Operation Mode	Channel
Current Port	The No. of the current E1/T1 port
Channel	The No. of channels
CIC No.	The CIC No. of channels
Status	The statuses of channels, including Activated, Disabled, Fault, RAI Alarm, AIS Alarm, ISDN/SS7 Signal Alarm, Frame-Sync, Idle, Signal, Busy, L-block, R-blocked, B-blocked, Blocking, Unblocking and Resetting.

Meanwhile, you can carry out maintenance on the channels of E1/T1 ports through the following buttons:

Select All, Invert, Clear, Block, Unblock, Reset and Cancel.

4.8 R2 Config

This menu manages the necessary parameters associated with R2. If the user uses R2, user needs to configure the relevant trunks and parameters in these sub-menus. The submenus include R2 parameters, R2 trunks and R2 settings. Users need to select the corresponding port and set the R2 parameters supported by the related operator. Mismatches between the set parameters and the remote parameters can cause signaling and calling problems.

4.8.1 R2 Param

This function is used to control the interaction of R2 trunk signaling in different countries. It mainly configures the parameters of Group I, Group II, Group A, Group B, and Group C.

R2 Param										
	Param ID	Description	CDbits	Req Next DNIS	Request Next ANI	Request Category	DNIS End	ANI End	Adress Complete	Answer Signal
<input type="checkbox"/>	0	ITU	01	A-1	A-5	A-5	I-15	I-15	A-3	Call with charge
<input type="checkbox"/>	1	Argentina	01	A-1	A-5	A-5	INVALID	I-12	A-3	Call with charge
<input type="checkbox"/>	2	Brazil	01	A-1	A-5	A-5	INVALID	I-15	A-3	Call with charge
<input type="checkbox"/>	3	China	11	A-1	A-1	A-6	INVALID	I-15	A-3	Call with charge

R2 Param Add	
Config Mode	Custom
Param ID	6
Description	
CDbits	01
Calling Party Category	National subscriber
Answer tone	Call with charge
Double Answer	Disable
Seize Timer (ms)	5000
Protect Timer (ms)	300000
Receive Timer (ms)	5000
Wait Response Timer (ms)	3000
MF Off Timer (ms)	3000
Wait Release Timer (ms)	3000
Double Answer Timer (ms)	400
Group I:	
DNIS end flag	I-15
ANI end flag	I-15
Caller number restricted	I-12
Group II:	
National subscriber	II-1
National priority subscriber	II-2
International subscriber	II-7
International priority subscriber	II-9
Collect call	INVALID
Group A:	
Address Complete	A-3
Request next DNIS	A-1
Request next ANI	A-5
Request category	A-5
Request Change to Group C	INVALID
Request last DNIS but one	A-2
Request last DNIS but two	A-7
Request last DNIS but three	A-8
Request Last Digit Again	A-8
Repeat All DNIS Digit	A-8
Group B:	
Unallocated number	B-5
User busy	B-3
Special tone	B-2
Line out of order	B-2
Call with charge	B-6
Call without charge	B-6
Group C (for Mexico):	
Request Next ANI	C-1
Request All DNIS and change to Group A	C-2
Address Complete	C-3
Network Congestion	C-4
Request next DNIS and change back to Group A	C-5
Request Last DNIS and change back to Group A	C-6

OK Reset Cancel

Parameter	Explanation
Config Mode	Options: typical and custom. All parameters can be configured in custom mode, and only part of the parameters of group I, group A, and group B can be configured in typical mode
Param ID	Up to 100 R2 parameters can be configured
CDbits	01 means other, 11 means china
Calling Party Category	In the signaling interaction, before sending the calling number, after receiving the request category, and after sending the calling, switching to group II will send the calling user category
Answer tone	Call with charge/Call without charge/Special tone, switch to group B after number interaction and then send, can be configured in group B.
Double Answer	When enabled, the called party picks up the phone and respond <i>answer</i> and then <i>clear ack</i> and then <i>answers</i> to continue. When disabled, respond <i>answer</i> , and then <i>clear</i> after the called party picks up the phone.
Seize Timer(ms)	The default is 5000ms.
Protect Timer (ms)	The default is 30,000 ms. A timeout timer when no response is received for an inter-register signaling sent during an inter-register signaling interaction.
Receive Timer (ms)	The default is 5,000 ms. A timeout timer when no response is received for sending a request for the next bit of inter-register signaling and not received number during an inter-register signaling interaction.
Wait Response Timer (ms)	The default is 5,000 ms.
MF Off Timer (ms)	The default is 3000 ms. After the control device sends an inter-register signaling, no mutual control signal is received from the other side, and the current inter-register is stopped after the timeout, so that the PSTN side detects the signal until the signal ends.
Wait Release Timer (ms)	The default is 5,000 ms.
Double Answer Timer (ms)	The default is 5,000 ms, the time interval between the two <i>answer</i> sent.
Group I	
DNIS end flag	End flag after the called number has been sent
ANI end flag	End flag after the calling number has been sent
Caller number restricted	When an invite message without a caller's number is received, the callee will no longer request a caller's number, and the

	caller will no longer send it.
Group II	
National subscriber	Configure the inter-register signaling sent by the calling party (whose type is national subscriber)
National priority subscriber	Configure the inter-register signaling sent by the calling party (whose type is national priority subscriber)
International subscriber	Configure the inter-register signaling sent by the calling party (whose type is international subscriber)
International priority subscriber	Configure the inter-register signaling sent by the calling party (whose type is international priority subscriber)
Collect call	Configure the inter-register signaling sent by the calling party (whose type is collect call)
Group A	
Address Complete	After sending the calling and called numbers, the called party sends the signaling request to group II
Request next DNIS	The called number sends the signaling to request the next called number before receiving the called number end flag
Request next ANI	The called party sends the signaling to request the next calling number before receiving the calling number end flag
Request Change to Group C	After the calling number is sent, the called party sends the signaling change to group C
Request last DNIS but one	Send a request to the last called number on the PSTN side
Request last DNIS but two	Send a request to the last two called numbers on the PSTN side
Request last DNIS but three	Send a request to the last three called numbers on the PSTN side
Request Last Digit Again	PSTN side requests the last number again
Repeat All DNIS Digit	PSTN side requests to repeat all called numbers
Group B	
Unallocated number	Send this signal to end the call when the called party responds with 404
User Busy	Send this signal to end the call when receiving the 486 from the called party
Special tone	Configure inter-register signaling for the line type of special tone
Line out of order	Send this signal to end the call when the line is abnormal
Call with charge	Configure inter-register signaling for the line type of call with charge

Call without charge	Configure inter-register signaling for the line type of call without charge
Group C (for Mexico)	
Request Next ANI	After switching to group C, the callee sends the signaling request to the next called number
Request All DNIS and change to Group A	Request all called numbers and go to group A to send the signaling
Address Complete	After sending the calling and called numbers, the called party sends the signaling request to group II
Network Congestion	Send this signaling when there is network congestion
Request next DNIS and change back to Group A	Request the previous called number and forward back to group A to send the signaling
Request Last DNIS and change back to Group A	Request the last called number and forward back to group A to send the signaling

4.8.2 R2 Trunk

R2 Trunk			
Trunk No.	Trunk Name	E1 Port No.	Protocol Param
---	---	---	---

R2 Trunk Add	
Trunk No	<input type="text" value="0"/>
Trunk Name	<input type="text"/>
E1 Port No.	<input type="text" value="0"/>
Protocol Param	<input type="text" value="0 <ITU>"/>

Parameter	Explanation
E1 Port No.	E1 port number not yet configured
Protocol Param	Configured R2 protocol parameters

4.8.3 R2 Setting

R2 Setting	
MF Gain From PSTN	1dB
MF Gain To PSTN	4dB
Reset to default configuration	Reset
Save	

Parameter	Explanation
MF Gain From PSTN	The gain of MF call in
MF Gain To PSTN	The gain of MF call out

4.9 PSTN Group Config

This menu manages the setting of configuration parameters related to PSTN group. When using this device, users need to configure some sub-menus in this interface menu first. The submenus include: clock source, E1/T1 parameters, port number, codec group, PSTN rule group and other related parameters. In general, users need to first confirm the clock source obtaining method, configure E1 or T1 parameters according to different country settings, set the corresponding ports and grouping rules, etc.

4.9.1 Clock Source

When clock source is produced by the local crystal chip of MTG5000-64E1, it is regarded as local clock source. When clock source is obtained from the data received by E1/T1 ports, it is regarded as remote clock source. Each E1/T1 port can obtain one clock source.

Clock Source Config

DTU0 Clock Source Mode	<input checked="" type="radio"/> Remote <input type="radio"/> Local
Remote Clock Source Port	<input type="text" value="0"/>
DTU1 Clock Source Mode	<input type="radio"/> Remote <input checked="" type="radio"/> Local
DTU2 Clock Source Mode	<input checked="" type="radio"/> Remote <input type="radio"/> Local
Remote Clock Source Port	<input type="text" value="0"/>
DTU3 Clock Source Mode	<input checked="" type="radio"/> Remote <input type="radio"/> Local
Remote Clock Source Port	<input type="text" value="0"/>
DTU4 Clock Source Mode	<input checked="" type="radio"/> Remote <input type="radio"/> Local
Remote Clock Source Port	<input type="text" value="0"/>
DTU5 Clock Source Mode	<input checked="" type="radio"/> Remote <input type="radio"/> Local
Remote Clock Source Port	<input type="text" value="0"/>
DTU6 Clock Source Mode	<input checked="" type="radio"/> Remote <input type="radio"/> Local
Remote Clock Source Port	<input type="text" value="0"/>
DTU7 Clock Source Mode	<input checked="" type="radio"/> Remote <input type="radio"/> Local
Remote Clock Source Port	<input type="text" value="0"/>
DTU8 Clock Source Mode	<input checked="" type="radio"/> Remote <input type="radio"/> Local
Remote Clock Source Port	<input type="text" value="0"/>
DTU9 Clock Source Mode	<input checked="" type="radio"/> Remote <input type="radio"/> Local
Remote Clock Source Port	<input type="text" value="0"/>
DTU10 Clock Source Mode	<input checked="" type="radio"/> Remote <input type="radio"/> Local
Remote Clock Source Port	<input type="text" value="0"/>
DTU11 Clock Source Mode	<input checked="" type="radio"/> Remote <input type="radio"/> Local
Remote Clock Source Port	<input type="text" value="0"/>
DTU12 Clock Source Mode	<input checked="" type="radio"/> Remote <input type="radio"/> Local
Remote Clock Source Port	<input type="text" value="0"/>
DTU13 Clock Source Mode	<input checked="" type="radio"/> Remote <input type="radio"/> Local
Remote Clock Source Port	<input type="text" value="0"/>
DTU14 Clock Source Mode	<input checked="" type="radio"/> Remote <input type="radio"/> Local
Remote Clock Source Port	<input type="text" value="0"/>
DTU15 Clock Source Mode	<input checked="" type="radio"/> Remote <input type="radio"/> Local
Remote Clock Source Port	<input type="text" value="0"/>

Parameter	Explanation
Select Clock Source Mode	If Remote is selected, clock source is produced by crystal chip; if local is selected, clock source is obtained from the data received by E1/T1 port.
Select Remote Clock Source Port	The No. of the E1/T1 port from which clock source is obtained.
Automatic Clock Protect	Clock source is protected automatically indicates an internal clock source mechanism is enabled.

4.9.2 E1/T1 Parameter

Select the checkbox on the left of an E1/T1 port, and click the Modify button to modify E1/T1 parameters.

E1/T1 Parameter						
	Port No.	Work Mode	PCM Mode	Frame Format	Line Code	Line Built Out
<input type="checkbox"/>	0	E1	ALAW	DF	HDB3	Short Haul
<input type="checkbox"/>	1	E1	ALAW	DF	HDB3	Short Haul
<input type="checkbox"/>	2	E1	ALAW	DF	HDB3	Short Haul
<input type="checkbox"/>	3	E1	ALAW	DF	HDB3	Short Haul

Total: 56 Page1 v

Modify

Parameter	Explanation
Port No.	The No. of each E1/T1 port
Work Mode	E1 or T1 If E1 is selected for one port, the work modes of all ports are E1.
PCM Mode	PCMA(A LAW) or PCMU(Mu LAW) If A LAW is selected for one port, the work modes of all ports are A LAW. PCMA usually uses in E1 mode while PCMU uses in T1 mode.
Frame Format	Frame formats of E1 port include DF, CRC-4, CRC4_ITU, and the default value is CRC-4; Frame formats of T1 port include F12, F4, ESF, F72, and the default value is F4.
Line Code	Line codes of E1 include NRZ, CMI, AMI, HDB3, and the default value is HDB3; Line codes of T1 include NRZ, CMI, AMI, B8ZS, and the default value is B8ZS.
Line Built-out	Short Haul (-10DB)
Batch Configure	If Disable is selected, E1/T1 parameter cannot be configured at batch; If Enable selected, E1/T1 parameter can be configured at batch;

4.9.3 Port Number

Port Number				
Port	Binding Number	Binding Pool	Type of Incoming Callee	Type of Outgoing Caller
---	---	---	---	---

Total: 0

Port Number	
Port	<input type="text" value="0"/>
Port Binding Number	<input type="text"/>
Port Binding Pool	<input type="text" value="65535 <None>"/>
Type of Incoming Callee	<input type="text" value="Not Replace"/>
Type of Outgoing Caller	<input type="text" value="Not Replace"/>

Parameter	Explanation
Port	No. of the E1/T1 Port
Port Binding Number	The telephone number bound to E1/T1 Port
Port Binding Pool	The telephone number pool bound to E1/T1 Port. the numbers will be chosen in an Incremental way.
Type of incoming Callee	There are three options, namely Replace/Not replace/Replace when empty, for PSTN->IP callee numbers.
Type of outgoing Caller	There are two options, namely Replace/Not replace, for IP->PSTN caller numbers.

4.9.4 Codec Group

On the Codec Group interface, you can group several voice Codecs together, so when one voice Codec is faulty, another voice Codec in the same group can be used. Except Codec group 0, the parameters of other Codec groups can be modified.

Coder Group

Coder Group ID 0(default setting) ▼

	Coder	Payload Type Value	Packetization Time(ms)	Rate(kbps)	Silence Suppression
1st	G711A ▼	8	20 ▼	64	Disable ▼
2nd	G711U ▼	0	20 ▼	64	Disable ▼
3rd	G729 ▼	18	20 ▼	8	Disable ▼
4th	G723 ▼	4	30 ▼	6.3	Disable ▼
5th	▼		▼		▼
6th	▼		▼		▼

Parameter	Explanation
Codec Group ID	ID of each Codec group for voice ability, from 0 to 7. The Codec group 0 is default setting which cannot be modified.
Codec	MTG5000-64E1 supports three kinds of voice Codec: G711A, G711U, G729, G723, iLBC 13k and iLBC 15k.
Payload Type Value	Each Codec has a unique payload type value (make reference to RFC3551).
Packetization Time (ms)	The minimum packetization time of voice Codec. For example, if packetization time is 20ms, voice will be packetized every 30ms.
Rate (kbps)	Transmission rate of voice
Silence Suppression	If silence suppression is enabled, the bandwidth occupied by voice transmission will be released automatically for the silence party or when talking is paused. Default value is 'Disable'.

➤ **Example: How to configure preferred Codec group**

Step1: Enter the Codec Group interface and select Codec group ID 1 to create new Codec group

Step2: Select preferred voice Codec (G711A and G729) in this example, as below:

Coder Group

Coder Group ID: 1

	Coder	Payload Type Value	Packetization Time(ms)	Rate(kbps)	Silence Suppression
1st	G711A	8	20	64	Disable
2nd	G729	18	20	8	Disable
3rd					
4th					
5th					
6th					

Step3: Enter the PSTN Profile interface, click Modify to modify the default PSTN profile and change the Codec group ID, or click Add to add a new PSTN profile.

PSTN Profile Add

PSTN Profile ID: 1

Description:

Coder Group ID: 1

RFC2833 Payload Type: 101

DTMF Tx Priority 1st: RFC2833

DTMF Tx Priority 2nd: SIP INFO

DTMF Tx Priority 3rd: Inband

Overlap Receiving: Disable

Remove CLI: Not remove

Play Busy Tone to PSTN: No

Step4: Click OK to save the above configuration.

Step5: Enter the PSTN Group interface to establish a PSTN group

PSTN Group Add

Trunk Group ID: 1

Name: 123

Channel Selection: Cyclic Ascending

Control Mode: None

Step6: Enter the PSTN Group Management interface to associate the PSTN profile and PSTN group to an E1/T1 port or multiple E1/T1 ports.

PSTN Group Management Add

Group ID: 1 <123>

Start E1: 0

End E1: 7

PSTN Profile ID: 1 <123>

Step7: Click OK save the above configuration.

4.9.5 Dial Plan

Dial plan is used for the MTG5000-64E1 to identify how many digits that a received number includes. Dial rules can be divided into 5 groups with dial plan IDs. The setting in dial plan 0 is the default setting.

Dial Plan			
Dial Plan ID: 0			
Index	Prefix	Min Length	Max Length
<input type="checkbox"/>	0	.	0 30

Total: 1 Page 1

Add Delete Modify

Click the **Add** button, and you can add a new dial plan in the following interface.

Dial Plan Add

Dial Plan ID: 1
 Index: 1999
 Prefix:
 Min Length:
 Max Length:

Parameter	Explanation
Dial Plan ID	The ID of the dial plan
Index	Each dial plan has a unique index. Greater index value, higher priority for the dial plan.
Prefix	The prefix matching received numbers, through which the MTG5000-64E1 can judge how many digits the received number includes.
Min Length	The minimum number of digits included in a telephone number (generally from 0 to 30). If the length of a received number falls within the range of between the set minimum length and the set maximum length, call connection will continue.
Max Length	The maximum number of digits included in a telephone number (generally from 0 to 30). If the length of a received number reaches the set maximum length, MTG5000-64E1 deems that all digits of the number have been received and will begin to analyze the telephone number, and if there are still digits being sent, MTG5000-64E1 will not receive them.

Note:

- Dial plans can be backed up and restored at the **Maintenance -> Data Backup** interface and the **Maintenance -> Data Restore** interface respectively.

2. 'Min Length' and 'Max Length' does not include the length of prefix.
3. For overlapping dialing, it'd better to set 'Min Length' and 'Max Length' to a same value in order to accelerate connection rate, since the length of the called number has been known.

4.9.6 Dial Timeout

On the Dial Timeout interface, you can set the maximum time for collecting prefix and the maximum time for telephone number to reach 'Min Length' and 'Max Length'.

The setting in Dial Timeout 0 is default setting, which can be modified but cannot be deleted.

Dial Timeout					
Dial Timeout ID	Description	Max Time for Collecting Prefix(s)	Time to Reach Min Length(s)	Time to Reach Max Length(s)	
<input type="checkbox"/>	0	Default	20	10	10

Total: 1 Page 1 ▼

Click the **Add** button to add a new dial timeout rule.

Dial Timeout Add

Dial Timeout ID: ▼

Description:

Max Time for Collecting Prefix: s

Time to Reach Min Length(after Prefix): s

Time to Reach Max Length(after Min Length): s

Parameter	Explanation
Dial Timeout ID	The ID of the dial timeout
Description	Description of the dial timeout
Max Time for Collecting Prefix	The maximum time for receiving all the digits of a prefix
Time to Reach Min Length (after Prefix)	After receiving the prefix, the maximum time before receiving the set minimum number of digits included in a telephone number.
Time to Reach Max Length (after Min Length)	After receiving the set minimum number of digits, the maximum time before receiving the set maximum number of digits included in a telephone number.

4.9.7 Srtp Param

The SRTP Secure Real-time Transport Protocol, provides encryption, message authentication, integrity and replay protection for the real-time transport protocol data in unicast and multicast applications. It is used for encrypted transmission of media streams.

Parameter	Explanation
ID	The number to identify SRTP rules
Encryption Mode	Options: disable/adaptive/mandatory
Encryption Methods	The following encryption methods can be enabled and disabled individually: AES_CM_128_HMAC_SHA1_80/AES_CM_128_HMAC_SHA1_32/AES_CM_192_HMAC_SHA1_80/AES_CM_192_HMAC_SHA1_32/AES_CM_256_HMAC_SHA1_80/AES_CM_256_HMAC_SHA1_32

4.9.8 PSTN Cause Mapping

On the **PSTN Cause Mapping** interface, you can configure PSTN Cause Mapping and related parameters, such as PSTN Cause and SIP Error Code.

	PSTN Cause	SIP Error Code
1	<input type="text"/>	<input type="text"/>
2	<input type="text"/>	<input type="text"/>
3	<input type="text"/>	<input type="text"/>
4	<input type="text"/>	<input type="text"/>
5	<input type="text"/>	<input type="text"/>

Parameter	Explanation
PSTN Cause	Call failure reason value on the PSTN side, the range is 1-127.
SIP Error Code	Call failure error code on the IP side, the range is 400-699.

4.9.9 PSTN Profile

On the **PSTN Profile** interface, you can configure PSTN call number rules and related parameters, such as associating a Codec group, a dial plan and a dial timeout to a PSTN profile.

PSTN Profile												
PSTN Profile ID	Description	Coder Group ID	RFC2833 Payload	DTMF Tx PR 1	DTMF Tx PR 2	DTMF Tx PR 3	Overlap Receiving	Dial Plan ID	Dial Timeout ID	Remove CLI	Play Busy Tone to PSTN	
<input type="checkbox"/>	0	Default	1	101	RFC2...	SIP IN...	Inband	Disable	0	0 <Default>	Not remove	No

Total: 1 Page 1 ▾

Click the **Add** button to add a new PSTN profile.

PSTN Profile Add	
PSTN Profile ID	<input type="text" value="1"/>
Description	<input type="text"/>
PBX	<input type="text" value="Disable"/>
Coder Group ID	<input type="text" value="0"/>
RFC2833 Payload Type	<input type="text" value="101"/>
DTMF Tx Priority 1st	<input type="text" value="RFC2833"/>
DTMF Tx Priority 2nd	<input type="text" value="SIP INFO"/>
DTMF Tx Priority 3rd	<input type="text" value="Inband"/>
Nego Priority	<input type="text" value="Remote"/>
Overlap Receiving	<input type="text" value="Disable"/>
Remove CLI	<input type="text" value="Not remove"/>
Play Busy Tone to PSTN	<input type="text" value="No"/>
Srtp Param ID	<input type="text" value="0"/>

Parameter	Explanation
PSTN Profile ID	The ID of the PSTN profile
Description	The description of the PSTN profile
PBX	The device is loaded with PBX firmware, SIP trunk is configured (No. 99, interface internal, port 50600). IP-side inbound calls will be prompted by IVR after PBX is enabled
Codec Group ID	The ID of the Codec group (the Codec group needs to be created at the Codec Group interface first.)
RFC2833 Payload	Default value is 101.
DTMF Tx Priority 1st	There are three ways to send DTMF: RFC2833, SIP INFOR and Inband. You can set their priority. Priority 1 st represents the top priority.
DTMF Tx Priority 2nd	There are three ways to send DTMF: RFC2833, SIP INFOR and Inband. You can set their priority. Priority 2 st represents the second priority.
DTMF Tx Priority 3rd	There are three ways to send DTMF: RFC2833, SIP INFOR and Inband. You can set their priority. Priority 2 st represents the third priority.
Nego Priority	As the called party (IP-PSTN), for RFC2833 payload type identification, DTMF and codec negotiation, the remote side's configuration is the caller's configuration, the local side is TG's configuration.
Overlap Receiving	Default value is 'Disable'; If overlap receiving is enabled, the set 'Dial Plan' and 'Dial Timeout' will work.
Remove CLI	CLI: Calling Line Identification Whether to remove CLI
Play busy tone to PSTN	If 'Yes' is selected, when the called phone is offhook, MTG5000-64E1 will play busy tone to the PSTN side.
Srtp Param ID	Configure the SRTP rule to be used, which uses 0 by default.

4.9.10 PSTN Group

On the **PSTN Group** interface, you can create a PSTN group and set a strategy for channel selection of the group.

PSTN Group				
	Group ID	Name	Channel Selection	Control Mode
<input type="checkbox"/>	0	pstn0	Cyclic Ascending	None

Total: 1 Page 1 ▼

Click the **Add** button to add a new PSTN group.

PSTN Group Add	
Trunk Group ID	<input type="text" value="1"/> ▼
Name	<input type="text"/>
Channel Selection	<input type="text" value="Cyclic Ascending"/> ▼
Control Mode	<input type="text" value="None"/> ▼

Parameter	Explanation
Trunk Group ID	The ID of the trunk group
Name	The name of the trunk group
Channel Selection	<p>There are four selection strategies: Ascending, Descending, Cyclic Ascending and Cyclic Descending.</p> <p>Ascending: to search idle channels starting from channel 0 to channel 31;</p> <p>Cyclic ascending: to search idle channel in an ascending order, starting from the previous idle channel that has been selected</p>
Control Mode	<p>Control mode is also a method for channel selection and works together with the set selection strategy.</p> <p>Options include Master Odd, Master Even and None.</p> <p>Master Odd: it means channels with odd ID will be searched first, and channels with even ID will not be searched until all channels with odd ID have been searched.</p>

4.9.11 PSTN Group Management

On the **PSTN Group Management** interface, you can add start E1/T1 port, end E1 /T1 port, start channel, end channel and PSTN profile to a PSTN group.

Click the **Add** button, and you will see the following configuration interface.

In the above figure, as start E1 is the same with end E1, only one E1 port is used in the PSTN group and you need to set start channel and end channel.

When there is a need to set several E1 ports, it defaults that all the 32 channels of each E1 port are used by the PSTN group.

Parameter	Explanation
Group ID	The ID of the PSTN group
Config Mode	Configure E1 in normal mode and add PSTN Group in a special mode.
Start E1/T1	The start E1/T1 port in this PSTN group
End E1/T1	The end E1/T1 port in this PSTN group
Start Channel	The start channel in this PSTN group
End Channel	The end channel in this PSTN group
PSTN Profile ID	The ID of the PSTN profile in this PSTN group (the PSTN profile needs to be created at the PSTN Profile interface first).

Note:

When the start E1/T1 port is different from the end E1/T1 port, the start channel is channel 0 by default and the end channel is channel 31 by default (it means there is no need to choose a start channel and a end channel).

4.10 SIP Config

This menu manages the configuration parameters related to SIP Trunk. The submenus include SIP Parameters, SIP Trunk, SIP Account, Domain Name Resolution and Redundant Group Settings. The main purpose of configuring these parameters is to support the configuration of SIP trunks. Users need to check the relevant parameters configuration when configuring SIP trunk, matching the port, IP address, and various related SIP header field settings used by the peer.

4.10.1 SIP Parameter

SIP Parameter	
Local SIP UDP Port	5060
Local SIP TCP Port	5060
Local SIP TLS Port	5061
Local Domain	
PRACK Method	Enable ▾
200 OK with SDP	Enable ▾
Remote Party ID	Disable ▾
Session Timers	Disable ▾
Policy of overload Protection	Reject & Rely ErrCode ▾
Error Code(Exceed Max Caps Limit)	486
Error Code(Lack of Resources)	486
Max Caps	100
Pre-Ringback	Disable ▾
Same Number Forbiden	Disable ▾
Diversion	Disable ▾
To	Disable ▾
PPI	Disable ▾
PAI	Disable ▾
HI	Disable ▾
Account Select Mode	Cyclic Ascending ▾
Register Speed	15
Expire Coefficient	0.8 ▾
Refresh Register with Auth	Disable ▾
Precondition	Disable ▾
PSTN->IP Match Diversion Number	Disable ▾
OrgCallee from	PoolNumber ▾
URI including "user=phone"	Disable ▾
AMR Octet Align	Disable ▾
PPbx Info	Disable ▾
181 Forwarding	Disable ▾
Invite with PEM Header	Disable ▾
GE1 Static Nat	Disable ▾
GE0 Static Nat	Disable ▾
User to User Header	Disable ▾
User Agent Header	Disable ▾
SIP Info Dtmf Mode	dtmf-relay ▾
SIP Default Error Code	500
SIP Header Param Escape	Disable ▾

Save

Parameter	Explanation
Local SIP UDP Port	SIP UDP port that the device listens on, 5060 (default)
Local SIP TCP Port	SIP TCP port that the device listens on, 5060 (default)
Local SIP TLS Port	SIP TLS port that the device listens on
Local Domain	A local domain whose format is www.xxx.com
PRACK Method	PRACK: Provisional Response ACK message PRACK is a mechanism to ensure reliable transmission of temporary messages (101-199) in SIP messages. PRACK is generally a confirmation of receipt of <i>183 call in progress/180 ringing</i> .
200 OK with SDP	The 200 OK message sent by the device whether with SDP.
Remote Party ID	When enabled, the <i>invite</i> message sent by the device will come with the <i>Remote Party ID</i> header field to support caller ID.
Session Timers	The user agent periodically sends <i>re-INVITE</i> or <i>UPDATE</i> requests to keep the session active.
Policy of overload Protection	The processing policy when the session request received by the device exceeds the processing capacity of the device, and the error code will be returned to reject/discard directly.
Max Caps	Used with overload protection policy to limit the CAPS of equipment.
Pre-Ringback	When enabled, the device will reply with an <i>18x</i> immediately after receiving the <i>invite</i> .
Same Number Forbidden	When receiving an <i>invite</i> with the same calling and called number, the device will reply with 403 to reject.
Diversion	When enabled, an <i>invite</i> with a <i>Diversion</i> header field (carrying call forwarding information) will be received, and the <i>invite</i> forwarded by the device will with a <i>Diversion</i> header field.
To	When enabled, it will receive an <i>invite</i> message that does not match the called number in the <i>to</i> header with the request line, and the device will extract the called number from the <i>to</i> header.
PPI	When enabled, an <i>invite</i> with a <i>Diversion</i> header or <i>History-Info</i> header (carrying call forwarding information) will be received. The <i>invite</i> forwarded by the device with the <i>P-Preferred-Identity</i> header, and the number in the <i>PPI</i> header is the number in the <i>Diversion</i> header or the <i>History-Info</i> header.
PAI	After enabling, when SIP calls in, if the number in the received <i>PAI</i> header is inconsistent with the caller number, the number in the <i>PAI</i> header will replace the caller number; when SIP calls out, the caller number is encoded in the <i>PAI</i> header

	and send an <i>invite</i> with <i>PAI</i> header.
HI	After enabling, when receiving a call with call forwarding information, the device will send a <i>History-Info</i> header in the <i>invite</i> message.
Account Select Mode	Cyclic Ascending/According to the user name, cyclic ascending is the registration call in <i>access</i> mode. The contact number in the <i>invite</i> forwarded by the device is the SIP account polling on the TG; according to the user name that is the registration call in <i>access</i> mode, the call succeeds when the calling number exists in the SIP account , otherwise the call fails.
Register Speed	The number of registration messages sent per second.
Expire Coefficient	After the SIP account is successfully registered, the device will initiate re-registration within the registration period.
Refresh Register with Auth	When enabled, the refresh registration message forwarded by the device carries authentication information.
Precondition	When enabled, the device will support resource reservation.
PSTN->IP Match Diversion Number	When enabled, if the PSTN-IP routing is configured with a calling number prefix, the received <i>invite</i> will have a <i>division</i> header. When the calling number in the from header does not match the route, the number in the <i>division</i> header will be matched, if the prefix matches, the call is successful.
OrgCallee from	The diversion/number pool number, and <i>divison</i> needs to be enabled; when receiving an <i>invite</i> with a <i>division</i> header, the number configuration in the <i>division</i> header in the <i>invite</i> message forwarded by the device will be the same.
URI including "user=phone"	When enabled, the <i>invite</i> <i>URI</i> , <i>from</i> and <i>to</i> headers sent by the device will come with " <i>user=phone</i> "
AMR Octet Align	When enabled, the device will be act as the called party. If the caller sends out alignment, the negotiation will be aligned; if the caller sends out misaligned, the negotiation will be misaligned.
PPbx Info	When enabled, the calling number type in the IAM (SS7) or SETUP (PRI) message will be the same as the <i>pbx info</i> header in the received <i>sip</i> message.
181 Forwarding	If the received sip message contains the P-Early-Media header field, the local ringback tone or passthrough will be played according to the configuration of the header field. If without this header field, the device will transmit the media stream by default.
Invite with PEM Header	When enabled, the invite message sent by the device will with <i>P-Early-Media: supported</i>

GE1 Static Nat	It is used to register to the public network server on the private network or the calls on public network. When enabling it, you need to configure Nat IP.
GE0 Static Nat	It is used to register to the public network server on the private network or the calls on public network. When enabling it, you need to configure Nat IP.
User to User Header	You need to configure the prefix when you enable it. When the called number of the received <i>invite</i> matches the configured prefix, the <i>invite</i> message sent by the device will with the <i>User-to-User</i> header.
User Agent Header	Configure the value when enabled, the invite sent by the device will with the user-agent header.
SIP Info Dtmf Mode	Compatible with SIP info messages for dtmf-delay and ssc mode
SIP Default Error Code	In some cases, the device sends this error code to disconnect the call.
SIP Header Param Escape	When receiving an invite and then replying with 18x, 200ok, the parameters in the SIP header are escaped to special characters by default. When enabled, the parameters are not escaped as special characters.

4.10.2 SIP Trunk

SIP trunk can realize the connection between MTG5000-64E1 and PBX or SIP servers under the IP network. It provides two modes to connect MTG5000-64E1 and the IP network. One is Access (MTG5000-64E1 registers to a softswitch), and the other is Peer (MTG5000-64E1 connects to a peer device in the IP network via IP address).

SIP Trunk												
Trunk No.	Trunk Name	Remote Address	Remote Port	Support SIP-T	Get Callee from	Get Caller from	Register to Remote	Outgoing Call Mode	Incoming Authentication Type	Detect Trunk Status	Enable SIP Trunk	
<input type="checkbox"/>	0	AG	172.16.22.22	5060(UDP)	Disable	Request...	User Na...	No	Peer	IP Address	No	Yes
<input type="checkbox"/>	1	sipp	172.16.118.143	5067(UDP)	Disable	Request...	User Na...	No	Peer	IP Address	No	Yes

Total: 2 Page 1

Configuration procedures for Peer Mode are as follows:

- 1) Click the **Add** button to add a SIP trunk.
- 2) Configure parameters on the SIP Trunk Add interface according to related explanations in the table.
As it is Peer mode, you should select No for the Register to Remote parameter, and enter the IP address of the peer device.
- 3) After finishing the configuration of the parameters, click **OK**.

SIP Trunk Add

Trunk No.	0
BI	GE1
Trunk Name	
Remote Address	
Protocol Type	UDP
Remote Port(UDP)	5060
Remote Port(TCP/TLS)	5060
Outbound Proxy	
Outbound Proxy Protocol Type	UDP
Outbound Proxy Port(UDP)	5060
Outbound Proxy Port(TCP/TLS)	5060
From Header	Local Domain
PPID	Disable
Local Domain	Disable
Support SIP-T	Disable
Get Callee from	Request-line
Get Caller from	User Name
Register to Remote	No
Incoming SIP Authentication Type	IP Address
Rport	Disable
Dynamic Nat	Disable
Static Nat	Disable
Outgoing Calls Restriction	No
Incoming Calls Restriction	No
Incoming Time Restriction	Disable
Heartbeat Bound	Disable
Detect Trunk Status	No
Heartbeat Username	heartbeat
Enable SIP Trunk	Yes
Early Alerting	Disable
No Prack for Incoming Call	Disable
User to User(callee caller)	Disable
Request Add Port	Disable
OPTION Only Detects 200OK	Disable
Heartbeat Bound PSTN Group	Disable

OK
Reset
Cancel

NOTE: The "Remote Address", "Remote Port"(UDP,TCL/TLS) cannot be the same in different SIP trunks.

Parameter	Explanation
Trunk No.	The No. of the SIP trunk (range is 1 ~99)
BI	Which network port the call is sent from, users can select GE0/GE1.
Trunk Name	The name of the SIP trunk
Remote Address	The IP address of the peer device interfacing with the MTG5000-64E1

Protocol Type	Options include UDP, TCP and Auto If Auto is selected, the protocol type is determined by the peer device.
Remote Port (UDP)	The SIP port of the peer device interfacing with the MTG5000-64E1; The default remote port is 5060.
Remote Port (TCP/TLS)	Configure the peer port for TCP/TLS protocol.
Outbound Proxy	SIP proxy IP address If outbound proxy is used, enter the IP address or domain name of the proxy server
Outbound Proxy Protocol Type	Options include UDP, TCP and Auto If Auto is selected, the protocol type is determined by the peer device.
Outbound Proxy Port (UDP)	The default outbound proxy port is 5060.
Outbound Proxy Port(TCP/TLS)	Configure proxy port for TCP/TLS protocol.
From Header	You can select the local domain name/peer domain name. The <i>from header</i> in the invite message sent by the device can be the local domain name in the SIP parameters or the SIP trunk's peer address (configured as a domain name).
PPID	When enabled, the P-Preferred-Identity header and Privacy header are added to the invite packets sent by the device.
Local Domain	The local domain set in the SIP Parameter interface
Support SIP-T	This parameter is for SS7. Its default value is 'Disable'.
Get Callee from	Get the called number from 'Request-line' or 'To Header Field'
Get Caller from	Get the caller number from 'User Name' or 'Display Name'
Register to Remote	It is defined by IETF RFC3372, which is a standard used to establish remote communication between SIP and ISUP; The default value is 'Yes'. If 'Yes' is selected, MTG5000-64E1 will be registered to the peer device whose IP address is filled in 'Remote Address'.
Incoming SIP Authentication Type	Incoming calls from IP network can be authenticated by IP address or password. If password is selected, you need fill in password. If IP address is selected, incoming calls will be rejected when their IP address are different from the remote address filled in.

Rport	Whether to enable the Rport of the SIP trunk
Dynamic Nat	Enable or Disable If it is enabled, a private IP address can be mapped to a public address from a pool of public IP addresses.
Static Nat	Static NAT enables one-to-one mapping of local and public addresses. A public IP address is assigned only to a unique and fixed local network host.
Outgoing Calls Registration	Whether to limit the number of the calls from PSTN to IP network. The default value is 'No'. If 'Yes' is selected, then input the number of concurrent calls that are allowed to go out. The range is 0 to 65535.
Incoming Calls Registration	Whether to limit the number of the calls from IP network to PSTN. The default value is 'No'. If 'Yes' is selected, then input the number of concurrent calls that are allowed to come in. The range is 0 to 65535.
Incoming Time Registration	The default setting is 'Disabled'. If 'Enabled' is selected, user can edit the start and stop time of a prohibition period. During this period, all calls from IP network to PSTN are prohibited. (Calls from PSTN to IP network are not limited)
Heartbeat Bound	Heartbeat bound is used in transcoding mode, and users need to configure the bounding sip trunk number when enabled. When the heartbeat of bounding sip trunk A is good, the device replies to the heartbeat message sent by the peer device of the SIP trunk B.
Detect Trunk Status	Whether to detect the status of the SIP trunk. If 'Yes' is selected, MTG5000-64E1 will send Heartbeat message to the peer device to confirm whether the link status is OK.
Heartbeat Username	The name of the Heartbeat message
Enable SIP Trunk	Whether to enable the SIP trunk. If 'Yes' is selected, the SIP trunk is available; If 'No' is selected, the SIP Trunk is invalid.
Early Alerting	Early Alerting is used in transcoding mode, TG replies 18x immediately after receiving invite when enabled.
No Prack for Incoming Call	When disabled, the device carries require when it sends 18x.
User to User(callee caller)	When enabled, the forwarded invite message carries the User to User header with the value "callee caller".

Request Add Port	When enabled, the request line in the sent SIP message carries the SIP trunk configuration's peer port.
OPTION Only Detects 200OK	When enabled, the link between the device and SIP trunk is determined to be normal only when the device sends an option message and the peer replies with 200 ok. When disabled, the link can be judged as normal for a reply to the option message sent by the device.
Heartbeat Bound PSTN Group	When enabled, the device replies to the heartbeat option message on the remote side only when one or all E1 ports of the bound PSTN group are green.

Configuration procedures For Access M Configuration procedures for Access mode are as follows:

- 1) Click the **Add** button to add a SIP trunk.
- 2) Configure parameters on the following interface according to related explanations. As it is Access mode, you should select **Yes** for the **Register to Remote** parameter, and enter the IP address of a softswitch.

SIP Trunk Add

Trunk No.	0
BI	GE1
Trunk Name	
Remote Address	
Protocol Type	UDP
Remote Port(UDP)	5060
Remote Port(TCP/TLS)	5060
Outbound Proxy	
Outbound Proxy Protocol Type	UDP
Outbound Proxy Port(UDP)	5060
Outbound Proxy Port(TCP/TLS)	5060
From Header	Local Domain
PPID	Disable
Local Domain	Disable
Support SIP-T	Disable
Get Callee from	Request-line
Get Caller from	User Name
Register to Remote	No
Incoming SIP Authentication Type	IP Address
Rport	Disable
Dynamic Nat	Disable
Static Nat	Disable
Outgoing Calls Restriction	No
Incoming Calls Restriction	No
Incoming Time Restriction	Disable
Heartbeat Bound	Disable
Detect Trunk Status	No
Heartbeat Username	heartbeat
Enable SIP Trunk	Yes
Early Alerting	Disable
No Prack for Incoming Call	Disable
User to User(callee caller)	Disable
Request Add Port	Disable
OPTION Only Detects 200OK	Disable
Heartbeat Bound PSTN Group	Disable

OK
Reset
Cancel

NOTE: The "Remote Address", "Remote Port"(UDP,TCL/TLS) cannot be the same in different SIP trunks.

- 3) Click **OK**.
- 4) Click **SIP Account** in the navigation tree on the left, and then click **Add** to add a SIP account.

SIP Account

	SIP Account ID	Description	Binding PSTN Group	SIP Trunk No.	Username	Expire Time
<input type="checkbox"/>	0	09902	None	0 <softswitch>	09902	1800

Total: 1 Page 1

Add
Delete
Modify

- 5) Configure the parameters on the **SIP Account Add** interface.

The screenshot shows the 'SIP Account Add' configuration window. It contains the following fields and values:

- SIP Account ID: 1
- Description: 09902
- Binding PSTN Group: None
- SIP Trunk No.: 0 <softswitch>
- Username: 09902
- Authenticate ID: 09902
- Password: ****
- Confirm Password: ****
- Expire Time: 1800s

At the bottom of the window are three buttons: OK, Reset, and Cancel.

Parameter	Explanation
SIP Account ID	The ID of SIP Account, from 0 to 127
Description	Description of the SIP account
Binding PSTN Group	Choose a PSTN group that is bound to the SIP account
SIP Trunk No.	The No. of the SIP trunk bound to the SIP account
Username	The username of the SIP account, which is used to register the SIP account to softswitch
Authenticate ID	The authentication ID to authenticate the SIP account for the softswitch connected to MTG5000-64E1
Password	The password of SIP account, which is used when the SIP account is registered to softswitch
Confirm Password	Enter the password again
Expire Time	The interval to register the SIP account; Default value is 1800s.

- 6) Click **OK**. And you can click **Status & Statistics -> IP Trunk Status** to check the SIP trunk that has been established.

4.10.3 SIP Account

Filter Condition

SIP Trunk No. Username

SIP Account

ID	Description	Binding PSTN Group	SIP Trunk No.	Username	Expire Time	Max Calls	Enable Account
---	---	---	---	---	---	---	---

Total: 0

SIP Account Add

SIP Account ID

Description

Binding PSTN Group

SIP Trunk No.

Username

Authenticate ID

Password

Confirm Password

Expire Time s

Max Calls

Enable Account

SIP Account Batch Add

Start SIP Account ID

SIP Trunk No.

Username Prefix

Start Username

Authenticate ID Username@

Auth ID Add Prefix

Account Count max:2000

Password Policy

Password

Expire Time s

Max Calls

Enable Account

NOTE: The maximum of sip account is 2000.

Description about add of SIP accounts:

Parameter	Explanation
SIP Account ID	SIP account ID, between 0-999
Description	Describe the SIP account
Binding PSTN Group	Access mode, configured PSTN group call, the number in the contact header of the invite message sent by the device is the SIP account bound to the PSTN, not the original calling number, nor the SIP account polling, only in <i>pstn</i> -> <i>ip</i> routing direction.
SIP Trunk No.	Corresponding to the SIP trunk number
Username	SIP registered user name
Authentication ID	The authentication ID of the SIP account configured by the SIP server, which can be empty.
Password	Password for registering SIP account
Confirm Password	Enter confirm password
Expire Time	SIP registration interval
Max Calls	The device will reject calls that exceed the number of concurrent.
Enable Account	The enabled SIP account can be registered and called normally

Description about batch add of SIP accounts:

Parameter	Explanation
Start SIP Account ID	The first SIP account number, subsequent SIP accounts are incremented.
SIP Trunk No.	SIP trunk number
Username Prefix	The common prefix of the SIP accounts added in batches, which can be empty.
Start Username	The first SIP account registered user name, subsequent SIP accounts are incremented.
Authenticate ID	The authentication ID of the SIP account configured by the SIP server, which can be empty.
Auth ID Add Prefix	Whether to add the user name prefix before the authentication ID.
Account Count	The number of SIP accounts that can be added in batches.
Password Policy	Choose a password policy (Life Password/ The same with username)
Password	Configure when the password policy is a universal password
Expire Time	SIP registration interval
Max Calls	The device will reject calls that exceed the number of concurrent.

Enable Account	The enabled SIP account can be registered and called normally
----------------	---

4.10.4 SIP DNS

Shows the correspondence between SIP domain names and IP.

SIP DNS			
Trunk No	Domain Name	IP	Priority
---	---	---	---

4.10.5 SIP RED Group

Put two trunks into the same redundancy group, one is the master and the other is the slave. The master needs to enable Keep Alive, and the slave does not need it. The device will send calls to the master trunk first. When the Keep Alive detects that the master trunk is down, it will switch to the slave trunk to forward the call. At the same time, it will always check the master trunk status. Once the master trunk status is OK, it will immediately switch back to the master trunk.

SIP Redundancy Group		
Group Id	Index	Trunk No.
---	---	---

Total: 0 ▾

Add Sip Redundancy Group Member	
Group Id	0 ▾
Index	0 ▾
Trunk No.	▾

Note: The 'Index 0' trunk must turn on heartbeat detection

Parameter	Explanation
Group ID	Number of redundancy group, 8 redundancy groups can be added.
Index	0 is the master trunk, and 1 is the slave trunk.
Trunk No.	For SIP trunks with redundant grouping enabled, the trunk corresponding to 'index 0' must enable Keep Alive.

4.11 IP Group Config

This menu manages some service control parameters in IP calls, including IP rules, IP groups and IP group management. Users can manage the service settings for IP calls through IP rules and IP groups, such as early media stream support, ringback tone source settings, call Concurrent settings in IP groups, etc. Users can use IP rules to achieve compatibility support in some call services.

4.11.1 IP Profile

On the IP Profile interface, you can configure the parameters about IP calls, such as whether to support early media, where ringback tone to PSTN/IP is originated from and whether to wait for RTP packet from peer device.

IP Profile								
IP Profile ID	Description	Declare RFC2833 in SDP	Support Early Media	Ringback Tone to PSTN Originated from	Ringback Tone to IP Originated from	Wait for RTP Packet from Peer	T.30 Expanded Type in SDP	
<input type="checkbox"/>	0	Default	Yes	Yes	IP	PSTN	No	X-Fax

Total: 1 Page 1 ▾

Click Add, and the following interface will be displayed.

IP Profile Add

IP Profile ID	<input type="text" value="1"/>
Description	<input type="text" value="123456"/>
Declare RFC2833 in SDP	<input type="text" value="No"/>
Support Early Media	<input type="text" value="Yes"/>
Ringback Tone to PSTN Originated from	<input type="text" value="Local"/>
Ringback Tone to IP Originated from	<input type="text" value="Local"/>
Wait for RTP Packet from Peer	<input type="text" value="No"/>
T.30 Expanded Type in SDP	<input type="text" value="X-Fax"/>

Parameter	Explanation
IP Profile ID	The ID of the IP profile, from 1 to 15.
Description	Description of the IP profile
Declare RFC2833 in SDP	Whether to declare RFC2833 in SDP Default value is 'Yes'.
Support Early Media	Whether to support Early Media (183) If 'Yes' is selected, ringback tone will be played to the caller before the call is successfully connected.
Ringback Tone to PSTN Originated from	Where the ringback tone to PSTN side is originated from If 'Local' is selected, the ringback tone is played from MTG5000-64E1. If 'IP' is selected, the ringback tone is played from the IP network
Ringback Tone to IP Originated from	Where the ringback tone to IP network is originated from If 'Local' is selected, the ringback tone is played from MTG5000-64E1. If 'PSTN' is selected, the ringback tone is played from the PSTN.
Wait for RTP Packet from Peer	If 'Yes' is selected, RTP packets will be sent from peer device to MTG5000-64E1 first, and then RTP packets will be sent from TG to peer device. If 'No' is selected, RTP packets will be sent automatically during calling;
T.30 Expanded Type in SDP	There are two T.30 expanded types: X-Fax and Fax

4.11.2 IP Group

On the IP Group interface, you can add IP groups and choose a strategy for selecting IP trunks.

Group ID	Name	IP Trunk Selection
---	---	---

Total: 0

Buttons: Add, Delete, Modify

Click **Add**, and the following interface will be displayed.

IP Group Add

IP Group ID: 0

Name:

IP Trunk Selection: Cyclic Ascending

Max Out: 65535

Max In: 65535

Buttons: OK, Reset, Cancel

Belong to	Parameter	Explanation
IP Trunk Selection	Ascending	To select IP trunks in an ascending order under a same group.
	Cyclic Ascending	To select IP trunks in an ascending order, starting from the previous IP trunk that has been selected
	Descending	To select IP trunks in a descending order under a same group
	Cyclic Descending	To select IP trunks in a descending order, starting from the previous IP trunk that has been selected
Max Out	Max Out	The maximum number of concurrent outgoing calls of IP group
Max In	Max In	The maximum number of concurrent incoming calls of IP group

4.11.3 IP Group Management

On the **IP Group Management** interface, you can add IP trunks to the IP group which have been established on IP Group interface.

IP Trunk Group					
	Group ID	Index	Trunk Type	Trunk No.	IP Profile ID
<input type="checkbox"/>	0 <123456>	0	SIP	0 <softswitch>	0 <Default>
<input type="checkbox"/>	0 <123456>	1	SIP	2 <AG_peng>	0 <Default>

Total: 2 Page 1 ▾

Click **Add**, and you can see the following interface.

IP Trunk Group Add	
IP Group ID	0 <123456> ▾
Index	2 ▾
Trunk Type	SIP ▾
Trunk No.	0 <softswitch> ▾
IP Profile ID	0 <Default> ▾

Parameter	Explanation
IP Group ID	The ID of the IP group If you want to add more IP trunks to the IP group, do not change the IP group ID.
Index	The index of the IP trunk added to the IP group
Trunk Type	SIP
Trunk No.	Select an IP trunk that has been established on SIP Config -> SIP Trunk interface.
IP Profile ID	The ID of the IP profile that will be used by the IP trunk.

4.12 Number Filter

This menu manages the black and white list of calling and callee numbers. The main purpose of configuring this menu is to have flexible black and white list filtering support for calling and callee numbers. The submenu settings include caller and callee black/white lists, caller number pool, Number Bound TsNo and filter profile. These configurations are bound to each other and achieved by filtered profile. when setting them, users need to avoid filtering out important calling numbers. Advanced users need to understand the actual customer needs before configuring this parameter and use its filtering function through certain tests.

Caller White List: Calls from the numbers on the Caller White List will be allowed to pass. If a caller number cannot match with one of the numbers on the Caller White List, calls from the caller number will be rejected.

Caller Black List: Calls from the numbers on the Caller Black List will be rejected to pass. If a caller number match with one of the numbers on the Caller Black List, calls will be rejected.

Callee White List: Calls to the numbers on the Callee White List will be allowed to pass. If a callee number cannot match with one of one of the numbers on the Caller White List, calls to the callee number will be rejected.

Callee Black List: Calls to the numbers on the Callee Black List will be rejected to pass. If a callee number match with one of the numbers on the Callee Black List, calls to the callee number will be rejected.

4.12.1 Procedures to add a number on the Caller White List

- 1) Click **Number Filter** -> **Caller White List** to enter into the following interface.

- 2) Click **Add** to enter into the following interface to add a caller number on the Caller White List.

- 3) Choose an ID for the caller white list and an index for the caller number, and then enter the caller number.
- 4) Click OK.

Note:

You can add 8 white or black lists at most, with ID from 0 to 7. And each white or black list can contain 1024 numbers at most.

4.12.2 Caller Pool

On the Caller Pool interface, you can add a batch of telephone numbers to replace the actual caller numbers when there is a need.

Click **Add** to set numbers in the caller pool.

Note:

If 'Starting Caller Number' is 80080000 and 'Number Count' is 100, it means numbers from 80080000 to 80080099 are all in the caller pool. Each caller pool can contain 512 numbers at most, and if there are multiple caller pools, the caller pools can contain up to 1024 numbers in total.

4.12.3 Number Bound TsNo

Add Time Slot Bound Number

Number Bound Ts Group ID	0 ▼
Index	0 ▼
Call Number	
E1 Port	0 ▼
TsNo	1 ▼

Each TsNo is bound to a number. If the called number is the bound TsNo, it means the call is normal. When the called number is not the bound TsNo, the MTG5000-64E1 device will reply “503” to refuse the call.

4.12.4 Filter Profile

On the Filter Profile interface, you can put white lists and black lists that have been set before in a filter profile or several profiles. The white lists and black lists will not take effect until you set them in filter profiles.

Filter Profile

Filter Profile ID	Description	Caller White List ID	Caller Black List ID	Callee White List ID	Callee Black List ID	Caller Pool for White List	Caller Pool for Black List	Caller Pool for Transfer	Rcd Caller White List	Rcd Callee White List	Recog Caller White List	Recog Callee White List	Callee Bound Tsno	Presentation Indicator
---	---	---	---	---	---	---	---	---	---	---	---	---	---	---

Total: 0 ▼

Filter Profile Add

Filter Profile ID	0 ▼
Description	
Caller White List ID	255 <None> ▼
Caller Black List ID	255 <None> ▼
Callee White List ID	255 <None> ▼
Callee Black List ID	255 <None> ▼
Caller Pool for White List	255 <None> ▼
Caller Pool for Black List	255 <None> ▼
Caller Pool for Calling Transfer	255 <None> ▼
Rcd Caller White List	255 <None> ▼
Rcd Callee White List	255 <None> ▼
Recog Caller White List	255 <None> ▼
Recog Callee White List	255 <None> ▼
Callee Bound TsNo	255 <None> ▼
Presentation Indicator	Not Configured ▼

Select a white list ID, and the calls of the numbers on the white list will be passed. Select a black list ID, and the calls of the numbers on the black list will be prohibited.

If you select **255<None>**, it means no while lists or black lists are set in filter profile, and no numbers will be filtered.

4.13 Call Routing

This menu manages the routing direction of calls. Call routing is mainly responsible for the call routing parameters from IP to PSTN and from PSTN to IP.

Its submenu parameters include basic routing parameters, PSTN->IP call routing, PSTN->PSTN call routing, and IP->PSTN call routing. Other binding rules set in call routing help users to flexibly control the call service in a certain direction. Users need to understand different PSTN ports and corresponding SIP trunk parameters when configuring call routing, otherwise there may be call failure.

4.13.1 Routing Parameter

Routing Parameter

Incoming Calls from IP

Routing Priority First IP->PSTN, then IP->IP ▼

Routing & Manipulation Routing before Manipulation ▼

Incoming Calls from PSTN

Routing Priority First PSTN->IP, then PSTN->PSTN ▼

Routing & Manipulation Routing before Manipulation ▼

Belong To	Parameter	Explanation
Incoming Calls from IP	Routing Priority	There are two options: First IP ->PSTN, then IP ->IP First IP ->IP, then IP ->PSTN
	Routing & Manipulation	There are two options: Routing before Manipulation Routing after Manipulation
Incoming Calls from PSTN	Routing Priority	First PSTN ->IP, then PSTN ->PSTN
	Routing & Manipulation	There are two options: Routing before Manipulation Routing after Manipulation

4.13.2 PSTN -> IP Routing

On the **PSTN -> IP Routing** interface, you can set routing parameters for PSTN -> IP calls.

PSTN->IP Routing

Index	Description	Trunk No.	PSTN Group	Callee Prefix	Caller Prefix	Trunk Type	Trunk No.	Destination IP Group	Filter Profile ID
---	---	---	---	---	---	---	---	---	---

Total: 0 ▼

Click **Add**, and the following interface will be displayed.

Route PSTN->IP Add

Index	255 ▼
Description	
Source Type	Group ▼
PSTN Group	Any ▼
Callee Prefix	
Caller Prefix	
Destination Type	Group ▼
Destination IP Group	▼
Number Filter Profile ID	255 <None> ▼

Parameter	Explanation
Index	The Index of the PSTN -> IP route, from 0 to 255. Greater index value, higher priority for the route.
Description	The description of the PSTN -> IP route,
Source Type	Sources include PSTN group and PRI/SS7/R2 trunk.
PSTN Group	If source is PSTN group, please select a specific PSTN group. If 'Any' is selected, it means the source is any PSTN group.
Callee Prefix	The prefix configured for callee number. When a callee number matches the prefix, this PSTN -> IP route will be used. '.' is a wildcard, which means this PSTN -> IP route will be used, no matter what the callee number is.
Caller Prefix	The prefix configured for caller number. When a caller number matches the prefix, this PSTN -> IP route will be used. '.' is a wildcard, which means this PSTN -> IP route will be used, no matter what the caller number is.
Destination Type	Destination is IP group or SIP trunk.
Destination IP Group	If source is IP group, please select a specific IP group.
IP Trunk No.	If source is SIP trunk, please select a specific IP trunk.
Number Filter Profile ID	The ID of filter profile. The white lists and black lists set in the filter profile will apply to this PSTN -> IP route.

4.13.3 PSTN -> PSTN Routing

On the **PSTN -> PSTN Routing** interface, you can set routing parameters for PSTN -> PSTN calls.

Click **Add**, and the following interface will be displayed.

Parameter	Explanation
Index	The Index of the PSTN -> PSTN route, from 0 to 255. Greater index value, higher priority for the route.
Description	The description of the PSTN -> PSTN route,
Source Type	Sources include PSTN group and PRI/SS7/R2 trunk.
PSTN Group	If source is PSTN group, please select a specific PSTN group. If 'Any' is selected, it means the source is any PSTN group.
Callee Prefix	The prefix configured for callee number. When a callee number matches the prefix, this PSTN -> IP route will be used. '.' is a wildcard, which means this PSTN -> PSTN route will be used, no matter what the callee number is.
Caller Prefix	The prefix configured for caller number. When a caller number matches the prefix, this PSTN -> PSTN route will be used. '.' is a wildcard, which means this PSTN -> PSTN route will be used, no matter what the caller number is.
Destination Type	Destination is PSTN group or PRI/SS7/R2 trunk.
Destination IP Group	If source is PSTN group, please select a specific PSTN group.
Number Filter Profile ID	The ID of filter profile. The white lists and black lists set in the filter profile will apply to this PSTN -> PSTN route.

4.13.4 IP -> PSTN Routing

On the **PSTN -> IP Routing** interface, you can set routing parameters for IP -> PSTN calls.

IP->PSTN Routing									
Index	Description	Trunk Type	Trunk No.	IP Group	Callee Prefix	Caller Prefix	Destination PSTN Trunk	Destination PSTN Group	Filter Profile ID
---	---	---	---	---	---	---	---	---	---
									Total: 0
<input type="button" value="Add"/> <input type="button" value="Delete"/> <input type="button" value="Modify"/>									

Click **Add**, and the following interface will be displayed.

IP->PSTN Routing Add	
Index	255
Description	
Source Type	Group
Trunk Type	Any
IP Group	
Callee Prefix	
Caller Prefix	
Destination Type	Group
Destination PSTN Group	
Filter Profile ID	255 <None>

Parameter	Explanation
Index	The Index of the IP -> PSTN route, from 0 to 255. Greater index value, higher priority for the route.
Description	The description of the IP -> PSTN route,
Source Type	Sources include IP group and IP trunk.
Trunk Type	If source is IP trunk, please select a specific SIP trunk. If 'Any' is selected, it means the source is any IP trunk. .
Callee Prefix	The prefix configured for callee number. When a callee number matches the prefix, this IP -> PSTN route will be used. '.' is a wildcard, which means this IP -> PSTN route will be used, no matter what the callee number is.
Caller Prefix	The prefix configured for caller number. When a caller number matches the prefix, this IP -> PSTN route will be used. '.' is a wildcard, which means this IP -> PSTN route will be used, no matter what the caller number is.
Destination Type	Destination is PSTN group or PRI/SS7/R2 trunk.
Destination IP Group	If source is PSTN group, please select a specific PSTN group.
IP Trunk No.	If source is PRI/SS7/R2 trunk, please select a specific PRI/SS7/R2 trunk.
Number Filter Profile ID	The ID of filter profile. The white lists and black lists set in the filter profile will apply to this PSTN -> PSTN route.

4.14 Number Manipulation

This menu manages the number manipulation. In some scenarios, users need to change the caller or callee number and then proceed with the call flow. The number manipulation on the device can support manipulation in six directions, including PSTN->IP Callee/Caller, PSTN->PSTN Callee/Caller, and IP->PSTN Callee/Caller. According to the call routing direction, the manipulation rules can support number changing such as removing prefix and adding suffix. Advanced users should pay attention to the connection routing rules and manipulation specific requirements when using number manipulation, which can cause call failure or other errors if not set properly.

4.14.1 PSTN -> IP Callee

On the **PSTN -> IP Callee** interface, you can set rules to change the actual callee number during **PSTN -> IP** calling process.

PSTN->IP Callee										
Index	Description	PSTN Trunk	PSTN Group	Callee Prefix	Caller Prefix	Number of Digits to Strip from Left	Number of Digits to Strip from Right	Prefix to Be Added	Suffix to Be Added	Number of Digits to Reserve from Right
---	---	---	---	---	---	---	---	---	---	---

Total: 0

Click **Add**, and the following interface will be displayed.

PSTN->IP Callee Add

Index	<input type="text" value="511"/>
Description	<input type="text"/>
Srouce Type	<input type="text" value="Group"/>
PSTN Group	<input type="text" value="Any"/>
Callee Prefix	<input type="text"/>
Caller Prefix	<input type="text"/>
Number of Digits to Strip from Left	<input type="text"/>
Number of Digits to Strip from Right	<input type="text"/>
Prefix to Be Added	<input type="text"/>
Suffix to Be Added	<input type="text"/>
Number of Digits to Reserve from Right	<input type="text"/>

Parameter	Explanation
Index	The index of this PSTN -> IP callee number manipulation, from 0 to 511. Each index cannot be used repeatedly.
Description	The description of this PSTN -> IP callee number manipulation.
Source Type	Select PSTN group or PSTN Trunk as source type.
PSTN Group	Select a PSTN group. The callee number will be manipulated when a call uses a trunk of this PSTN group, actual callee prefix matches the set callee prefix, and actual caller prefix matches the set caller prefix. 'Any' means any PSTN group.
PSTN Trunk	Select a PRI/R2/SS7 trunk.
Callee Prefix	Set a prefix for the callee number.
Caller Prefix	Set a prefix for the caller number
Number of Digits to Strip from Left	The number of digits which are lessened from the left of the callee number.
Number of Digits to Strip from Right	The number of digits which are lessened from the right of the callee number.
Prefix to be added	The prefix added to the callee number after its digits are lessened.
Suffix to be added	The suffix added to the callee number after its digits are lessened.
Number of Digits to Reserve from Right	The number of the retained digits which. are counted from the right of the callee number.

For example:

- ✧ If the called number is 25026531014, how do you change it into 026531014 ?
- ✧ You can enter '3' in the value box for the 'Number of Digits to Strip from Left' parameter.
- ✧ If the called number is 2653101413, how do you change it into 00912653101413?
- ✧ You can enter '0091' in the value box for the 'Callee Prefix' parameter.

4.14.2 PSTN -> IP Caller

On the **PSTN -> IP Caller** interface, you can set rules to change the actual caller number during PSTN -> IP calling process.

PSTN->IP Caller											
Index	Description	PSTN Trunk	PSTN Group	Callee Prefix	Caller Prefix	Number of Digits to Strip from Left	Number of Digits to Strip from Right	Prefix to Be Added	Suffix to Be Added	Number of Digits to Reserve from Right	Presentation Indicator
---	---	---	---	---	---	---	---	---	---	---	---

Total: 0

Click **Add**, and the following interface will be displayed.

PSTN->IP Caller Add

Index	<input type="text" value="511"/>
Description	<input type="text"/>
Source Type	<input type="text" value="Group"/>
PSTN Group	<input type="text" value="Any"/>
Callee Prefix	<input type="text"/>
Caller Prefix	<input type="text"/>
Number of Digits to Strip from Left	<input type="text"/>
Number of Digits to Strip from Right	<input type="text"/>
Prefix to Be Added	<input type="text"/>
Suffix to Be Added	<input type="text"/>
Number of Digits to Reserve from Right	<input type="text"/>
Presentation Indicator	<input type="text" value="Not Configured"/>
1st Number Type	<input type="text" value="International number"/>
Add Prefix for 1st Number Type	<input type="text"/>
2nd Number Type	<input type="text" value="National number"/>
Add Prefix for 2nd Number Type	<input type="text"/>

Parameter	Explanation
Index	The index of this PSTN -> IP caller number manipulation, from 0 to 511. Each index cannot be used repeatedly.
Description	The description of this PSTN-> IP caller number manipulation.
Source Type	Select PSTN group or PSTN Trunk as source type.
PSTN Group	Select a PSTN group. The caller number will be manipulated when a call uses a trunk of this PSTN group, actual callee prefix matches the set callee prefix, and actual caller prefix matches the set caller prefix. 'Any' means any PSTN group.
PSTN Trunk	Select a PRI/R2/SS7 trunk.
Callee Prefix	Set a prefix for the callee number.
Caller Prefix	Set a prefix for the caller number.
Number of Digits to Strip from Left	The number of digits which are lessened from the left of the caller number.
Number of Digits to Strip from Right	The number of digits which are lessened from the right of the caller number.
Prefix to be added	The prefix added to the caller number after its digits are lessened.
Suffix to be added	The suffix added to the caller number after its digits are lessened.
Number of Digits to Reserve from Right	The number of the retained digits which. are counted from the right of the caller number.
Presentation Indicator	If "Allowed" is selected, the calling number will be presented. If "Restricted" is selected, the calling number will not be presented. If "Not Config" is selected, the parameter does not work.
1 st Number Type	If the caller number belongs to 1 st number type, the set prefix will be added to the caller number.
Add Prefix for 1 st Number Type	The prefix that will be added to those numbers that belong to 1 st number type.
2 nd Number Type	If the caller number belongs to 2 nd number type, the set prefix will be added to the caller number.
Add Prefix for 2 nd Number Type	The prefix that will be added to those numbers that belong to 2 nd number type.

4.14.3 PSTN -> PSTN Callee

On the **PSTN -> PSTN Callee** interface, you can set rules to change the actual callee number during PSTN -> PSTN calling process.

PSTN->PSTN Callee										
Index	Description	PSTN Group	Callee Prefix	Caller Prefix	Number of Digits to Strip from Left	Number of Digits to Strip from Right	Prefix to Be Added	Suffix to Be Added	Number of Digits to Reserve from Right	Number Type
--	--	--	--	--	--	--	--	--	--	--

Total: 0

Click **Add**, and the following interface will be displayed.

PSTN->PSTN Callee Add

Index	511 <input type="button" value="v"/>
Description	<input type="text"/> *
PSTN Group	Any <input type="button" value="v"/>
Callee Prefix	<input type="text"/> *
Caller Prefix	<input type="text"/> *
Number of Digits to Strip from Left	<input type="text"/>
Number of Digits to Strip from Right	<input type="text"/>
Prefix to Be Added	<input type="text"/>
Suffix to Be Added	<input type="text"/>
Number of Digits to Reserve from Right	<input type="text"/>
Number Type	Not Configured <input type="button" value="v"/>

Parameter	Explanation
Index	The index of this PSTN -> PSTN callee number manipulation, from 0 to 511. Each index cannot be used repeatedly.
Description	The description of this PSTN-> PSTN callee number manipulation
PSTN Group	Select a PSTN group. The callee number will be manipulated when a call uses a trunk of this PSTN group, actual callee prefix matches the set callee prefix, and actual caller prefix matches the set caller prefix. 'Any' means any PSTN group.
Callee Prefix	Set a prefix for the callee number.
Caller Prefix	Set a prefix for the caller number.
Number of Digits to Strip from Left	The number of digits which are lessened from the left of the callee number.
Number of Digits to Strip from Right	The number of digits which are lessened from the right of the callee number.
Prefix to be added	The prefix added to the callee number after its digits are lessened.
Suffix to be added	The suffix added to the callee number after its digits are lessened.
Number of Digits to Reserve from Right	The number of the retained digits which. are counted from the right of the callee number.
Number Type	The type of the callee number. Options include 'Not Config', 'International', 'National', 'Unknown', 'Network Specific', 'Subscriber' and 'Abbreviated'.

4.14.4 PSTN -> PSTN Caller

On the PSTN -> PSTN Caller interface, you can set rules to change the actual caller number during PSTN -> PSTN calling process.

Index	Description	PSTN Group	Callee Prefix	Caller Prefix	Number of Digits to Strip from Left	Number of Digits to Strip from Right	Prefix to Be Added	Suffix to Be Added	Number of Digits to Reserve from Right	Number Type	Presentation Indicator
---	---	---	---	---	---	---	---	---	---	---	---

Total: 0

Click **Add**, and the following interface will be displayed.

PSTN->PSTN Caller Add	
Index	127 ▼
Description	<input type="text"/> *
PSTN Group	Any ▼
Callee Prefix	<input type="text"/> *
Caller Prefix	<input type="text"/> *
Number of Digits to Strip from Left	<input type="text"/>
Number of Digits to Strip from Right	<input type="text"/>
Prefix to Be Added	<input type="text"/>
Suffix to Be Added	<input type="text"/>
Number of Digits to Reserve from Right	<input type="text"/>
Number Type	Not Configured ▼
Presentation Indicator	Not Configured ▼

Parameter	Explanation
Index	The index of this PSTN -> PSTN caller number manipulation, from 0 to 511. Each index cannot be used repeatedly.
Description	The description of this PSTN -> PSTN caller number manipulation.
PSTN Group	Select a PSTN group. The caller number will be manipulated when a call uses a trunk of this PSTN group, actual callee prefix matches the set callee prefix, and actual caller prefix matches the set caller prefix. ‘Any’ means any PSTN group.
Callee Prefix	Set a prefix for the callee number.
Caller Prefix	Set a prefix for the caller number.
Number of Digits to Strip from Left	The number of digits which are lessened from the left of the caller number.
Number of Digits to Strip from Right	The number of digits which are lessened from the right of the caller number.
Prefix to be added	The prefix added to the caller number after its digits are lessened.
Suffix to be added	The suffix added to the caller number after its digits are lessened.
Number of Digits to Reserve from Right	The number of the retained digits which. are counted from the right of the caller number.
Presentation Indicator	If “Allowed” is selected, the calling number will be presented. If “Restricted” is selected, the calling number will not be presented. If “Not Config” is selected, the parameter does not work.
Number Type	The type of the caller number. Options include ‘Not Config’, ‘International’, ‘National’, ‘Unknown’, ‘Network Specific’, ‘Subscriber’ and ‘Abbreviated’.

4.14.5 IP -> PSTN Callee

On the **IP -> PSTN Callee** interface, you can set rules to change the actual callee number during IP -> PSTN calling process.

IP->PSTN Callee												
Index	Description	Trunk Type	IP Trunk	IP Group	Callee Prefix	Caller Prefix	Number of Digits to Strip from Left	Number of Digits to Strip from Right	Prefix to Be Added	Suffix to Be Added	Number of Digits to Reserve from Right	Number Type
---	---	---	---	---	---	---	---	---	---	---	---	---

Total: 0

Click **Add**, and the following interface will be displayed.

IP->PSTN Callee Add

Index	<input type="text" value="511"/>
Description	<input type="text"/>
Source Type	<input type="text" value="Group"/>
IP Group	<input type="text" value="Any"/>
Callee Prefix	<input type="text"/>
Caller Prefix	<input type="text"/>
Number of Digits to Strip from Left	<input type="text"/>
Number of Digits to Strip from Right	<input type="text"/>
Prefix to Be Added	<input type="text"/>
Suffix to Be Added	<input type="text"/>
Number of Digits to Reserve from Right	<input type="text"/>
Number Type	<input type="text" value="Not Configured"/>

Parameter	Explanation
Index	The index of this IP -> PSTN callee number manipulation, from 0 to 511. Each index cannot be used repeatedly.
Description	The description of this IP -> PSTN callee number manipulation.
Source Type	Select PSTN group or PSTN Trunk as source type.
IP Group	Select an IP group. The callee number will be manipulated when a call uses a trunk of this IP group, actual callee prefix matches the set callee prefix, and actual caller prefix matches the set caller prefix. 'Any' means any IP group.
Trunk Type	Select a Trunk type.
Trunk Number	When users select SIP as Trunk type, users need to select a specific SIP trunk.
Callee Prefix	Set a prefix for the callee number.
Caller Prefix	Set a prefix for the caller number.
Number of Digits to Strip from Left	The number of digits which are lessened from the left of the caller number.
Number of Digits to Strip from Right	The number of digits which are lessened from the right of the caller number.
Prefix to be added	The prefix added to the callee number after its digits are lessened.
Suffix to be added	The suffix added to the callee number after its digits are lessened.
Number of Digits to Reserve from Right	The number of the retained digits which. are counted from the right of the callee number.
Number Type	The type of the callee number. Options include 'Not Config', 'International', 'National', 'Unknown', 'Network Specific', 'Subscriber' and 'Abbreviated'.

4.14.6 IP -> PSTN Caller

On the **IP -> PSTN Caller** interface, you can set rules to change the actual caller number during IP -> PSTN calling process.

IP->PSTN Caller													
Index	Description	Trunk Type	IP Trunk	IP Group	Callee Prefix	Caller Prefix	Number of Digits to Strip from Left	Number of Digits to Strip from Right	Prefix to Be Added	Suffix to Be Added	Number of Digits to Reserve from Right	Number Type	Presentation Indicator
---	---	---	---	---	---	---	---	---	---	---	---	---	---

Total: 0

Click **Add**, and the following interface will be displayed.

IP->PSTN Caller Add

Index	<input type="text" value="511"/>
Description	<input type="text"/>
Source Type	<input type="text" value="Group"/>
IP Group	<input type="text" value="Any"/>
Callee Prefix	<input type="text"/>
Caller Prefix	<input type="text"/>
Number of Digits to Strip from Left	<input type="text"/>
Number of Digits to Strip from Right	<input type="text"/>
Prefix to Be Added	<input type="text"/>
Suffix to Be Added	<input type="text"/>
Number of Digits to Reserve from Right	<input type="text"/>
Number Type	<input type="text" value="Not Configured"/>
Presentation Indicator	<input type="text" value="Not Configured"/>

Parameter	Explanation
Index	The index of this IP -> PSTN caller number manipulation, from 0 to 511. Each index cannot be used repeatedly.
Description	The description of this IP -> PSTN caller number manipulation.
IP Group	Select an IP group. The caller number will be manipulated when a call uses a trunk of this IP group, actual callee prefix matches the set callee prefix, and actual caller prefix matches the set caller prefix. 'Any' means any IP group.
Trunk Type	Select a Trunk type.
Trunk Number	When users select SIP as Trunk type, users need to select a specific SIP trunk.
Callee Prefix	Set a prefix for the callee number.
Caller Prefix	Set a prefix for the caller number.
Number of Digits to Strip from Left	The number of digits which are lessened from the left of the caller number.
Number of Digits to Strip from Right	The number of digits which are lessened from the right of the caller number.
Prefix to be added	The prefix added to the caller number after its digits are lessened.
Suffix to be added	The suffix added to the caller number after its digits are lessened.
Number of Digits to Reserve from Right	The number of the retained digits which are counted from the right of the caller number.
Presentation Indicator	If "Allowed" is selected, the calling number will be presented. If "Restricted" is selected, the calling number will not be presented. If "Not Config" is selected, the parameter does not work.
Number Type	The type of the caller number. Options include 'Not Config', 'International', 'National', 'Unknown', 'Network Specific', 'Subscriber' and 'Abbreviated'.

4.15 Voice & Fax

This interface configures parameters related to voice and fax. Users can set the necessary voice parameters to resolve compatibility issues, such as RTP voice parameters, RTP port settings, VAD/CNG, DTMF, PSTN call gain, timeout of no-answer, fax detection, and other parameters.

Voice & Fax Configuration

Voice Parameter

Disconnect call when no RTP packet Yes No

Period without RTP packet s

RTP Start Port

RTP start port must be Multiple of 2048, default value is 6144! Restart to take effect.

Max Call Duration(0 means not limited) min

Rtpcn Period(1-100) s

VAD/CNG ▼

Echo Cancel Time ▼

Gain from PSTN ▼

Gain to PSTN ▼

Ringback Tone Type ▼

Timeout of No Answer(Max Alerting Time)

Call from PSTN(PSTN->IP,PSTN->PSTN) s

Call from IP(IP->PSTN,IP->IP) s

Fax Parameter

Fax Mode ▼

Fax Tx Gain ▼

Fax Rx Gain ▼

Packet time ms

Redundant frame in packet ▼

Local Fax Detection ▼

CED/CNG Detection ▼

T.38 Max Rate bit/s

T.38 Max Datagram

Modem Detection ▼

Busytone Detection ▼

G.711 Li ▼

T30 Auto Switch ▼

Vbd Param ▼

ECM ▼

Data & Fax Control

Data ▼

Fax ▼

DTMF Parameter

Signal Duration ms

Signal Interval ms

Signal Gain ▼

Threshold for Detection ▼

DTMF Advanced Setting

Belong to	Parameter	Explanation
Voice Parameter	Disconnect call when no RTP packet	Options include 'Yes' and 'No'. If 'Yes' is selected, the call will be disconnected when it is detected that the call's silence time is longer than the set maximum time without receiving RTP packets.
	Period without RTP packet	The set maximum time without receiving RTP packets. Default value is 60 seconds.
	RTP Start Port	Minimum value of RTP ports used by the device.
	Max Call Duration(0 means not limited)	Configure the maximum call duration of the device.
	Rtpcn Period (1-100)	Configure the Rtpcn period, ranging from 1 to 100 seconds.
	VAD/CNG	Enable VAD/CNG.
	Echo Cancel Time	The interval to remove echo from a voice communication. Options include 32ms, 64ms and 128ms.
	Gain from PSTN	The voice gain from PSTN to IP direction Default value is -1dB.
	Gain to PSTN	The voice gain from IP to PSTN direction Default value is 2dB.
	Ringback Tone Type	Local ringback tone.
Timeout of No Answer	Call from PSTN	The maximum time of no answer for calls from PSTN.
	Call from IP	The maximum time of no answer for calls from IP Network.
Fax Parameter	Fax Mode	Options include T.38, Pass-through and Adaptive. Default value is T.38. Adaptive means auto negotiate with peer side.
	Fax Tx Gain	Gain of sending a fax.
	Fax Rx Gain	Gain of receiving a fax.
	Packet time	The time for data packing.
	Redundant frame in Packet	The length of frame in RTP packet.

	CED/CNG Detection	Whether to detect CED/CNG.
	T.38 Max Rate	Options: 2400/4800/7200/9600/12000/14400 bps; used to adjust the bit rate of fax
	T.38 Max Datagram	The maximum value of T.38 fax data packet
	Modem Detection	Does SDP with a=modem during pass-through
	Busytone Detection	Enable to interrupt fax when busy tone is detected
	G.711 Li	Whether to disable the recording function when faxing
	T30 Auto Switch	Pass-through Fax control
	Vbd Param	Does SDP with a=vbd during pass-through
	ECM	When enabled, MTG devices use ECM mode.
Data & Fax Control	Data	Whether to enable voice data service on the MTG5000-64E1.
	Fax	Whether to enable fax service on the MTG5000-64E1.
DTMF Parameter	Signal Duration	The duration of a DTMF signal.
	Signal Interval	The interval between two DTMF signals.
	Signal Gain	Configure the gain of sending DTMF.
	Threshold for Detection	The signal detection threshold.
DTMF Advanced Setting	Minimum Detection Period(20-100)	Minimum DTMF detection period for the device, ranging from 20-100s.
	Minimum Detection Interval(40-120)	Minimum DTMF detection interval for the device, ranging from 40-120s.
	Frequency Offset	Detection of DTMF frequency Offset.
	Positive Twist	Detection of DTMF Positive Twist.
	Negative Twist	Detection of DTMF Negative Twist.
	SNR(SIGNAL-NOISE RATIO)	Detection of DTMF Signal-Noise Ratio.
	IP Side DTMF Forwarding Directly	When enabled, the DTMF received by the device on the IP side is forwarded directly.
	Pcm Side DTMF Forwarding Directly	When enabled, the DTMF received by the device on the PCM side is forwarded directly.

4.16 Maintenance

This menu provides the maintenance tools required by the device. The device can support various maintenance tools through web interface, including Ping test, Tracert test, signaling call test, network capture, and debug commands. If users need to get official technical support, users can use these tools to get logs for troubleshooting.

4.16.1 Ping Test

Ping is used to examine whether a network works normally through sending test packets and calculating response time.

Instructions for using Ping:

- 1) Enter the IP address or domain name of a network, a website or a device in the input box of destination, and then click **Start**.
- 2) If related messages are received, it means the network works normally; otherwise, the network is not connected or is connected faultily.

Ping Test	
Destination	<input type="text"/>
Number of Ping(1-100)	<input type="text" value="4"/>
Packet Size(56-1024 bytes)	<input type="text" value="56"/>

Information	

4.16.2 Tracert Test

Tracert Test is used to determine a route from one IP address to another.

Instruction for using Traceroute:

- 1) Enter the IP address or domain name of a destination device in the input box of Destination, and then click Start.
- 2) View the route information from the returned message.

Tracert Test

Destination	<input type="text"/>
Max Hops(1-255)	<input type="text" value="30"/>

Information

--	--	--

4.16.3 Signaling Call Test

On the **Signaling Call Test** interface, you can test whether the signaling of a call is successfully connected. You need to select the source type, trunk type and IP trunk No. of the call, and enter the calling number and called number. If the signaling of a call fails, you can find out where errors have occurred through the messages returned in the **Signaling Trace** box.

Signaling Call test is used to help locate the reason for a failed call. It is used to test the signaling of a **PSTN->IP or PSTN->IP** call and check whether the connection is normal or not.

Signaling Call Test

Source Trunk
Source Type: IP Trunk
Trunk Type: SIP
IP Trunk No.:

Calling Number:
Called Number:

Signaling Trace

4.16.4 Network Capture

On the following interface, you can capture data packages of the available network ports. You can also set source host and destination host to capture the packages that you want.

Note: If there are multiple source or destination IP addresses, please use ‘|’ to separate them, for example, 172.16.115.12|172.16.115.15.

After package capturing is completed, save the captured packages on a computer and then use a tool to analyze them.

Network Capture

Default Setting: Custom
Network Interface: GE1 GE0
Source Host:
Destination Host:
Protocol(s): TCP UDP RTP RTCP ICMP ARP
DTU: DTU None
Capture Size: 4M

4.16.5 Debug Command

At present, only 'closing all' is supported. 'close all' means to close all the tracing.

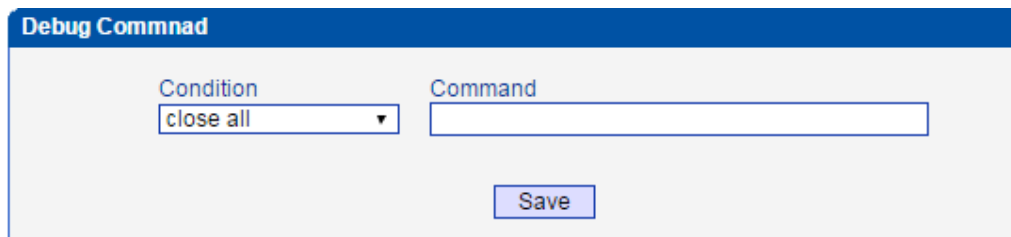

The screenshot shows a web interface titled "Debug Commnad" (note the typo). It features two input fields: "Condition" and "Command". The "Condition" field is a dropdown menu with "close all" selected. The "Command" field is an empty text box. Below these fields is a "Save" button.

4.17 Management

This menu provides various settings required for device management, including basic management parameters, dual MCU Card parameters, license management, data download and restore, user management, firmware upload, password modification, device restart and other management parameters. Network management staffs can use these items to achieve the management of the gateway.

4.17.1 Management Parameter

Management Parameter

WEB Configuration

WEB Default Language Both

HTTPS Port 443

System Parameter

CPU Working Mode Low-Power

E1 Call Limit Configuration

Maximum Number Of Calls 0

Effective Time 0 h

Note: the maximum number of calls or the role of time is 0 on behalf of the function does not take effect!

Access Control

Web Allowed to access GE0 Allowed to access GE1

Ssh Allowed to access GE0 Allowed to access GE1

SYSLOG Configuration

SYSLOG Enable Yes No

Log Type Signal System Management Media

Server IP1

Server IP2

SYSLOG Level NONE

Send CDR Yes No

FILELOG Configuration

FILELOG Enable Yes No

Log Type Signal System Management Media

FILELOG Level NONE

Save CDR Yes No

NATS Server Config

Enable NATS Yes No

Server IP

Server Port 4222

User Name

Password

TLS Enable Yes No

Send CDR To NATS Server Yes No

E1 Auto Close Config

Enable Auto Close Yes No

Judgment By Eth State Sip Server State Register State
 Continuous Call Timeout

Qos

Qos Type None

NTP Configuration

NTP Enable Yes No

Primary NTP Server Address 202.120.2.101

Primary NTP Server Port 123

Secondary NTP Server Address 202.112.0.7

Secondary NTP Server Port 123

Sync Interval 604800 s

Time Zone GMT+8:00 (Beijing, Singapore, Taipei)

Note: the device need restart to take effect after the time synchronization is successful.

Time Setting

Belong to	Parameter	Explanation
WEB Configuration	WEB Default Language	Configure web page display language (Both/ English/ Chinese).
	HTTPS Port	HTTPS port The default port of the HTTPS service is 443.
System Parameter	CPU Working Mode	Configure CPU working mode, such as low power/high performance.
E1 Call Limit Configuration	Maximum Number of Calls	The maximum number of calls within the effective time, 0 means the function does not take effect.
	Effective time	The effective time to limit the maximum number of calls, 0 means the function is not effective, and the E1 call limit configuration takes effect for each E1.
Access Control	Web/Ssh	Options for GE0/GE1 to access web, ssh, telnet
SYSLOG Configuration	SYSLOG Enable	To send logs of the corresponding to the SYSLOG server.
	Log Type	The type of syslog, users can select signal syslog, system syslog, management syslog and media syslog.
	Server IP1	The IP address of the SYSLOG server.
	Server IP2	The IP address of the SYSLOG server.
	SYSLOG Level	Configure Syslog Level, users can set five levels such as NONE, DEBUG, INFO, NOTICE, WARNING.
	Send CDR	When enabled, the device will automatically send CDR to SYSLOG server.
FILELOG Configuration	FILELOG Enable	To save the log of the device, which can be downloaded in the data download.
	Log Type	The type of file log, users can select signal syslog, system syslog, management syslog and media syslog.
	FILELOG Level	Configure FILELOG Level, users can set five levels such as NONE, DEBUG, INFO, NOTICE, WARNING.
	Save CDR	When enabled, the device will automatically send CDR to FILELOG server.
NATS Server	Enable NATS	To send bills to NATS server.

Config	Server IP	Configure NATS server domain name or IP address.
	Server Port	Configure the connection port of NATS server.
	User Name	Configure the authentication username of NATS server.
	Password	Configure the authentication password of NATS server.
	TLS Enable	Enable TLS encrypted transmission.
	Send CDR To NATS Server	When enabled, the device will automatically send CDR to NATS server.
E1 Auto Close Config	Enable Auto Close	E1 port will be automatically closed when the detection conditions are met.
	Judgment By	Configure the basis for E1 Auto Close, such as Eth State, Sip Server State, Register State and Continuous Call Timeout.
Qos	Qos Type	Do not enable /DS, whether to enable Qos service, not enabled by default.
NTP Configuration	NTP Enable	Whether to enable NTP to synchronize the system time, it is enabled by default.
	Primary NTP Server Address	Primary NTP server address.
	Primary NTP Server Port	The default port of the primary NTP server is 123.
	Secondary NTP Server Address	The address of the secondary NTP server.
	Secondary NTP Server Port	The default port of the secondary NTP server is 123.
	Sync Interval	The time period of system detection.
	Time Zone	Select the time zone where the current device is located.
Time Setting	Time Setting	Tick Enable and enter the date and time, the date and time meet the standard, and the set time cannot be too far away from the current time of the device.

4.17.2 Dual MCU Card Parameter

Dual MCU Information

MCU 0

Work Status	Master
GE0 Status	Down
GE1 Status	Up
Software Version	03.06.10.30 p16 2023-02-10 17:17:27
System Uptime	354050s
Complete Mode	<input type="text" value="Auto-negotiation"/>

Common Configuration

Communication with Slave MCU	RPC_FAIL
Slave MCU Debug	<input type="text" value="Disable"/>
Call Sync Delay Time	<input type="text" value="5"/> s
Swap Slave MCU Condition	<input type="radio"/> Enable <input checked="" type="radio"/> Disable

Parameter	Explanation
Slave MCU Debug	If enabled, rpc_trace trace information will be displayed through the slave MCU port.
Call Sync Delay Time	Calls longer than the configured time will be normal after the master/slave MCU switch.
Swap Slave MCU Condition	After enabling, network abnormality triggers the switch of master/slave MCU.
Communication Status	Multiple options (GE0/GE1), unplugging and plugging of the network cable of the master MCU port will trigger the master/slave switch.

4.17.3 Server Parameter

Server Parameter

Authentication Configuration

Authentication Enable Yes No

Server1

Server IP Address1

KeepAlive Port1

Authentication Port1

CDR Port1

Server2

Server IP Address2

KeepAlive Port2

Authentication Port2

CDR Port2

Custom Domain

Send CDR

Record Configuration

Record Enable Yes No

Server IP Address

Rcd Port

Max Path

Rcd Period Select

Rcd Mode

Rcd Start when

Rcd Send by

If Type

NAT

Recognition Configuration

Recog Enable Yes No

Server IP Address

Recog Port

Max Path

Belong to	Parameter	Explanation
Authentication Configuration	Authentication Enable	After enabling, the device will authenticate the server and send call bills.
	Server IP Address	Configure the IP address of the authentication server.
	KeepAlive Port	Configure the KeepAlive Port of the authentication server.
	Authentication Port	Configure the Authentication Port of the authentication server.
	CDR Port	Configure the CDR Port of the authentication server.
	Custom Domain	Configure the Custom Domain of the authentication server.
	Send CDR	When enabled, the device will automatically send CDR to authentication server .
Record Configuration	Recording Enable	After enabling, the device sends the media stream to the recording server to generate a recording file.
	Server IP Address	Configure the IP address of the recording server.
	Rcd Port	Configure the port of the recording server, which usually is 2999.
	Max Path	Maximum number of concurrent recordings.
	Rcd Period Select	Configure the time interval for recording.
	Rcd Mode	Configure recording mode.
	Rcd Start when	Configure the recording start time, including connect/alert; if recording starts from connect, the recording file will only contain the call conversation after the call is taken, if recording starts from alert, the recording file will contain the ringback tone before the call is taken.
	Rcd Send by	Configure the interface for sending recordings.
	If Type	Type of interface, including media/management.
NAT	Disable/enable NAT; when enabled, the RTP stream is forwarded to the configured server IP; when disabled, the RTP stream is forwarded to the address carried by the recording server start ack message	
recognition configuration	Enable voice recognition.	After enabling, the device sends the media stream to the recognition server for voice

		recognition.
	Server IP Address	Configure the IP address of the recognition server.
	Recog Port	Configure the port of the recognition server.
	Max Path	Maximum concurrent for language recognition

4.17.4 Cloud Server

User can register the MTG5000-64E1 device to cloud server, and then the gateway will be managed by cloud server.

Cloud Server

Domain

Port

Password

Parameter	Explanation
Domain	The address of the cloud server, the public network cloud server is www.dmclcd.com
Port	The port to connect to the cloud server, the public network cloud server port is 2020.
Password	Password can be empty.

4.17.5 NMS Server

User can register the MTG5000-64E1 device to NMS server and use NMS services.

NMS Service

NMS Enable

NMS Server Address

NMS Server Port

NMS Local Interface ▼

Parameter	Explanation
NMS Server Address	Configure the IP address of NMS Server.
NMS Server Port	Configure the port of NMS Server.
NMS Local Interface	Configure the local interface of NMS Server.

4.17.6 Mail Server

After enabling the mail service, it can send device alarm emails to specific recipients through email servers such as Tencent email service.

Mail service configuration

Enable

SMTP Server

Sender

Password

Recipient

Recipient2

Recipient3

Enable SSL

Mail Content Options

E1 Status

SS7 Link Status

Device Restart

SIP Account Register Status

Web Login Fail More Than 3 Times

PRI Link Status

SIP Trunk Status

Wan IP Update

Cloud Register Status

Parameter	Explanation
SMTP Server	Email server address (such as smtp.163.com).
Sender	The sender of the alert email (need to enable SMTP).
Password	Authorization password of the sender.
Recipient	Recipient email address.
Enable SSL	The mail is encrypted via SSL.
Email Content Options	Select the subject of the message.

4.17.7 SNMP Parameter

SNMP is a network management standard based on the TCP/IP protocol suite. It is a standard protocol for managing network nodes (such as servers, workstations, routers, switches, etc.) in an IP network. SNMP can enable network administrators to improve network management efficiency, discover and solve network problems in time. Network administrators can also receive notification messages from network nodes and alarm event reports through SNMP to learn network problems. After the device is connected to the SNMP server, you can view and set of the device on the SNMP server, and view the device alarms.

SNMP Parameter

SNMP Enable Yes No

SNMP Version

SNMP Listen Port
Notice:SNMP default listen port is 161.The device must restart to take effect after changing port!

User Configuration

	User	AuthType	AuthPassword	PrivacyType	PrivacyPassword
1st	<input type="text"/>	<input type="text"/>	<input type="text"/>	<input type="text"/>	<input type="text"/>

Notice:The length of AuthPassword and PrivacyPassword are more than 8!

Group Configuration

	Community
1th	<input type="text"/>

View Configuration

	ViewName	ViewType	ViewSubtree	ViewMask
1st	<input type="text" value="all"/>	<input type="text" value="included"/>	<input type="text" value=".1"/>	<input type="text"/>
2nd	<input type="text"/>	<input type="text"/>	<input type="text"/>	<input type="text"/>
3rd	<input type="text"/>	<input type="text"/>	<input type="text"/>	<input type="text"/>

Notice: ViewSubtree style:x.x.x.x.x.if just one,style:x

Access Configuration(v3)

	Group	sec.level	Read	Write	Notify
1th	<input type="text"/>	<input type="text"/>	<input type="text"/>	<input type="text"/>	<input type="text"/>

Notice:Read/Write/Notify value reference to ViewName.If Read/Write/Notify want to have value,please firstly sielect Group.

Trap Configuration

	TrapFlag	TrapIP	TrapPort	TrapCommunity
1st	<input type="text"/>	<input type="text"/>	<input type="text" value="0"/>	<input type="text"/>

1. The only one is effective between v1 and v2c.

Belong to	Parameter	Explanation
SNMP Version	SNMP Version	v1/v2c/v3
Trap Language	Trap Language	The voice of the alarm message in the trap sent by the device, users can choose English/Chinese
SNMP Listen Port	SNMP Listen Port	The device SNMP listening port is 161 by default, and it will take effect after modification.
User Configuration	User	Same as the user name set on the SNMP server.
	Auth Type	MD5/SHA, consistent with the setting on the SNMP server.
	Auth Password	The password is consistent with the setting on the SNMP server.
	Privacy Type	DES/AES/AES128, consistent with the setting on the SNMP server.
	Privacy Password	The password is the same as that set on the SNMP server.
Group Configuration	Group	Custom group name .
	Community	The community configured above.
View Configuration	View Name	Custom
	View Type	included/excluded
	View Subtree	The Root OID of the Mib Subtree, in the format x.x.x.x.x. If there is only one x, the format is x.
	View Mask	The mask and the OID of the mib tree are expressed in hexadecimal to determine the range of a view. After translating into binary, each bit corresponds to a bar in the OID. 1 means exact match, and 0 means general.
Access Configuration (v3)	Group	Choose a group name from the ones configured above.
	Sec. Level	Authnopriv/authpriv, the encryption type and encryption password will be empty. When the security level is authpriv, the encryption type and encryption password will be empty.
	Read	Select from the configured views above.
	Write	Select from the configured views above.

	Notify	Select from the configured views above.
Trap Configuration	Trap Flag	V1/V2c/inform
	Trap IP	The address of SNMP trap.
	Trap Port	SNMP trap port.
	Trap Community	Consistent with the configuration of the SNMP platform, it can be empty.

4.17.8 Radius Parameter

The RADIUS server is responsible for receiving the user's connection request, authenticating the user, and then returning all the necessary configuration information to send the service to the user. After the device is connected to the radius server, it can authenticate the device login and charge the device call.

Radius Configuration

RADIUS Enable Disable Acct Auth Auth&&Acct

Radius Port

Max Retry

TimeOut(1~10s)

Connect Fail Count

Server Recover Time(1~30min)

Device Behavior Upon RADIUS Timeout ▼

Primary Server IP

Primary Server Auth Port

Primary Server Acct Port

Primary Server Key

Second Server IP

Second Server Auth Port

Second Server Acct Port

Second Server Key

NOTE: The device must restart to take effect.

Parameter	Explanation
RADIUS Enable	Select RADIUS service: Disable/ Acct/ Auth/ Acct&Auth.
Radius Port	The port for connection and communication between the device and the radius server (the default is 1813).
Max Retry	The number of retry when the device does not receive a reply after sending a radius request.
Timeout (1~10 seconds)	The time interval between no reply after the device sends a radius request and retransmission of the radius request.
Connect Fail Count	Only used in Acct mode, and the configured count of connect fail does not receive a response, and the device automatically sets the radius server to the dead state.
Server Recovery Time (1~30 min)	After setting the recovery time, the radius server status changes from dead to active.
Device Behavior Upon RADIUS Timeout	Local verification/login refused; local verification–radius server authentication timeout, verify whether the user name and password are consistent with the registered, if they are, the access to the device is successful, if not, the user name/password error will be prompted. Login is refused–Radius server authentication timeout directly denies access, prompting user name/password error.
Primary Server IP	Primary radius server address.
Primary Server Auth Port	Primary radius server authentication port.
Primary Server Acct Port	Primary radius server Acct port.
Primary Server Key	Master radius server key.
Second Server IP	Second radius server address.
Second Server Auth Port	Second radius server authentication port.
Second Server Acct Port	Second radius server Acct port.
Second Server Key	Second radius server key.

4.17.9 Remote Server

After connected to the server, you can log in to the web management platform of the device through the server.

Remote Server

Enable	<input checked="" type="checkbox"/>
Server URL/IP	<input style="width: 90%;" type="text"/>
Server Port	<input style="width: 90%;" type="text"/>

4.17.10 Data Download

Through data download, service data, system logs, call logs, userboard logs, etc. can be saved to the local computer.

Service Data Backup

Click 'Backup' to download Database file to your computer.	<input type="button" value="Backup"/>
Click 'Backup' to download Dialplan file to your computer.	<input type="button" value="Backup"/>
Click 'Backup' to download Sip Account file to your computer.	<input type="button" value="Backup"/>
Click 'Backup' to download Number Bound TsNo List file to your computer.	<input type="button" value="Backup"/>
Click 'Backup' to download User Account Info file to your computer.	<input type="button" value="Backup"/>
Click 'Backup' to download User Group Info file to your computer.	<input type="button" value="Backup"/>

System Log Download

Click 'Backup' to download Exception file to your computer.	<input type="button" value="Backup"/>
Click 'Backup' to download Snapshot file to your computer.	<input type="button" value="Backup"/>
Click 'Backup' to download System Log file to your computer.	<input type="button" value="Compre"/>
Click 'Backup' to download Management Log file to your computer.	<input type="button" value="Compre"/>
Click 'Backup' to download Emergency Log file to your computer.	<input type="button" value="Compre"/>
Click 'Backup' to download User Operation file to your computer.	<input type="button" value="Compre"/>
Click 'Backup' to download Remote Log file to your computer.	<input type="button" value="Backup"/>

Call Log Download

Click 'Backup' to download Cdr file to your computer.	<input type="button" value="Compre"/>
Click 'Backup' to download Signal Log file to your computer.	<input type="button" value="Compre"/>
Click 'Backup' to download Media Log file to your computer.	<input type="button" value="Compre"/>

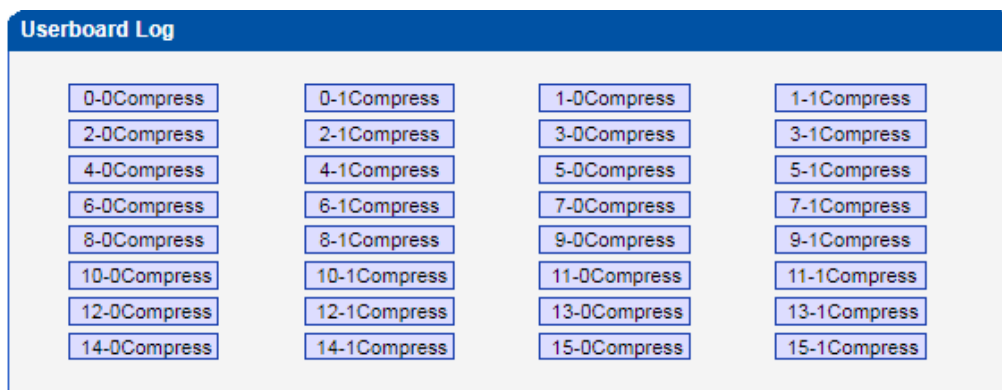

4.17.11 Data Restore

On the **Data Restore** interface, you can restore database, dialplan, SIP account and so on. If you upload a file that contains default configurations, the MTG5000-64E1 will be restored to default configurations. You can also upload a dialplan file to restore dialing rules.

Database herein refers to the database where configuration data are placed.

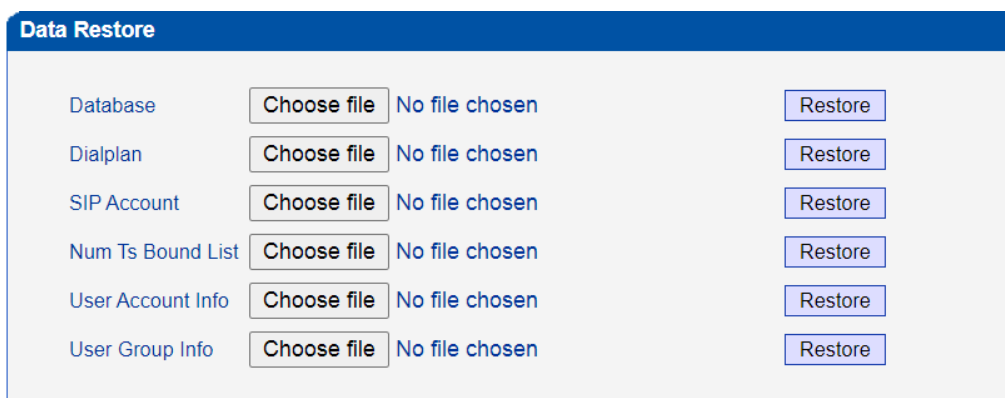

4.17.12 License Management

On the **License Management** interface, the information of license is displayed.

License Information	
License SN	5
Device SN	5000-0000-1111-6062
Hardware SN	7cd7-5347-262b
License Type	Official
License Version	1.15
License Create Time	2021-07-14 10:41:07.272940207 +0800 CST m=+33.931868...
Available E1 Number	5000-64E1/T1
SS7 Module	enable
PRA Module	enable
R2 Module	enable
PSTN2PSTN Module	enable
IP2IP Module	enable
G729 Call	2048
G723 Call	2048
ilbc Call	2048

refresh

License Setting	
License Key	<input type="text"/>

save

4.17.13 Version Information

On the **Version Information** interface, the version information of the software, database, Web, FPGA, DSP and DTU boards are displayed.

Version Information			
File Type	Version	Date Built	Time Built
Software	3.06.10.30	2023-02-10	17:18:28
Database	2.03.28	2022-01-05	15:30:00
Web	3.06.10.30	2023-02-10	17:18:31
FPGA	1.02.11	2016-06-03	18:22:04
UserBoard ipk	board_1.2		
UserBoard image	h8users.41		

CardDTU Version Info		
Description	Slot Num	Current Version
DTU2B-0	0	board1.2-02.17.41-00
DTU2B-1	1	board1.2-02.17.41-00
DTU2B-2	2	board1.2-02.17.41-00
DTU2B-3	3	board1.2-02.17.41-00
DTU2B-4	4	board1.2-02.17.41-00
DTU2B-5	5	board1.2-02.17.41-00
DTU2B-6	6	board1.2-02.17.41-00
DTU2B-7	7	board1.2-02.17.41-00
DTU2B-8	8	board1.2-02.17.41-00
DTU2B-9	9	board1.2-02.17.41-00
DTU2B-10	10	board1.2-02.17.41-00
DTU2B-11	11	board1.2-02.17.41-00
DTU2B-12	12	board1.2-02.17.41-00
DTU2B-13	13	board1.2-02.17.41-00
SWDTU	16	v5.01.07

4.17.14 Firmware Upload

On the **Applications Upload** interface, you can upload files to upgrade the software, the Web, and the Mod file of MTG5000-64E1. If you select ‘Package’, it means the upgrading files of the software and Web are packaged and then uploaded.

Applications Upload

Select Package ▾

Package Choose file No file chosen Upload

NOTES: The device must restart to take effect after uploading.

Firmware Upload

Select Boot ▾

Boot Choose file No file chosen Upload

NOTES: The device must restart to take effect after uploading.

Note: Do not upgrade the underlying files yourself.

Cards Update

Select UserBoard ipk ▼

UserBoard ipk Choose file No file chosen Upload

Standby Software Transmit

Package Db Transmit

File TransMit Result:

Belong to	Parameter	Explanation
Applications Upgrade	Package	Select the package to be loaded (<i>mtgpackage.ldf</i>), and click Upload. The package contains app and web. There is no need to reload the app or web program. After the loading is successful, restart the device.
	Software	Select the app program to be loaded (<i>mtgapp.ldf</i>), and click Upload. After the upload is successful, the supporting web program will be loaded.
	Web	Select the <i>mtgweb.ldf</i> to be loaded, and click Upload. After the app and web are loaded successfully, restart the device.
	Mod File	Select <i>recog.mod</i> to be loaded, click Upload, and restart the device after uploading successfully.
	Tcpdump	Select the <i>tcpdump (linux program)</i> to be loaded, click upload, and restart the device after the upload is successful.
	Certificate	Select the CA certificate file to be loaded, click Upload, and restart the device after the upload is successful.
Firmware Upgrade	Boot	Select the <i>mtgboot.ldf</i> file to be loaded. After the upload is successful, the <i>telnet</i> device enters <i>^config</i> , executes <i>uboot update</i> , and restarts the device after the prompt “update uboot success”.
	Kernel	Select the <i>mtgkernel.ldf</i> file to be loaded. After the upload is successful, the <i>telnet</i> device enters <i>^config</i> , executes the <i>kernel update</i> , and restarts the device after the prompt “update kernel success”.
	File System	Select the <i>mtgfs.ldf</i> file to be loaded. After the

		upload is successful, the <i>telnet</i> device enters <i>^config</i> , executes <i>license update</i> , <i>netinfo backup</i> , save the license and network information of the device, and then execute <i>fs update</i> . After the <i>fs</i> is refreshed (Do not operate the web and do not use the web to restart the device). You can log in to the reboot device with SSH, or <i>reset</i> the device in <i>^config</i> mode.
	FPGA Firmware	Upload the selected <i>mtgfpga.ldf</i> and restart the device to take effect after the upload is successful.
	DSP Firmware	Upload the selected <i>mtgdsp.ldf</i> and restart the device to take effect after the upload is successful.
	DSP827 Firmware	Upload the selected <i>dsp827app.ldf</i> and restart the device to take effect after the upload is successful.
	Authorization	Upload the selected <i>mtgauth.ldf</i> and restart the device to take effect after the upload is successful.
	Module	Upload the selected audio file and restart the device to take effect after the upload is successful.
Cards Update	User Board ipk	Upload the selected user board program and restart the device to take effect after the upload is successful.
	User Board image	Upload the selected user board program and restart the device to take effect after the upload is successful.
Standby Software Transmit	After selecting the software package and database, click Synchronize ; the software package can only synchronize the uploaded package files; the program can be synchronized after the master/slave MCU synchronization is successful.	

4.17.15 User Account Management

Account management							
Index	UserName	User Group No	Last Logon Date	Account Inactive	Auto-Lock	Lock Time	
<input type="checkbox"/>	0	admin	0	2023- 2-15	No	No	-
<input type="checkbox"/>	1	maintance	1	2021- 7-12	Yes	No	-
<input type="checkbox"/>	2	monitor	2	2021- 7-12	Yes	No	-

Account Add

Index

User Group No

UserName

Password

Confirm Password

Parameter	Explanation
Index	Account index, 32 accounts can be configured, account 0 cannot be modified or deleted.
User Group No	The account in which the group.

4.17.16 User Group Management

Account Group management															
Index	Group Name	Network Param Config	PRI Config	SS7 Config	PSTN Group Config	SIP Config	IP Group Config	Number Filter	Call Routing	Number Manipulation	Voice & Fax	Maintenance	Management	User Management	
<input type="checkbox"/>	0	admin	RW	RW	RW	RW	RW	RW	RW	RW	RW	RW	RW	RW	
<input type="checkbox"/>	1	mainta...	RW	RW	RW	RW	RW	RW	RW	RW	RW	RW	RW	NA	
<input type="checkbox"/>	2	monitor	R	R	R	R	R	R	R	R	R	R	R	NA	

Account Add

Index	3
GroupName	<input type="text"/>
Status & Statistics	ReadWrite
Network Param Config	ReadWrite
PRI Config	ReadWrite
SS7 Config	ReadWrite
PSTN Group Config	ReadWrite
SIP Config	ReadWrite
IP Group Config	ReadWrite
Number Filter	ReadWrite
Call Routing	ReadWrite
Number Manipulation	ReadWrite
Voice & Fax	ReadWrite
Maintenance	ReadWrite
Management	ReadWrite
SDH Config	ReadWrite
Encrypt Config	ReadWrite
R2 Config	ReadWrite
Username Length Range	6 - 32
Password Length Range	6 - 22
Inactive after a period of logout time	93 day
Auto-lock ater failed logins(count/period)	5 / 30 min
Locking time for Auto-lock	30 min

NOTE: 1.The account will turn to inactive status after a period of logout time.
 2.Login failed several times in a row, the account will be locked.

Parameter	Explanation
Index	Account group index, 8 account groups can be configured, account 0 cannot be modified or deleted.
GroupName	Description of account group name.
Permissions	ReadWrite/ ReadOnly/ None.
UserName Length Range	Limit the length of the password username (The front bit cannot be length than the later).
Password Length Range	Limit the length of the password (The front bit cannot be length than the later).
Inactive after a Period of Logout Time	When the account is not logged in or used within the configured time (the device has not been restarted), the account into dormant and cannot be used。 the account will go to sleep and cannot be used.
Auto-lock after Failed Login (count/period)	The number of consecutive login failures within the configured period. If more than the preset number, the account will be locked and cannot be logged in.
Locking Time for Auto-lock	Set the account lock time, and the account will be automatically unlocked after the preset time is reached.

4.17.17 Password Modification

On the **Password Modification** interface, you can modify password for logging in the MTG5000-64E1 device. Default password is admin@123#, so it is advised to modify it for security consideration.

The above and mentioned password is also used to log in Web Interface, Telnet and SSH.

Password Modification

Old Password

New Password
8~21 characters and is case sensitive

Confirm Password
Please fill in the password again

4.17.18 Auto Reset

Auto Reset Config

Enable

Reset Mode

Protective Reset

Reset Interval d

Reset Time(0-23) o'clock

NOTE: Protective reset will detects if a call is currently active.
 The time is based on the device system time.

Parameter	Explanation
Reset Mode	Timed restart/delayed restart; timed restart is a cyclic restart, and delayed restart is a one-time restart.
Protective Reset	Protective restart will detect whether there is current calls within the time range, and restart the device when there is no calls; otherwise, the device will be forced to restart within the last time.
Reset Interval	The time of the interval between two restarts
Reset Time (0-23)	The time of each restart

4.17.19 Device Restart

Click the **Restart** button, and you can restart the MTG5000-64E1 device.

Device Restart

Click the 'Reset' button below to restart the device
In dual master mode, Click the 'BothRst' button below to restart the device

5 Abbreviation

Abbreviation	Full Name
PRI	Primary Rate Interface
DND	Do-not-Disturb
FMC	Fixed Mobile Convergence
SIP	Session Initiation Protocol
DTMF	Dual Tone Multi Frequency
USSD	Unstructured Supplementary Service Data
PSTN	Public Switched Telephone Network
STUN	Simple Traversal of UDP over NAT
IVR	Interactive Voice Response
IMSI	International Mobile Subscriber Identification Number)
IMEI	International Mobile Equipment Identity
DMZ	Demilitarized Zone

6 Commands

6.1 Commands under en Mode

This section is aimed to guide customers to get more details of MTG5000-64E1 gateway through command lines. It introduces the command lines that are commonly used.

6.1.1 Login Command

Run the PuTTY, and login MTG5000-64E1 gateway through Telnet. Enter username and password, and then run command en to activate the privileged commands.

```
Welcome to Command Shell!
Username:admin
Password:*****
ROS>en
ROS#
```

6.1.2 Query IP Address

Enter the command **show int**, IP address, MAC address and Netmask of GE1 are displayed.

```
ROS#show int
eth0  Link encap:Ethernet HWaddr 00:5A:4E:56:38:04 MAC
      IP Address
GE1   inet addr:172.16.222.2 Bcast:172.16.255.255 Mask:255.255.0.0
      Netmask
      UP BROADCAST RUNNING MULTICAST MTU:1400 Metric:1
      RX packets:222562 errors:0 dropped:0 overruns:0 frame:0
      TX packets:71386 errors:0 dropped:0 overruns:0 carrier:0
      collisions:0 txqueuelen:532
      RX bytes:66441300 (63.3 MiB) TX bytes:23649487 (22.5 MiB)
      Interrupt:11
```

6.1.3 Query Statistics about DTU

Enter the command **show card**, and statistics about DTU are displayed.

```
ROS#show card
CardNum RemoteMAC ConnectState LinkOk queue RegCnt LastRegTick CurTick LastOffTick LinkFailCnt Version
0 00-11-22-33-44-01 Active OK 0 1 10309 2347576 0 0 v2.01.11
1 00-11-22-33-44-11 Active OK 0 1 10786 2347576 0 0 v2.01.11
2 00-11-22-33-44-21 Active OK 0 1 11262 2347576 0 0 v2.01.11
3 00-11-22-33-44-31 Active OK 0 1 11739 2347576 0 0 v2.01.11
4 00-11-22-33-44-41 Active OK 0 1 12214 2347576 0 0 v2.01.11
```

6.1.4 Query DSP Information

Enter the command **show dsp info**, and DSP information is displayed.

```

ROS#show dsp info
Dsp No:0,          Status:DSP_LOADING_INIT_SUCCESS
                  Dsp Cap:2480
                  Dsp Mac:00-11-22-33-44-02
                  Ip Address:172.30.20.4
                  Arm version:Branch_7_25_K2
                  Load Fail Count:0
                  Cmd NoResponse Count:0
=====
Dsp No:1,          Status:DSP_LOADING_INIT_SUCCESS
                  Dsp Cap:2480
                  Dsp Mac:00-11-22-33-44-03
                  Ip Address:172.30.20.4
                  Arm version:Branch_7_25_K2
                  Load Fail Count:0
                  Cmd NoResponse Count:0
=====
Dsp No:2,          Status:DSP_LOADING_INIT_SUCCESS
                  Dsp Cap:2480
                  Dsp Mac:00-11-22-33-44-12
                  Ip Address:172.30.20.4
                  Arm version:Branch_7_25_K2
                  Load Fail Count:0
                  Cmd NoResponse Count:0
=====

```

6.1.5 Query CPU Performance

Enter the command **show perf**, the CPU performance is displayed.

```

ROS#show perf
performance now :0
performance 5s :0
performance 60s :0
performance 600s:0

performance now user(%%):0
performance now system(%%):0

```

Performance now	CPU load at current time
Performance 5s	Average CPU load in recent 5 seconds
Performance 60s	Average CPU load in recent 60 seconds
Performance 600s	Average CPU load in recent 600 seconds

6.1.6 Query SS7 Trunk Status

Enter the command **show ss7 sta**, and the status of SS7 link is displayed.

```

ROS#show ss7 sta
  grpId linkState mainLink backupLink currentCalls maxCalls failCalls tot
alCalls failRatio
-----

```

6.1.7 Query SS7 Link Statistics

Enter the command **show ss7 link**, and statistics about SS7 link are displayed.

```

ROS#show ss7 link
  linkId hdlcNo type revErrs cc rc lsc iac poc txc aerm suerm
  daedt daedr
-----

```

6.1.8 Query SS7 Call Statistics

Enter the command **show ss7 call**, and statistics about SS7 calls are displayed.

```

ROS#show ss7 call
grpId: interface ID   userId: CC call ID   callId: SS7 call ID
online total calls: 0

```

6.1.9 Query SS7 Errors

Enter the command **show ss7 err**, and errors about SS7 trunks or SS7 links are displayed.

```

ROS#show ss7 err
error cnt:14
[07-15 11:06]erro - hard_init()->tm_connect_ss7_e1 failed!
[07-15 11:06]erro - hard_init()->tm_connect_ss7_e1 failed!
[07-15 11:07]erro - hard_init()->tm_connect_ss7_e1 failed!
[07-15 11:07]erro - hard_init()->tm_connect_ss7_e1 failed!
[07-15 11:07]erro - hard_init()->tm_connect_ss7_e1 failed!
[07-15 11:07]erro - hard_init()->tm_connect_ss7_e1 failed!
[07-15 11:07]erro - hard_init()->tm_connect_ss7_e1 failed!
[07-15 11:07]erro - hard_init()->tm_connect_ss7_e1 failed!
[07-15 11:08]erro - hard_init()->tm_connect_ss7_e1 failed!
[07-15 11:08]erro - hard_init()->tm_connect_ss7_e1 failed!
[07-15 11:08]erro - hard_init()->tm_connect_ss7_e1 failed!
[07-15 11:08]erro - hard_init()->tm_connect_ss7_e1 failed!
[07-15 11:08]erro - hard_init()->tm_connect_ss7_e1 failed!
[07-15 11:08]linkId[2] erro - ###-- Error: Abnormal Flag -> 127 <= 21 <= 127
[07-15 11:08]linkId[2] erro - ss7_pkt_discard()->fsn error! previous:51 ,new:127 len:6

```

6.1.10 Query PRI Trunk Status

Enter the command **show q931 sta**, and statuses of PRI trunks are displayed.

```

Welcome to Command Shell!
Username:admin
Password:*****
ROS>en
ROS#show q931 sta
SHOW ALL PRAs DETAIL CALL STATISTIC INFORMATION
ROS#

```

6.1.11 Query PRI Link Statistics

Enter the command **show q931 link**, and PRI link statistics are displayed.

```

ROS#show q931 link
  PRA E1No.  COMPORT STATE      STATUS
d   own_cmd   own_resp   qlen          v_s v_a v_r pst peer_cm
-----
online total links: 0
ROS#

```

6.1.12 Query PRI Call Statistics

Enter the command **show q931 call**, and statistics about PRI calls are displayed.

```

ROS# show q931 call
SHOW ALL PRAs INFORMATION
CR: Q931 CALL REFERENCE SC:SHOW CALLING NUMBER
UID: EIA NO <<16 | PORT NO or 0x200 << 16 | ST CR
ROS#

```

6.1.13 Query Packet Statistics of HDLC Channel and Related Error Codes

Enter the command **show mcc x** (x refers to the port No. of HDLC channel), and the packet statistics and error codes (if there are any) of the HDLC channel are displayed.

```

ROS#show mcc x
----HDLC channel 0 Info ----
chan0 send frames num = 0.
chan0 recv frames num = 0.
ROS#

```

6.1.14 Query Status of E1 Port

Enter the command **show e1 x** (x refers to the E1 port No.), and the status of the E1 port is displayed.

```

ROS#show e1 x
E1No=0 E1OkFlag=0, enable , IsUsed=0(none-255), LineState=0xa3, Framing_Err_Nu
m=0, Code_Violation_Num=0, E-bit_Err_Num=0, RX_CRC_Err_Num=0.
Set Remote Clock Source Port:0 at Card:0.
ROS#

```

6.1.15 Query Statistics of All Call

Enter the command **show cc call**, and the statistics of all calls are displayed.

```

ROS#sh cc call
No  Ci  Cr1 Cr2  State  Term1 Term2 Trunk1 Trunk2 S_time  V1k St1 Room1 Room2 RfPt1 RfPt2 Calling  Called
-----Total 0 lines-----

Max :2, Current :0

TrunkType  TrunkNo  CallsNum
-----

----- cc statistics -----
CR exception :0
CCB exception :0
Exceed max call duration :0
No voice protect :0
Call routine check error :0
SIP trunk disconnected :0
Calls release by SIP trunk fault :0
Calls release by DSP fault :0
Calls release by PSTN fault :0
Calls release by no SIP response:0
ROS#

```

6.2 Commands under config Mode

6.2.1 Login Commands

```

Welcome to Command Shell!
Username:admin
Password:*****
ROS>en
ROS#
ROS#^config
ROS(config)#

```

6.2.2 Other Commands

Used For/To	Command
Query version information	ROS(config)# load show
Call tracing	ROS(config)#deb cc detail all ROS(ada)#turnon 27
SIP signal tracing	ROS(config)#deb sip msg all ROS(ada)#turnon 71
Query SS7 Signal	ROS(config)#deb ss7 <lnkId> <level> ROS(ada)#turnon 96
Query PRI Signal	ROS(config)#deb q931 detail ROS(ada)#turnon 64
Restart MTG5000-64E1	ROS(config)#reset gmpu [ipaddr]

6.3 Commands under ada Mode

6.3.1 Login Commands

```

Welcome to Command Shell!
Username:admin
Password:*****
ROS>en
ROS#
ROS#^ada
ROS(ada)#[119-17:35:18:040]ADA CONNECTED ...,WELCOME!
ROS(ada)#
    
```

Used For/To	Command
Query the records about exceptions or errors	ROS(ada)#cmd 3 30 0
Query the records about exceptions or errors before the restart of MTG5000-64E1	ROS(ada)#cmd 3 30 1
Disable the printing of SIP messages	ROS(ada)#turnoff 71
Disable the printing of SS7 messages	ROS(ada)#turnoff 96
Disable the printing of PRI messages	ROS(ada)#turnoff 64
Disable the printing of CC messages	ROS(ada)#turnoff 27