

# Quick Installation Guide

- ☑ MTG200
- ☑ MTG1000
- ☑ MTG2000B
- ☑ MTG2000
- ☑ MTG3000
- ☑ MTG5000

## **THANKS FOR CHOOSING DINSTAR'S TRUNK GATEWAY!**

Please read this guide carefully before installing the gateway. If you need any technical support, please contact us.

Tel: +86 755 61919966

Email: [support@dinstar.com](mailto:support@dinstar.com)

Web: [www.dinstar.com](http://www.dinstar.com)

# 1 Product Models & Number of E1/T1 Ports

E1/T1 Ports Models	1	2	4
MTG200	✓	✓	✓
MTG1000	✓	✓	/

Port Number Models	Number of E1/T1 Ports (Single DTU Board)	Number of DTU Boards	Maximum number of E1/T1 ports
MTG2000B	4	4	16
MTG2000	4	5	20
MTG3000	16	4	63
MTG5000	4	16	64

- The number of E1/T1 ports of MTG2000 Series, MTG3000, and MTG5000 are determined by the number of inserted DTU boards. In addition, MTG3000 only provides up to 63 E1/T1 ports because the channel overhead and other configurations need to take up more bandwidth.
- Please confirm your product model before installation and follow the installation guidelines for the model.

## 2 Description of Indicators

### (1) MCU Board and DTU Board

Indicator	Definition	Status	Description
PWR	Power Indicator	On	The gateway is powered on
		Off	The gateway has no power input or power supply is abnormal
RUN	Running Indicator	Slow Flashing	The gateway is running properly
		Off	The gateway is initiated improperly
E1/T1	E1/T1 In-use Indicator	On	E1/T1 port is connected properly.
		Off	E1/T1 port is faulty or not connected
		Flashing	The physical connection of E1/T1 is abnormal or there are error codes in the E1/T1 circuit
GE	Network Link Indicator	Green Flashing	The gateway is properly connected to the network
		Off	The gateway is not connected to the network or the network connection is in an improper way
	Network Speed Indicator	On	Work at 1000Mbps
		Off	Network speed lower than 1000Mbps

LINK	MCU Board Link Indicator	On	The DTU board is properly connected to the MCU board
		Off	The DTU board is not or improperly connected to the MCU board, or the DTU board is faulty

## (2) SDH Board

Indicator	Definition	Status	Description
PWR	SDH Board Power Indicator	On	The gateway is powered on
		Off	The gateway is powered off or there is no power supply
RUN	SDH Board Running Indicator	Slow Flashing	The gateway is running properly
		Fast Flashing	If there is a SIP account registered successfully, the indicator is fast flashing
Light 0 /Light 1	SFP Optical Module Link Indicator	On	The SFP optical module has been inserted into the SFP port 0/port 1
		Off	The SFP optical module has not been yet inserted into the SFP port 0/port 1

## 3 Indicators & Interfaces

### ► MTG200

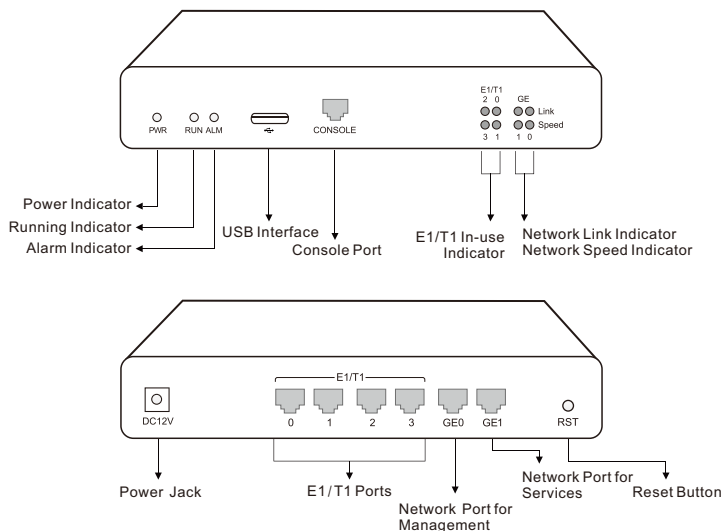

## ▶ MTG1000

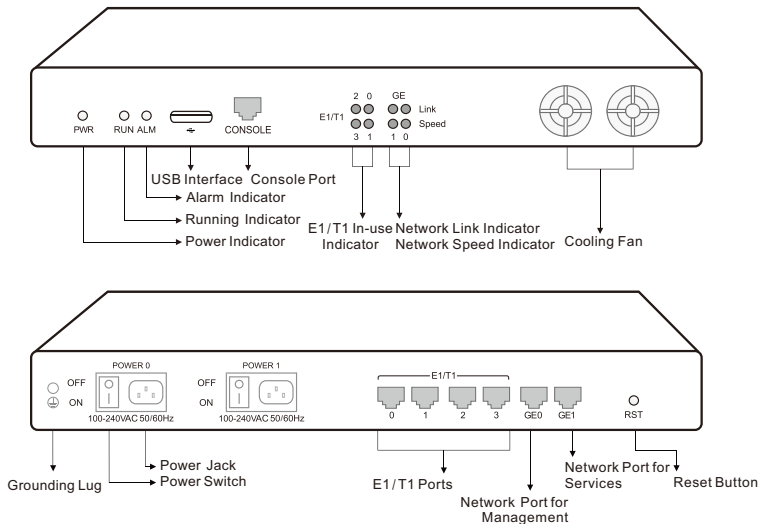

## ▶ MTG2000

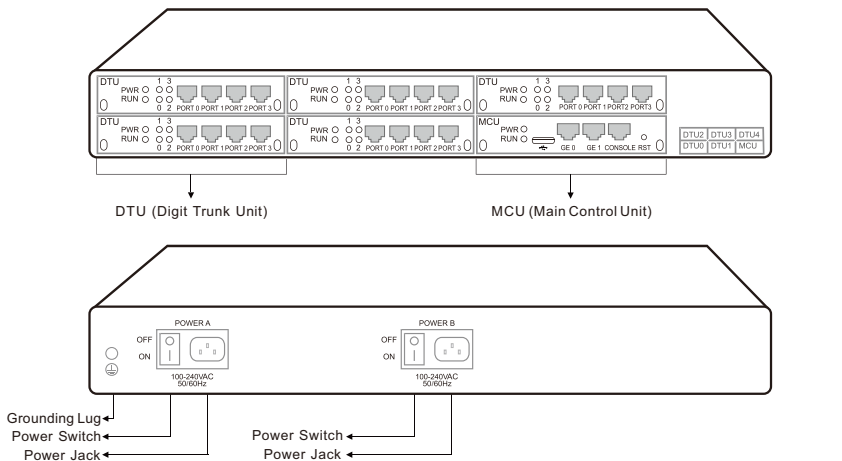

### • DTU(Digit Control Unit)

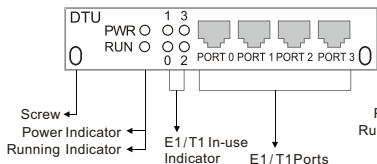

### • MCU(Main Control Unit)

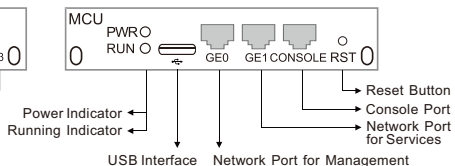

## ▶ MTG2000B

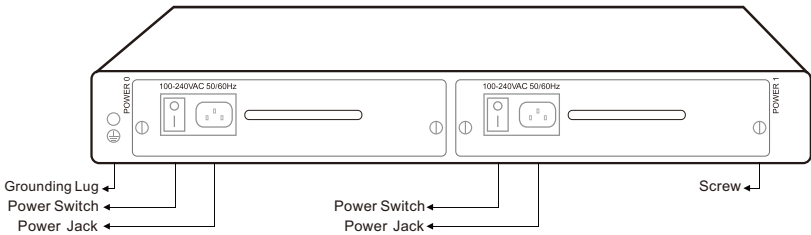
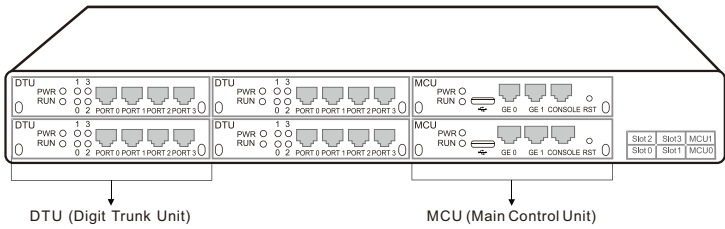

### • DTU(Digit Control Unit)

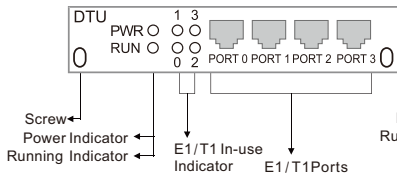

### • MCU(Main Control Unit)

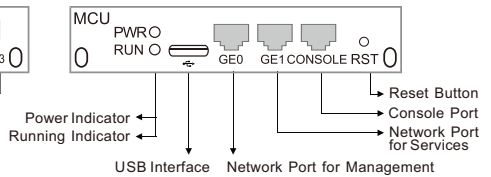

## ▶ MTG3000

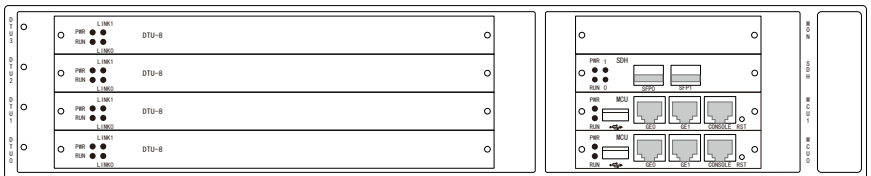

### • DTU

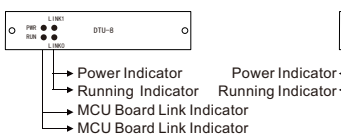

### • SDH

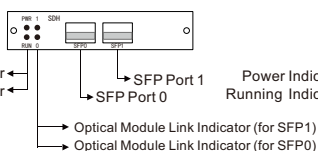

### • MCU

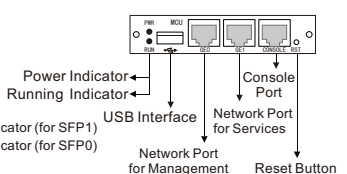

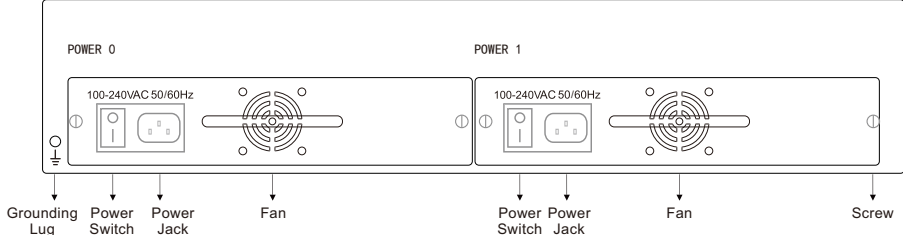

## ▶ MTG5000

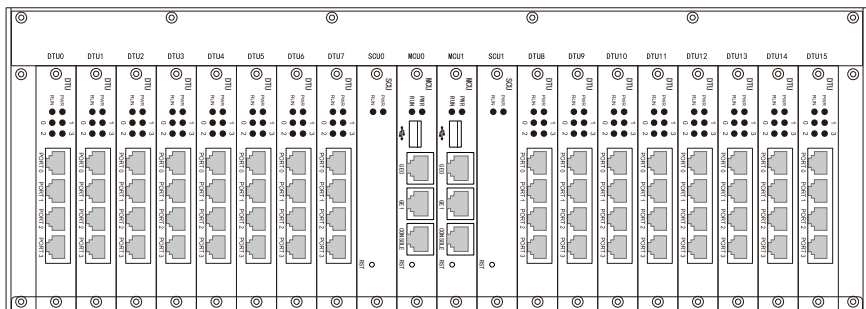

### • DTU

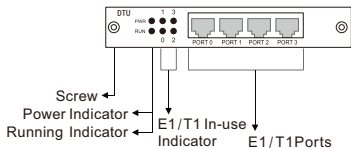

### • MCU

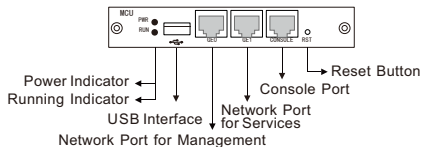

Note: The SCU board implements the communication function between the MCU board and the DTU board, which is not specifically described in this manual.

Grounding Lug

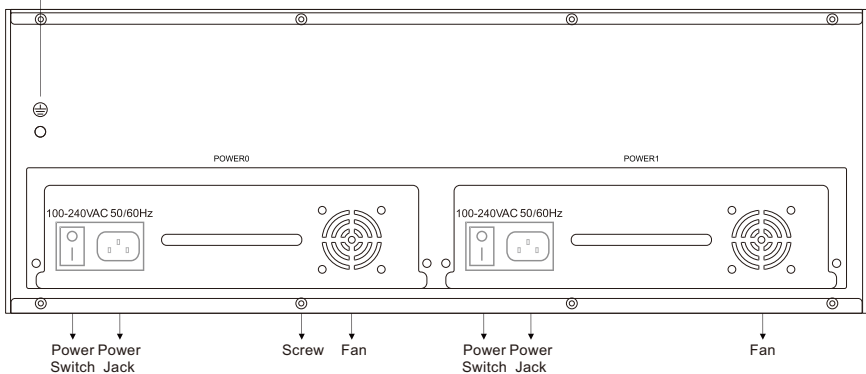

## 4 Installation Instructions

- ◆ Cabinet requirement: ensure the cabinet to accommodate MTG1000 /MTG2000 /MTG2000(B) /MTG3000/MTG5000 is well-ventilated and strong enough to bear the device's weight. It's required that the width of the cabinet be 482.6mm (19 inches)
- ◆ ESD protection: please wear an anti-static wrist strap when installing MTG1000/ MTG2000(B) /MTG3000/MTG5000;
- ◆ Power supply: MTG200 accepts DC 12V power input, while other MTG models accept AC voltage of 100-240V. It's recommended that users use UPS (uninterruptible power system).
- ◆ Device grounding: please ensure the gateway is properly grounded. To avoid interference with the power source, it's recommended that the earth resistance be less than 2 Ω;
- ◆ Temperature and humidity: to avoid any accident that might cause malfunction, it's advised to install the gateway in an equipment room where temperature and humidity are appropriate; the equipment room should be clean and ventilated enough to facilitate heat dissipation;
- ◆ Anti-jamming: to reduce interference, please keep MTG devices away from high-powered transmitters, radar transmitting stations, and large-current devices.

## 5 Installation Instructions

- Connect Gateway with Power Input

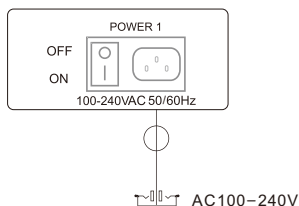

- Connect Gateway with Grounding Lug

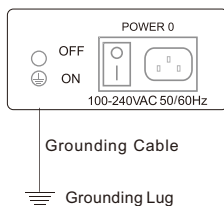

- Connect Gateway with Ethernet

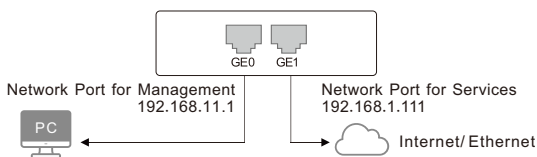

- Connect E1/T1 Port with PSTN/PBX

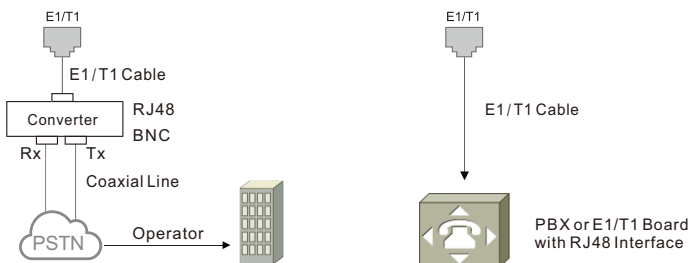

- Connect Gateway with Optical Fibers (Only applicable to MTG3000)

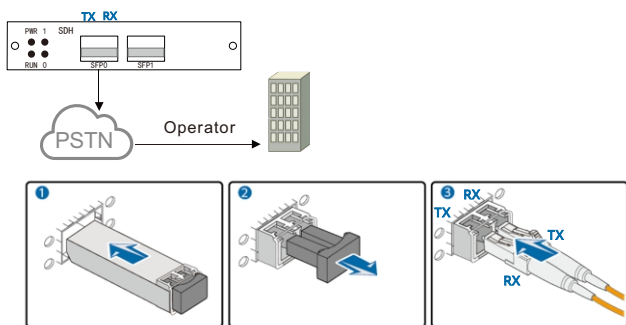

## 6 Wire Sequence of RJ48(E1/T1) Cable

The E1/T1 ports of MTG trunk gateway are connected with RJ48 cables.  
An RJ48 cable has two PINs, and the wire sequence of each PIN is shown as follows:



PIN1: orange & white, orange, green & white, blue, blue & white, green, brown & white, brown.

PIN2: blue, blue & white, green & white, orange & white, orange, green, brown & white, brown.

## 7 Modify PC's IP Address

To log in the Web Management System of the trunk gateway, you need to modify the IP address of PC first to make it at the same network segment with the gateway. Connect PC with the gateway, and then add an IP of 192. 168. 1. XXX or 192. 168. 11. XXX on the PC.

- 1 On the PC, click '**Network (or Ethernet)→Properties**'
- 2 Double-click '**Internet Protocol Version 4 (TCP/IPv4)**'.

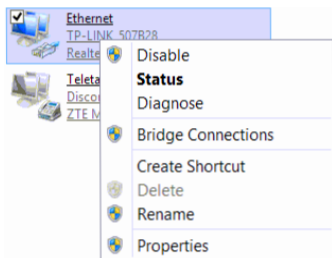

This connection uses the following items:

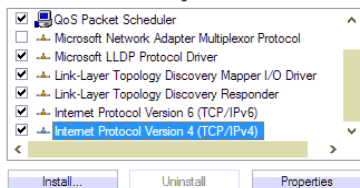

- 3 Select 'Use the following IP address', and then enter an available IP address '192.168.11.XXX' or '192.168.1.XXX'.

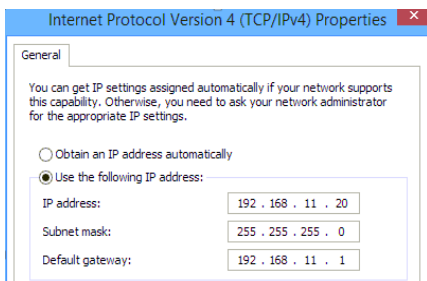

## 8 Log in Web Management System

Open a web browser enter the IP address of the gateway, and then input the IP address of GE0 or GE1 which is connected to the PC. Press Enter, and the login GUI will be displayed.

Model	IP Address of GE0 (Network port for Management)	IP Address of GE1 (Network port for Services)
MTG200	192.168.11.1	192.168.1.111
MTG1000	192.168.11.1	192.168.1.111
MTG2000	192.168.11.1	192.168.1.111
MTG2000B	192.168.11.1	192.168.1.111
MTG3000	192.168.11.1	192.168.1.111
MTG5000	192.168.11.1	192.168.1.111

Enter username and password in the displayed login GUI. The default username is **admin** and the default password is **admin@123#**.

Note: PC and the connected network port must be at the same network segment.

## 9 Modify IP Address of Network Port for Services

After logging in to the trunk gateway, the user needs to modify the IP address of the network port for services. If there's a public static IP address, please configure the IP address of the network port into this static IP address. If the SIP server is connected to a private network, the network port for services should be in the same network segment as the SIP server. After that, please restart the gateway for the configurations to take effect. The network port for management is only used for local management, while the network port for services is used for voice and signaling interactions.

## 10 Configure SDH Parameter

Note: This configuration is only applicable to MTG3000. This configuration step can be ignored if the user purchases a different model.

### (1) Configure SDH Parameter

On the **SDH Config** → **SDH Param** interface, Users can configure the parameters between the device and the optical network terminal.

Line Multiplex (J0 Expectation and J0 Local Value), Higher Order Path (C2, J1 Expectation, and J1 Local Value), and Lower Order Path (V5, J2 Expectation, and J2 Local Value) need to be consistent with the remote configuration, otherwise SDH alarms will occur.

**SDH Param**

Line Multiplex	Local Configuration	Remote Configuration
B1 Bit Error Detection Plan	Bit Statistics	0
B2 Bit Error Detection Plan	Bit Statistics	0
J0 Expectation	MTG3000	MTG3000
J0 Local Value	MTG3000	

**Higher Order Path**

	Local Configuration	Remote Configuration
B3 Bit Error Detection Plan	Bit Statistics	0
C2	(2)TUG structure	(2)TUG structure
J1 Expectation	HuaWei SBS	HuaWei SBS
J1 Local Value	HuaWei SBS	

**Lower Order Path**

	Local Configuration	Remote Configuration
Channel No.	0	
BIP	0	0
V5	(2)Floating asynchronous	(2)Floating asynchronous
J2 Expectation	MTG3000	MTG3000
J2 Local Value	MTG3000	

LPOH Modify

### (2) Check SDH Alarm

On the **SDH Config** → **SDH Alarm** interface, users can check the SDH Alarm. If there are no low-channel alarms and the corresponding E1 ports have no alarms, the services can be activated normally.

#### Multi/High Channel Alarm

Multi Alarm No.	Alarm	Multi Alarm Description	High Alarm No.	Alarm	High Alarm Description
1	■	MS-REI	1	■	HP-REI
2	■	MS-AIS	2	■	HP-RDI
3	■	MS-RDI	3	■	AU-LOP
4	■	R-LOS	4	■	HP-LOM
5	■	R-LOC	5	■	HP-TIM
6	■	R-LOF	6	■	HP-SLM
7	■	R-OOF			
8	■	RS-TIM			

## Low Channel Status and Alarm

Low Channel Status																
Channel No.	0	1	2	3	4	5	6	7	8	9	10	11	12	13	14	15
Port 0	■	■	■	■	■	■	■	■	■	■	■	■	■	■	■	■
Port 16	■	■	■	■	■	■	■	■	■	■	■	■	■	■	■	■
Port 32	■	■	■	■	■	■	■	■	■	■	■	■	■	■	■	■
Port 48	■	■	■	■	■	■	■	■	■	■	■	■	■	■	■	■

Please input channel no. to display:

Low Channel Alarm		
Alarm No.	Alarm	Low Channel Alarm Description
1	■	LP-REI
2	■	LP-RFI
3	■	LP-RDI
4	■	TU-LOP
5	■	LP-TIM
6	■	LP-SLM

### (3) Configure Channel Map

On the **SDH Config** → **Channel Map** interface, users can configure the mapping scheme. The mapping carried out on MTG3000 must be the same as that on the optical transceiver.

Sdh Channel Mapping																
Port No.	0	1	2	3	4	5	6	7	8	9	10	11	12	13	14	15
Channel No.	0	21	42	1	22	43	2	23	44	3	24	45	4	25	46	5

Port No.	16	17	18	19	20	21	22	23	24	25	26	27	28	29	30	31
Channel No.	26	47	6	27	48	7	28	49	8	29	50	9	30	51	10	31

Port No.	32	33	34	35	36	37	38	39	40	41	42	43	44	45	46	47
Channel No.	52	11	32	53	12	33	54	13	34	55	14	35	56	15	36	57

Port No.	48	49	50	51	52	53	54	55	56	57	58	59	60	61	62	
Channel No.	16	37	58	17	38	59	18	39	60	19	40	61	20	41	62	

Mapping Scheme:  ITU-T  Chinese Standard  User-Defined  Sdh Loop SlotIn  Sdh Loop SlotOut

## 11 Configure PRI/SS7 Trunk

### (1) Configure PRI Trunk

On the **PRI Config** → **PRI Trunk** interface, add a PRI trunk. 'Channel ID' of the PRI trunk should be the same with that of the peer switch.

As for the 'Switch Side' parameter, if the peer switch is configured as 'User Side', the PRI trunk should be configured as 'Network Side'; if the peer switch is configured as 'Network Side', the PRI trunk should be configured as 'User Side'.

PRI Trunk Add	
Trunk No.	<input type="text" value="2"/>
Trunk Name	<input type="text" value="REPBX"/>
Channel ID	<input type="text" value="0"/>
D-Channel	<input type="text" value="Enable"/>
E1/T1 Port No.	<input type="text" value="2"/>
Protocol	<input type="text" value="ISDN"/>
Switch Side	<input type="text" value="User Side"/>
Alerting Indication	<input type="text" value="ALERTING"/>

## (2) Configure SS7 Trunk

- ① On the **SS7 Config** → **SS7 Trunk** interface, add an SS7 trunk.

Please consult local service provider about the information of Protocol Type (TUP/ISUP), OPC and DPC.

SS7 MTP Link Add	
No.	3
Trunk No.	3 <TELE>
Link No.	0
Signaling Link Code	0
E1/T1 Port No.	3
Channel No.	16
Caller Type	Subscriber
Callee Type	Not Configured
OrgCallee Type	Not Configured
Numbering Plan	ISDN
Calling Presentation	Allowed
Screening Indicator	User Provided
Called Stop sending	Disable
Calling Stop sending	Disable
Link Mode	Default
Binding Slave TG	None

- ② On the **SS7 Config** → **SS7 MTP Link** interface, add an SS7 signaling link for the trunk. Please consult local service provider about 'E1/T1 Port No.', 'Channel No.' of the SS7 signaling link, as well as 'Caller Type'.

SS7 MTP Link Add	
No.	3
Trunk No.	3 <TELE>
Link No.	0
Signaling Link Code	0
E1/T1 Port No.	3
Channel No.	16
Caller Type	Subscriber
Callee Type	Not Configured
OrgCallee Type	Not Configured
Numbering Plan	ISDN
Calling Presentation	Allowed
Screening Indicator	User Provided
Called Stop sending	Disable
Calling Stop sending	Disable
Link Mode	Default
Binding Slave TG	None

- ③ On the **SS7 Config** → **SS7 CIC** interface, add an SS7 circuit for the SS7 trunk. Generally, an E1 port contains 32 channels, while a T1 port has 24 channels. Please consult local service provider about the 'Start CIC No.'.

SS7 Circuit Add	
Trunk No.	3 <TELE>
Start E1/T1 port No.	3
End E1/T1 port No.	3
Start Channel	0
Start CIC No.	0
Count	32

## (3) Configure E1/T1 Frame Mode

On the **PSTN Group Config** -> **E1/T1 Parameter** interface, modify the frame mode of the E1/T1 port to make it the same as that of the peer device.

E1/T1 Parameter Modify	
Start E1/T1	Port 0
End E1/T1	Port 0
Work Mode	E1
PCM Mode	A LAW
Frame Format	DF
Line Code	HDB3
Line Built Out	Short Haul(-10 DB)

## 12 Configure SIP Trunk

On the **SIP Config** → **SIP Trunk** interface, user needs to fill in the IP address of the peer device (remote address) and remote port. Other parameters can be retained as default settings.

SIP Trunk Add	
Trunk No.	2
BI	GE1
Trunk Name	IPPBX
Remote Address	10.10.0.50
Protocol Type	UDP
Remote Port(UDP)	5060
Remote Port(TCP/TLS)	5060
Outbound Proxy	
Outbound Proxy Protocol Type	UDP
Outbound Proxy Port(UDP)	5060
Outbound Proxy Port(TCP/TLS)	5060
From Header	Local Domain
PPID	Disable
Local Domain	Disable
Support SIP-T	Disable
Get Callee from	Request-line
Get Caller from	User Name
Register to Remote	No
Incoming SIP Authentication Type	IP Address
Rport	Disable
Dynamic Nat	Disable
Static Nat	Disable
Outgoing Calls Restriction	No
Incoming Calls Restriction	No
Incoming Time Restriction	Disable
Heartbeat Bound	Disable
Detect Trunk Status	No
Heartbeat Username	heartbeat
Enable SIP Trunk	Yes

## 13 Configure Inbound & Outbound Routes

### (1) Configure Inbound Route

On the **Call Routing** → **PSTN** → **IP Routing** interface, add an inbound route. Select a source trunk and a destination trunk that have been created. If '.' is filled in for Caller Prefix and Callee Prefix, it means any number can be the caller number and callee number of this inbound route.

Route PSTN->IP Add	
Index	510
Description	incoming call
Source Type	Trunk
PSTN Trunk	2 <REPBX>
Callee Prefix	.
Caller Prefix	.
Destination Type	Trunk
Trunk Type	SIP
IP Trunk No.	2 <IPPBX>
Number Filter Profile ID	255 <None>

## (2) Configure Outbound Route

On the **Call Routing -> IP>PSTN Routing** interface, add an outbound route. Select a source trunk and a destination trunk that have been created. If '.' is filled in for Caller Prefix and Callee Prefix, it means any number can be the caller number and callee number of this outbound route.

IP->PSTN Routing Add	
Index	510
Description	outgoing call
Source Type	Trunk
Trunk Type	SIP
IP Trunk No.	2 <IPPBX>
Callee Prefix	.
Caller Prefix	.
Destination Type	Trunk
PSTN Trunk	2 <REPBX>
Filter Profile ID	255 <None>

## 14 More Details

This document only provides instructions for quick installation and basic configuration, For detailed configuration and parameter explanation, please refer to user manual or ask for online technical support.

## 15 Trouble Shooting

- What if E1/T1 indicator is still dull after the corresponding E1/T1 port has been connected to an E1/T1 cable?
  - In case that the E1/T1 port is directly connected to a peer device with a standard RJ48C E1/T1 cable, please check whether the peer device is equipped with standard RJ48C interface first, and then check whether the wire sequence of E1/T1 cable is correct or not.
  - In case that the E1/T1 port is connected to a switch with E1/T1 cable and coaxial line, please check whether the connector of BNC transit box works well or not, and then check whether the RX end and TX end are connected properly.
  - Exchange the E1/T1 cable with another one that works normally, so as to confirm whether the E1/T1 port malfunctions.
- What if E1/T1 indicator flashes after the corresponding E1/T1 port has been connected to an E1/T1 cable?

Log into the web management system to modify the frame mode of the E1/T1 port. If the E1/T1 indicator still flashes, it means there are error codes in the physical link. Please contact service provider to check this problem.
- Forget the IP address of the trunk gateway.

Connect the trunk gateway's console port to a PC via an RS232 serial cable. After the command interface is displayed, input 'show int' under the 'ROS#' mode to query the current IP address of the gateway.
- Forget username and password.

Connect the trunk gateway's console port to a PC via an RS232 serial cable, and then ask for online technical support.

IP COMMUNICATION SOLUTIONS

Shenzhen Dinstar Co., Ltd.  
Web: www.dinstar.com

